

Józef Kuczmaszewski

Fundamentals of metal-metal adhesive joint design

Lublin University of Technology
Polish Academy of Sciences, Lublin Branch
Lublin, 2006

Reviewer:

prof. dr hab. inż. Robert Sikora

Translated by:

Tomasz Bylica

Cover designed by:

Radosław Dolecki

© Politechnika Lubelska

ISBN 83-89293-11-0

Printed by:
WSCHÓD Agencja Usługowa
LUBLIN, ul. Długa 5
www.wschod.lublin.pl

List of contents

1. Theoretical foundations of adhesion	9
1.1. Basic terms	9
1.2. Adhesion in engineering	10
1.3. Major theories of adhesion	11
1.4. Adhesion in molecular-kinetic approach	27
1.5. Adhesion in thermodynamic approach	28
References	35
2. Adhesives	39
2.1. General characteristics	39
2.2. Classification of adhesives	42
2.3. Applications of adhesives	46
2.4. Sealants and renovation putties	47
2.5. Adhesive components and modification	49
2.6. Special adhesives	51
2.7. Conclusions	54
References	55
3. Bonding operations	57
3.1. Typical bonding operations.....	57
3.1.1. Preparation of bonded surfaces	58
3.1.2. Choice of adhesive	79
3.1.3. Preparation of adhesives	80
3.1.4. Application of adhesive	83
3.1.5. Curing of adhesive	84
3.1.6. Setting (fixing) of bonded elements	85
3.1.7. Finishing and bond inspection	86
3.2. Principles of selection of technological parameters of bonding	87
References	88
4. Producibility of bonded structures	91
4.1. Factors determining producibility in bonding operations	91
4.2. Examples of typical assembly operations	100
4.3. Conclusions	104
References	105
5. Strength of bonded joints	107
5.1. Stress analysis in bonded joints	107
5.1.1. Effect of edge line length	114
5.1.2. Effect of chamfering of overlap ends	115
5.1.3. Effect of adhesive flash at overlap ends	118
5.2. Strength of face-face bonds	119
5.3. Strength of trunnion-sleeve bonds	122
5.4. Tear-off strength	123
5.5. Compound cases of bonded joint loading	125

5.5.1 Resistance to cracking	125
5.5.2. Thermal shock fatigue	137
5.5.3 Eccentricity of load	139
5.6. Creep in bonded joints	140
5.7. Fatigue strength of bonded joints	146
5.8. Ageing of adhesive materials	147
References	159
6. Special tooling for bonding operations	163
6.1. Typical procedures in bonding operations	163
6.2. Dosage and mixing equipment	163
6.3. Adhesive applicators	165
6.4. Fixtures and alignment tools	169
6.5. Equipment for application of clamping pressure	171
6.6. Heating equipment	174
6.7. Important tips for engineers designing bonding fixtures	175
References	176
7. Design of bonded joint structures	177
7.1. Input data for bonded joint design	177
7.2. Analysis of stress status	179
7.3. Heuristic model for strength estimation of bonded metal-metal joints	180
7.4. Safety assessment of bonded structures	186
7.5. Determination of dimensions of overlap bond	191
References	192
8. Quality inspection/testing of bonded joints	193
8.1. Testing of adhesives	193
8.2. Testing of adhesive properties of surface layer of bonded elements	194
8.3. Non-destructive testing of bonded joints	197
8.4. Destructive testing of bonded joints	201
References	204
9. Conclusion	207

List of symbols used

E_m – coefficient of elongation elasticity of bonded material
 E_k – coefficient of elongation elasticity of adhesive when cured
 G_k – coefficient of shape elasticity of adhesive
 ν_k – Poisson coefficient of adhesive
 ν_m – Poisson coefficient of bonded material
 θ – wetting angle
 R_r – tensile strength of bonded materials
 γ_1 – free surface energy of adhesive
 γ_s – free surface energy of bonded material
 η – viscosity
 H – hardness
 σ_w – internal stresses
 t – time
 R – radius
 p – pressure
 K – Boltzmann constant
 T – temperature
 P – force
 S – surface area
 W_{ad} – work of adhesion
 V – volume
PAC – Poliaminoamid C hardener
E57 – Epidian 57 epoxy adhesive
 τ_n – crippling shear stress
 g_m – thickness of bonded element
 g_k – thickness of adhesive layer
 l_z – overlap length
 l_{gr} – limit overlap length
 k_r – permissible tensile stress
 b – overlap width
 M_g – bending moment
 J – integral J
 r – distance between charges
 G – coefficient of shape elasticity of bonded material
 W_k – work of cohesion
Z-1 – triethylenetetramine hardener
 σ_m – tensile breaking stress
 R_a – mean arithmetic deviation of profile from median line

Chapter 1

Theoretical foundations of adhesion

1.1. Basic terms

Etymologically, the term „adhesion” is derived from the Latin word „adhaesio” i.e. tacking or joining. In this context **adhesion** should be treated as a surface phenomenon that leads to the formation of a new system – an adhesive bond with a complex of specific characteristics determined by the properties of the adhesive and of the materials bonded, and by the occurrence of a division between them [1.6, 1.20].

Cohesion means the inner coherence that a material, the adhesive in the case under consideration, achieves as a result of a variety of physicochemical processes taking place in the course of curing.

Adhesive is an organic or inorganic substance that is capable of permanent joining of materials as a result of various physical or physicochemical phenomena occurring at the adhesive-bonded material phase boundary (adhesion) or within the adhesive mass (cohesion). Adhesives can be single- or multi-component preparations. The composition of the adhesive mass, apart from the basic component, may include curing agents or hardeners (for chemically cured adhesives), solvents and thinners, thixotroping agents, dyes, antioxidants, fillers, antistatic agents, softeners, stabilising agents, and others.

Curing agents or hardeners are substances which, added to a polymer, enter in a chemical reaction with it to ultimately impart to the substance the state of a solid.

Solvents are fluids capable of dissolving other substances, i.e. of forming with those substances a homogeneous system or mixture.

Thinners are fluids thinning down the concentration of a substance solution, without having capacity to dissolve.

Stabilising agents are compounds that slow down reactions taking place in the processes of ageing of materials, especially of polymers. This concerns primarily the processes of degradation or destruction occurring under the effect of heating, shearing, radiation, or influenced by moisture, fungi [1.16] etc.

Plastifiers or softening agents are liquid or solid chemically inert organic substances that interact physically with polymers to reduce intermolecular forces, which leads in consequence to lowering of the brittle point and glass temperature of polymers, of the softening point, hardness and tensile strength, with simultaneous increase of elasticity [31].

Fillers and carriers are auxiliary agents whose function is to modify the properties of the polymer. They are materials of natural or synthetic origin, introduced into the polymer as a matrix and forming with it a suitable composite material with properties altered in the desired direction.

Antistatic agents are good electrical conductors that are used to reduce or eliminate electrostatic charges on the products. Their action consists in reducing the number of electrostatic charges on material surfaces.

Thixotroping agents are substances introduced to polymers in order to impart to them thixotropic properties. Their effect consists in that adhesives in repose are characterised by greater viscosity than during mixing or shaking. [1.16]

Separators (anti-adhesive agents) are substances that, introduced into the mass of a polymer or onto its surface, prevent the adhesion of the material to moulds and other equipment; in many cases they also prevent corrosion processes.

Antipyrenes are substances reducing combustibility; they are capable of effecting spontaneous extinguishing through the emission of large amounts of non-flammable gases.

Adhesion is usually considered in two fundamental systems: **solid-liquid**, i.e. a system leading in consequence to the formation of an **adhesive joint**, that is an area of joining of two materials, and **solid-liquid-solid**, i.e. a system leading to the formation of an **adhesive bond**, i.e. a connection made up of two joints, where the layer of adhesive material acts as the link.

Classic adhesive joints are formed between solid substrates and paints, enamels, printing inks, metallic plastic coatings, plastic coats on metal surfaces, etc. Typical adhesive bonds are connections based on glues, putties, laminated composite materials, sandwich structures, layered composites, etc.

1.2. Adhesion in engineering

Adhesion is a phenomenon whose importance in numerous processes is dominant or significant. Special importance characterizes such adhesive bonds in which adhesion plays a dominant role in the constitution of their properties [1.3, 1.22]. This concerns especially such technologies as structural bonding, sealing, and cementing. Such bonds are used more and more frequently as substitute for welding, spot welding, soldering, or forced-in joints [1.10, 1.18, 1.27].

Adhesive bonding as a method of joining has a very long history and dates back to ancient times. Glues of animal origin, especially bone, hide and casein glues, were used to bond papyrus, among other things. Also common were masonry mortars which in essence were glues.

Adhesion concerns also numerous technologies related to surface engineering, such as paint and enamel coating, or application of coats with special properties. Moreover, adhesion as a phenomenon plays an important role in such technologies as bimetal production, powder metallurgy, flotation processes, production of laminated composites, and many others. Adhesion is also highly important in the interpretation of numerous processes in engineering. This concerns in particular the techniques and processes of diagnostics as well as the processes of friction and wear [1.1, 1.7, 1.14, 1.25].

The technological processes under analysis mostly require „high” adhesion, while in the design of kinematic sets of drive units we are interested in such a selection of materials and such a constitution of their properties as to obtain as low levels of adhesive bond forces as possible. What is required, therefore, is adequate knowledge on the possibility of control of adhesive properties of surface layers of structural materials. This problem will be presented in greater detail in subsequent chapters.

1.3. Major theories of adhesion

The literature of the subject, often even highly specialized, contains frequent inconsistency in the terminology used. The term “adhesion” is sometimes taken to mean energy and sometimes strength, and “force of adhesion” can also be encountered.

At present adhesive forces and bonds are classified as shown in Fig. 1.1 below.

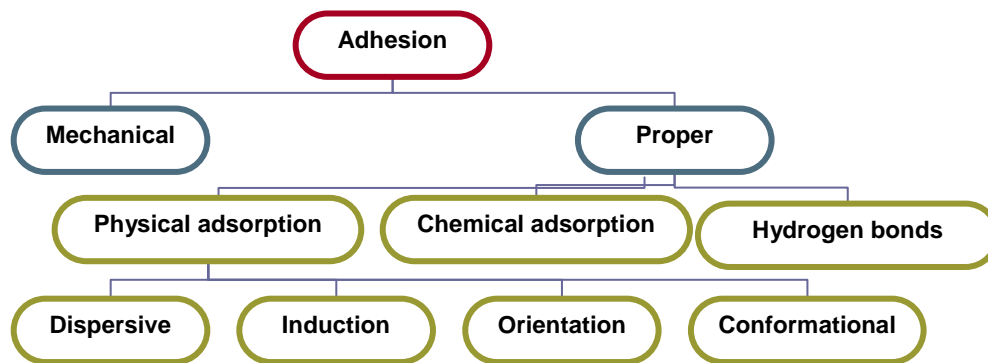

Fig. 1.1. Classification of adhesive forces and bonds [1.20]

Historically speaking, the first theoretical works on adhesion appeared in the nineteen twenties. One of the first hypotheses [1.6] assumes that the condition for the formation of an adhesive bond is the penetration of the adhesive into the micropores of the bonded elements and creation of mechanical links capable of transmitting loads. The idea of mechanical adhesion is presented schematically in Fig. 1.2.

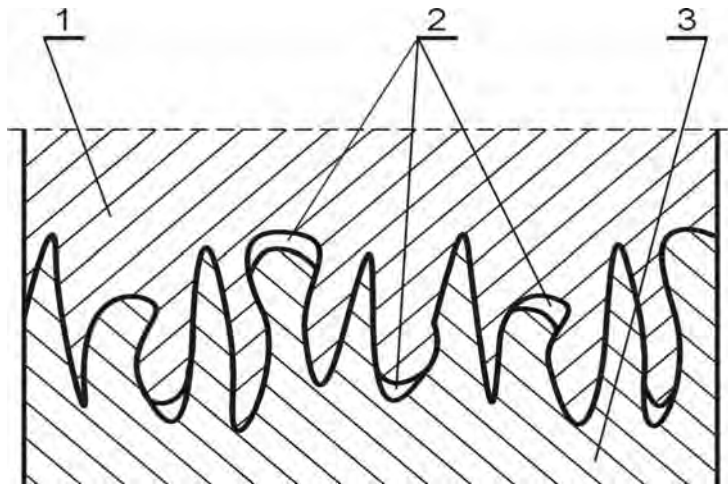

Fig. 1.2. Mechanical adhesion – schematic presentation: 1 – adhesive, 2 – entrapped air, 3 – bonded material

Views on the importance of mechanical adhesion changed [1.6, 1.33, 1.36], as new theories were developed. For a period of time its importance was assumed to be negligible, but now it is accepted that in certain operations mechanical adhesion plays a significant role. The value of mechanical adhesion is constituted primarily by the topography of surface. The stereometric parameters of the surface layer play a significant role in the process of adhesive joining of elements. This follows not only from the fact of increase of the actual surface area through its mechanical „development”, but also results from changes in the degree of imbalance of intermolecular forces in the outer nanolayer of atoms and molecules, as shown schematically in Fig. 1.3.

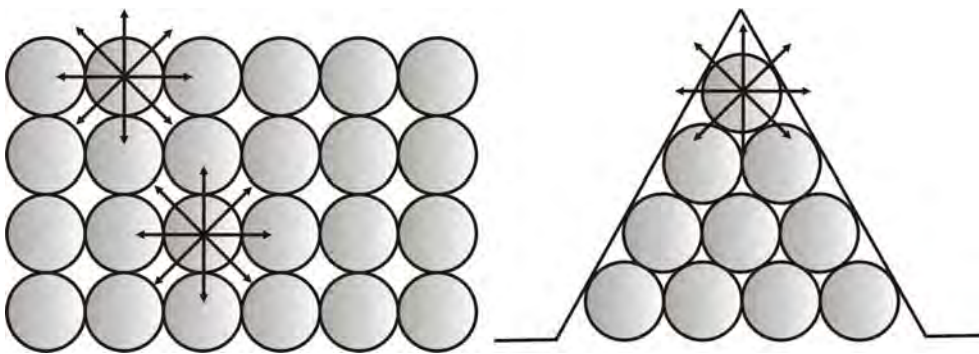

Fig. 1.3. Schematic illustration of the relation between the value of free surface energy and the stereometric features of the bonded elements [1.12]

Parameter R_a , commonly used in engineering for the estimation of surface roughness, does not, however, describe well the stereometric features of the surface from the viewpoint of adhesive properties. At present there are possibilities of more objective estimation of the stereometric features of the surface, employing spatial parameters for its description.

It is, however, necessary to point out that excessive „development” of the surface may lead to a weakening of the joint as a whole. Fig. 1.4 presents schematically the surface layer of an aluminium alloy after the operation of etching.

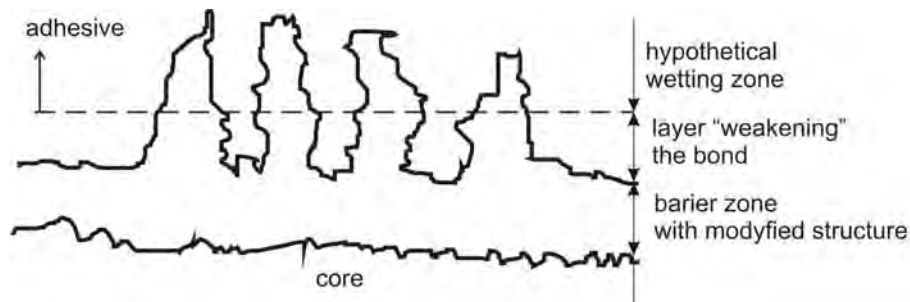

Fig. 1.4. Schematic presentation of the surface layer of an aluminium alloy after the operation of etching

A surface layer formed as shown in Fig. 1.4 results from incomplete wetting and the formation of a “weakening” transition zone in an adhesive bond. Therefore, in such cases correct pressure in the course of bonding is important. The energy properties of thus prepared surface layer depend on the process parameters, not only of the etching operation but also of auxiliary operations, such as rinsing or drying. Rinsing may lead to closing of pores, and to the formation of hydrates (bayerite, boehmite) significantly changing the spatial parameters of the surface layer, and thus its energy properties. From among the spatial parameters especially important are the longitudinal and lateral spacing of irregularities and the apex angle of irregularities.

The concept of free surface energy refers to the surface, but in reality its summary value is constituted by several atom layers, as illustrated schematically in Fig. 1.5.

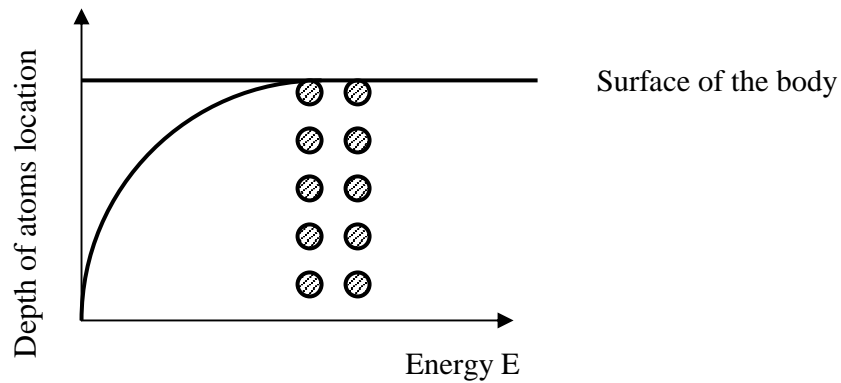

Fig.1.5. Share of surface zone energy in total surface energy [1.12]

In view of the fact that the value of free surface energy relates to several layers of atoms, in the engineering sense we may therefore speak of the energy of the surface layer. A schematic presentation of the zones of effect of free surface energy and inner energy is given in Fig. 1.6.

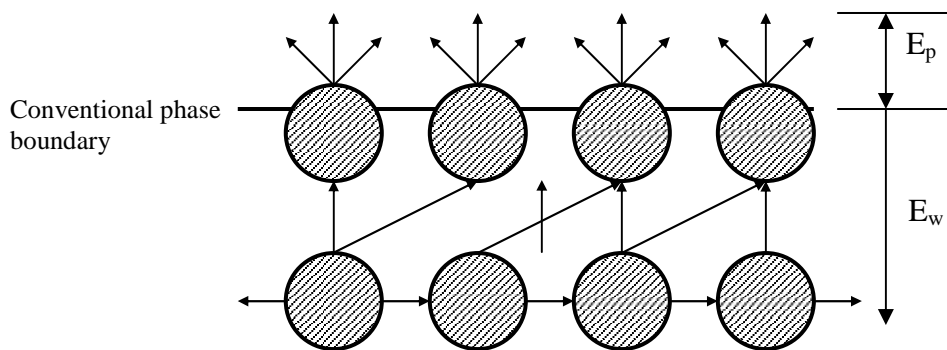

Fig.1.6. Schematic presentation of zones of effect of free surface energy (E_p) and inner energy (E_w) [1.12]

Parameters defining the stereometric features of surface determine the area of the wetting surface, i.e. of the active surface [1.28, 1.29]. If we assume that the nominal surface area S_n is defined macroscopically by the geometric dimensions of the bond, the true surface area S_{rz} includes the stereometric „development” of the nominal surface, and the active surface is the wetting surface S_{zw} , their mutual relative ranking in terms of size can be presented as follows:

$$S_n < S_{zw} < S_{rz}$$

From the practical point of view it is important to determine the active surface. This can be done from the relation:

$$S_{zw} = \iint_S F(x, y) dx dy \quad (1.1)$$

where $F(x, y)$ is a function describing the active surface, $S = \{(x, y) \in R^2 : \phi(x, y)\}$ is the nominal surface area. The value of the active surface area, apart from the stereometric features of the surface, is also affected by the rheological properties of the adhesive, pressure, and by the set of physicochemical properties of the materials bonded.

Penetration of the adhesive into the micro-pores of the surfaces joined depends on a number of factors, and mainly on viscosity, pressure, temperature, time of contact, and also on the stereometric features of cavities. This is described, among others, by the Washburn equation [1.28] in the form:

$$h = \left(\frac{rt\gamma_L \cos \theta}{2\eta} \right)^{0,5} \quad (1.2)$$

where: h – depth of adhesive penetration into micro-irregularities of surface treated as capillaries with radius r , t – time of penetration, γ_L – free surface energy of the adhesive, η – viscosity of the adhesive, θ – wetting angle.

This relation can be used directly to derive the relation between the wetting angle and the time of contact of the liquid with the surface of the material. This is important, considering that the wetting angle is treated as a practical measure of the adhesive properties of materials.

These features affect the energy of spread, i.e. the difference between work of adhesion and work of cohesion. Leaving out from the considerations the possibility of constituting the work of cohesion at the moment of wetting (e.g. through the use of thinners), the energy of spread depends directly on the value of free surface energy. Including in the considerations the possibility of constituting its value the relation for the value of the active surface area can be presented in the following form [1.20]:

$$S_{zw} = S_{rz} f \left(\frac{1}{\eta}, p, R_r, \sigma_w, H, t, E_r, m_i \right) \quad (1.3)$$

where: η – viscosity of the binding agent, p – pressure during the process of curing, R_r – tensile strength of bonded materials, σ_w – natural stresses, H – hardness, t – time, E_r – coefficient of longitudinal elasticity of bonded materials, m_i – vector

of dimensionless coefficients defining the relation of stereometric features of surface layer to factors affecting the active surface.

Analysis of the function (1.3) indicates the following major determinations:

- the most favourable is the topography of a surface with developed structure, and thus possibly large true surface area; there is, however, a certain limit – too long and narrow irregularities may lead to considerable weakening of the surface layer and, consequently, to a lowering of the strength of the bond as a whole;
- active surface area increases with decreasing viscosity of the binding agent, and the viscosity of the adhesive is strongly dependent on temperature and time;
- pressure is an important technological factor; generally, increase in pressure facilitates wetting, but excessive pressure causes numerous punctures of the binding medium, plastic deformations of surface irregularities, and - as a consequence – a decrease of adhesive strength;
- increase of natural stresses in the surface layer causes an increase in free surface energy, and thus is favourable from the viewpoint of the wetting process, provided that the operations as a result of which the increase in natural stresses occurred do not cause significant deterioration in other physical or stereological properties of the surface layer that would affect its adhesive properties;
- increase in surface layer stiffness and hardness of the bonded materials is favourable for the wetting process; this results both from the effect of those factors on the value on free surface energy and from the increase in the compressive strength of surface micro-irregularities.

In the physicochemical aspect, the wetting process is very complex and depends also on chemical changes in the surface layer, constituted in treatment processes, related to the environment in which the bond is effected, and other factors in the system, not necessarily observable; the effect may be momentary as well long-lasting.

Adhesion proper, also referred to as specific, incorporates the forces of physical adsorption, chemisorption, as well as hydrogen bonds. The theory of mechanical adhesion has been complemented successively with other theories as successive experiments and analyses showed that the forces of adhesion are not determined solely by forces originating from mechanical anchorage points. An adsorption theory of adhesion was presented, based on the assumption that adsorption and adhesion are based on the difference between the energy status of molecules on the surface or liquids or solids and of molecules in deeper layers of those phases. It has also been repeatedly shown that chemisorption plays an important role in the theory of adhesion. It assumes the occurrence of chemical adsorption between the adhesive and the substrate, thanks to function groups

capable of creating chemical bonds. We know also that hydrogen bonds are important in processes of adhesion.

In Poland the subject-matter of adhesion, and especially that of adhesive bonding in its theoretical and applied aspects, was taken up in the nineteen fifties, but particularly notable advances in that interdisciplinary field of knowledge have been recorded during the last three decades. Notable monographs on the subject include such works as those by J. Godzimirski, B. Jurkowski, R. Sikora, Z. Zaczek, M. Żenkiewicz, and their collaborators [1.2, 1.8, 1.11, 1.13, 1.28, 1.34, 1.35].

Adsorption on the solid-liquid boundary occurs with relation to the number of components of liquids that are considered to be solutions and to their character (electrolytic or non-electrolytic). Adsorption from solutions is affected by the structure of adsorbents which depends on the degree of their porosity and on the possibility of adsorbate penetration into the porous structure of the adsorbents. Adsorbents with narrow pores have stronger adsorptive properties. During adsorption of simple organic substances at room temperature both physical and chemical adsorption is possible. The rate of the process of adsorption from solutions depends primarily on the size and structure of adsorbed molecules, on the type of solvent, and on the porosity of the adsorbent. Every process of adsorption depends at the initial stage on the transport of adsorbate to the surface of the adsorbent; in the second stage the process of adsorption takes place on the surface of the adsorbent. In the initial stage the laws of diffusion are decisive. In that stage we should distinguish diffusion of adsorbate to the „outer” surface of the adsorbent and diffusion of adsorbate into the adsorbent capillaries. The process of adsorption is so rapid that it is difficult to determine its course. Experimental data indicate that in processes from gaseous phase and from solutions most of the adsorbed substance is transferred to the surface layer of the adsorbent in a relatively short time, but it takes very long for adsorption balance to be achieved.

The character of adsorption forces is different in physical than in chemical adsorption. In the case of chemical adsorption the adsorbed molecules and the adsorbent form a uniform system, as opposed to physical adsorption where adsorbate molecules and the adsorbent can be considered as two independent systems [1.9].

Chemical adsorption is usually activated adsorption. The occurrence of activation energy is not a principal criterion of chemical adsorption, but on the other hand the lack of activation energy is not an absolute feature of physical adsorption. Activated adsorption differs from non-activated adsorption in the character of the kinematics of the process. Non-activated adsorption is a rapid process, while the rate of activated adsorption can be measured and increases with increasing temperature. In the case of chemical adsorption, molecules get dissociated on the surface and their component atoms get bonded individually, through chemical bond forces, with the surface.

The mutual interaction between such a molecule and the surface is presented in Fig. 1.7. The origin of the axis of ordinates corresponds to a state of equilibrium between the forces of attraction and repulsion of particles.

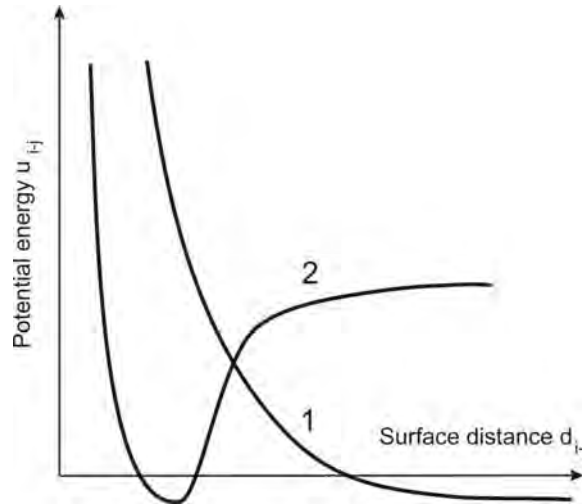

Fig.1.7. Potential energy $u_{i,j}$ of adsorbed molecule and of an atom (surface molecule) versus distance d : 1 – curve of physical adsorption, 2 – curve of chemical adsorption [1.9]

Summing up the adhesive forces of all the bonds cannot be used as a basis for calculating strength, as on the surface there occur differences of chemical and structural nature, as well as micro-deficiencies. This is an important conclusion; the molecular-kinetic theories developed are primarily of a theoretical significance. Under actual conditions, an adhesive bond is a heterogeneous and complex system; the structure of such a system is presented schematically in Fig. 1.8.

The surface layers of solids are in a state of stress. This is caused by the shift of ions from the potential trough and leads to the occurrence of excess potential energy compared to the energy of an atom inside a body. The potential energy of a body is made up of the network energy and additionally of the excess energy of the surface layers [1.15, 1.17].

That excess of energy referenced to a unit of surface area is the surface energy. The excess energy of surface layers is described by the relation:

$$E_s = \iint_D G_s(x, y) dA \quad (1.4)$$

where:

E_s – excess energy of surface layer, G_s – surface energy (per unit of surface area),
 A - surface, D – area of integration.

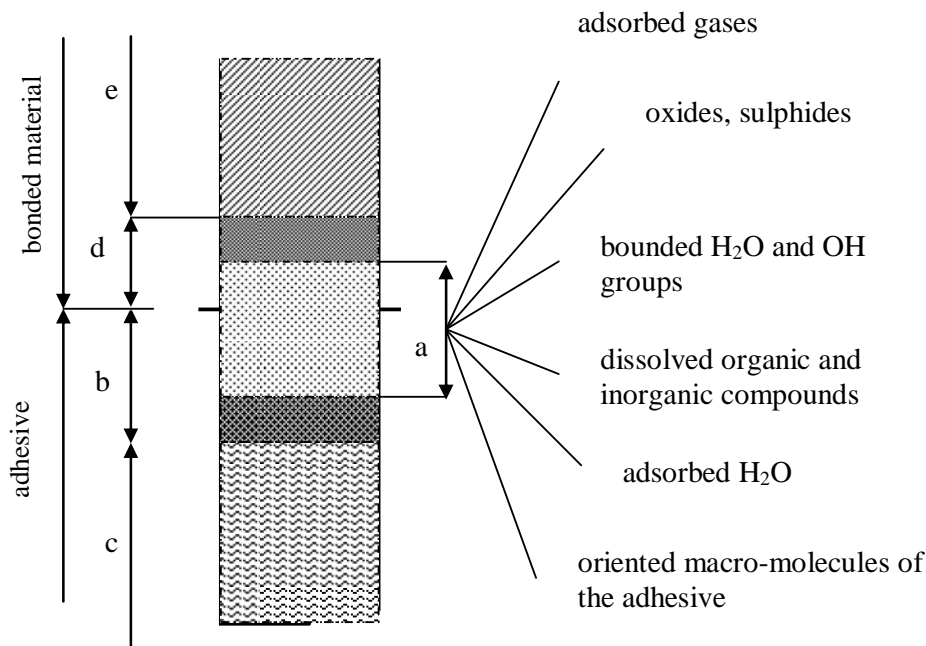

Fig. 1.8. Schematic model of adhesive bond: a – transitory zone, b- surface layer of plastic material, c – core of plastic material, d – surface layer of metal, e – core of metal [1.20]

Surface energy can be treated as non-saturation of bonds of atoms located on the surface. Such an approach to energy suggests at the same time that it belongs to the structure of metal and determines the value of energy that can be attributed to the individual crystallographic planes. A characteristic feature of crystalline bodies is anisotropy of their properties, including anisotropy of surface energy.

Dense-packed plane is characterized by the lowest relative surface energy. This can be explained by the distribution of electron density on metal surface. For a densely packed surface no sharp periodic changes are observed in the distribution of positive and negative charges. From the electron point of view, a dense-packed surface is a relatively smooth surface. In the case of a plane in periodically alternating electron distribution, metal surface has the configuration of alternating hills and valleys. Positively charged electron cores are located slightly above the surface, with negatively charged electrons being located slightly below [1.9, 1.35].

Therefore, a dense-packed surface is characterized by low surface energy, and a more „open” plane has a higher surface energy and is more reactive when in

contact with a different phase. A change in electron density on the surface of a metallic body is conducive to changes in reactivity.

In the inter-phase area there occurs a sudden change in the physical or chemical properties of each of mutually adherent bodies. It is estimated that the inter-phase area has the dimensions of approximately 1 nm (10^{-9} m). The size of the area is significantly related to – among other things – miscibility.

An extremely important role in the mechanism of adhesive joining is that of van der Waals forces, i.e. forces included in physical adsorption. Van der Waals formulated the equation of the state of actual gas [1.9]:

$$\left(p_z + \frac{a}{V^2}\right)(V - b) = RT \quad (1.5)$$

where: p_z – external pressure, a – constant characterizing forces of attraction, V – volume, b – constant characterizing forces of repulsion, R – universal gas constant, T – temperature.

The theory explaining the complex of phenomena taking place on the solid-liquid (metal-polymer) boundary is based on analysis of intermolecular effects. The most important inter-planar interactions are the following:

1. Interactions of mechanical character,
2. Van der Waals forces:
 - dispersive forces,
 - orientation forces,
 - inductive forces,
 - conformational forces,
 - multi-polar forces,
3. Hydrogen bonds,
4. Chemical bonds.

The essence of interactions of mechanical character is presented in Fig.1.2. Generally speaking, it consists in mechanical “anchoring” of unhardened adhesive in micro-irregularities of bonded material surfaces.

Dispersive interactions

Analysing dispersive (London) interactions we treat atoms or molecules as oscillators. Oscillators have a natural frequency ν . It is a measure of energy required to excite an oscillator from its ground state. Every atom, due to the movement of electrons around the nucleus, is a dipole with a constantly changing dipole moment.

The energy of dispersive forces effect can be described by means of the relation [1.9]

$$u(r) = -\frac{3}{2} \frac{h}{r^6} \left(\frac{\nu_1 \nu_2}{\nu_1 + \nu_2} \right) \alpha_1 \alpha_2 \quad (1.6)$$

where: ν_1, ν_2 – natural frequencies of oscillators 1 and 2, α_1, α_2 – polarizability of oscillators 1 and 2, h – Planck constant.

Dispersive forces – are the result of the formation of elementary dipoles through the movement of electrons around the nucleus. They occur even when the molecule has no polar groups. The idea of their formation is presented in Fig.1.9.

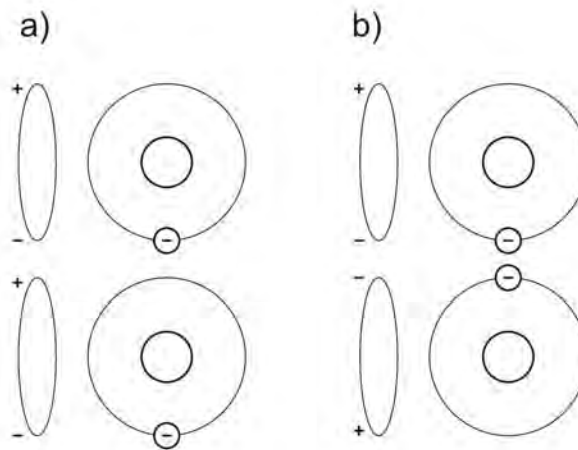

Fig. 1.9. Principle of generation of dispersive forces: A – of attraction, B – of repulsion [6]

Dispersive forces are additive and do not depend on temperature; their value increases with increasing number of outer electrons, atomic number, length of molecular chains, and number of function groups. They are also very strongly dependent on the proximity to the surface of bodies and decrease in proportion to the sixth power of the distance. Dispersion forces play a major role in processes of adhesive bonding.

Orientation interactions

These are interactions between permanent dipoles. If atoms in a molecule have different electro-negativity, then electrons concentrate around the atom with greater electro-negativity. As a result, in such a molecule there occurs a shift of charge and energy eccentricity and dipolar moment are created. These interactions are electrostatic in character and are referred to as Keesom interactions or Keesom forces [1.9]. The interactions are inversely proportional to temperature; with

increasing temperature the interactions weaken as a result of disturbed dipolar orientation. Also, like dispersive interactions, they decrease proportionally to the sixth power of distance.

Having considered the mean dipolar orientation, the energy of the interactions can be presented in the form [1.9]

$$u(r) = -\frac{2}{3} \frac{\mu_a^2 \mu_b^2}{(4\pi\epsilon_0\epsilon)^2 r^6 kT} \quad (1.7)$$

where: μ_a, μ_b – dipolar moments of interacting molecules, ϵ_0, ϵ – electric permittivity of free space and a medium, r – distance between molecules, k – Boltzman constant, T – absolute temperature.

The dipolar moment is the product of charge and the distance between charges

$$\vec{\mu} = q \vec{l} \quad (1.8)$$

where: $q \cong e = 1,6021917 \times 10^{-19}$ C, the distance is of the order of molecule size, i.e. $l \approx 10^{-10}$ m, hence the mean dipolar moment is $\mu \approx 10^{-29}$ Cm.

The range of forces of this type is approx. 40-50 nm.

Inductive interactions

These interactions are known as Debye forces [1.9]. They occur between non-polar molecules and permanent dipoles. A non-polar molecule located close enough to a molecule with permanent dipolar moment is subjected to the effect of a permanent dipole. As a result of that effect its electrons shift, charge eccentricity is formed, and dipolar moment is induced as a consequence. The importance of such interactions in adhesive processes is not excessively high, being estimated at approximately 10% of the sum of all intermolecular interactions.

The easiest to polarize are molecules with unsaturated bonds. The averaged value of energy of inductive interactions can be described by the relation

$$u(r) = -\frac{\mu^2 \alpha}{(4\pi\epsilon_0\epsilon)^2 r^6} \quad (1.9)$$

were: α – polarizability, μ – induced dipolar moment, ϵ_0 – permittivity of free space equal to $8.85416 \times 10^{-12} \text{ C m}^{-1}$, ϵ – relative permittivity of the medium, r – distance between charges

Conformational interactions

These are the result of changes in the positioning of atoms or groups of atoms. Rotation around the bond or a change in spatial orientation of atoms or groups of atoms cause differences in the energy status of molecules. These forces are additive with dispersive forces.

The idea of conformation is presented schematically in Fig. 1.10, on the example of rotation of a hydrocarbon chain

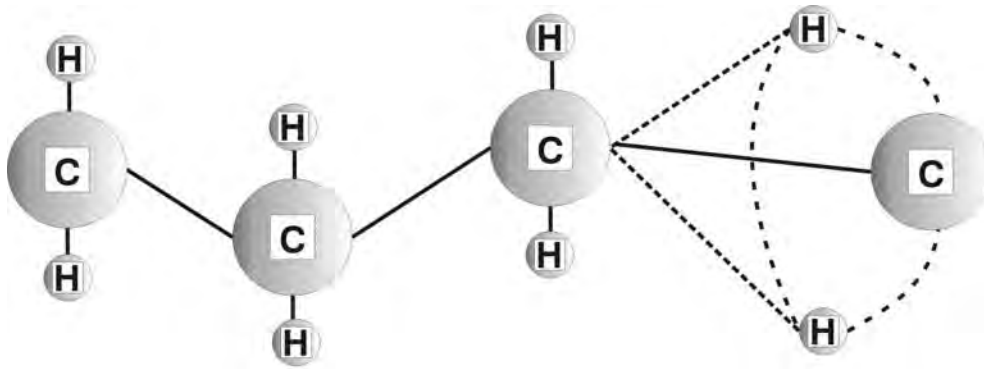

Fig. 1.10. Schematic presentation of conformation on the example of rotation of a hydrocarbon chain [1.12]

The contribution of conformational interactions to the strength of adhesive bonds is insignificant.

Multi-polar interactions

Multi-polar interactions are usually left out from considerations due to their low value. They occur commonly and are related to the problem of internal compensation of various components of dipoles in a molecule.

Total value of Van der Waals forces

The total energy of interaction between two dipolar molecules can be expressed with the relation [1.9]

$$u(r) = \frac{b}{r^n} - \frac{1}{r^6} \left(\frac{\mu_1^2 \mu_2^2}{kT} + \mu_1^2 \alpha_2 + \mu_2^2 \alpha_1 + \frac{3}{2} h \frac{v_1 v_2}{v_1 + v_2} \alpha_1 \alpha_2 \right) \quad (1.10)$$

The components in parentheses denote the interactions: dipole-dipole, dipole-induced dipole, and dispersive interactions.

In an abbreviated form the relation can be presented as follows:

$$u(r) = \frac{b}{r^n} - \frac{c}{r^6} \quad (1.11)$$

It can also be frequently encountered in the form of the 6–12 potential of Leonard-Jones [1.9]

$$u(r) = \frac{b}{r^{12}} - \frac{c}{r^6} \quad (1.12)$$

The curve of potential energy, illustrating the above relationship, is presented in Fig. 1.11.

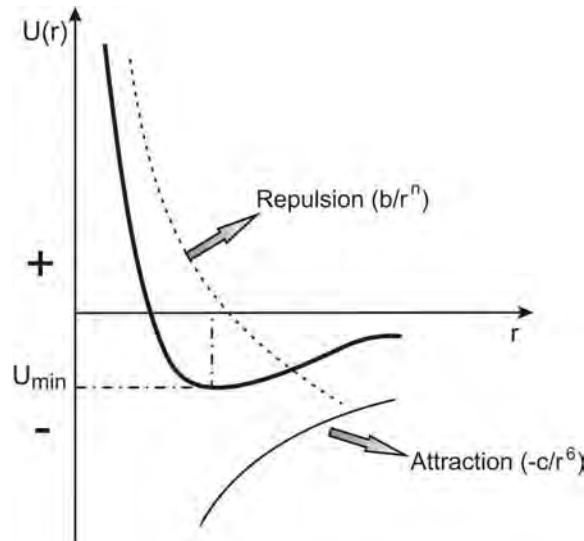

Fig. 1.11. Leonard–Jones curve of potential energy of potential [1.9]

The U_{\min} value corresponds to the most permanent status between the interacting molecules. The Leonard–Jones potential defines the relationship between the potential energy of molecules (atoms) and the distance between their nuclei.

Differentiating the above equation with relation to the distance between atom nuclei r we obtain the value of force of intermolecular interactions F [1.35]

$$F = -\frac{du(r)}{dr} = \frac{12b}{r^{13}} - \frac{6c}{r^7} \quad (1.13)$$

where: b – constant of repulsion, c – constant of attraction (characteristic for a given kind of molecules or atoms).

The following cases follow from the above relation

- for $r > \left(\frac{2b}{c}\right)^{\frac{1}{6}}$ - forces of attraction act between the atoms,
- for $r = \left(\frac{2b}{c}\right)^{\frac{1}{6}}$ - there is a balance between the forces of attraction and repulsion,
- for $r < \left(\frac{2b}{c}\right)^{\frac{1}{6}}$ - forces of repulsion act between the atoms.

In the technology of adhesive bonding we deal with the first of those cases, due to the fact that the range of effect of forces of attraction is much greater than of those of repulsion.

Without denying the importance of Van der Waals forces in the theory of adhesion, we should take note of the chemical bonds, as the forces of chemical bonds are greater than those of intermolecular forces by a factor of about 100. It is the chemical bonds that ensure great strength and are less sensitive to the desorptive effect of diffusive elements on the phase boundary. Reliability of adhesive bonds in long-term operation is determined, among other things, by the occurrence of chemical bonds.

Hydrogen bonds

This is a specific type of interactions with the participation of a hydrogen atom and two electro-negative atoms X and Y. Schematically, this can be presented as follows: X-H---Y. The X-H bond (e.g. O-H) is a covalent bond. Its length is approx. 0.1 nm. The distance of H-Y is approx. 0.176 nm and is less than the sum of van der Waals radii of oxygen and hydrogen, which is about 0.26 nm. The length of the hydrogen bond is therefore intermediate between the length of a covalent bond and the sum of van der Waals radii. The energy of hydrogen bonds falls within the

range of 15–50 kJ/mol and is greater than that of van der Waals interactions, but at the same time lower than the energy of covalent bonds.

Chemical bonds

These forces are a result of reorganisation of the atomic structure of the bonded surfaces due to their geometric proximity. The result of such a proximity may be the formation of covalent, ionic, hydrogen, and donor-acceptor types of bonds. Specially high energy characterizes covalent bonds (400–600) kJ/mol and ionic bonds (200–400) kJ/mol. The forces of adsorption and chemisorption are presented schematically in Fig. 1.12.

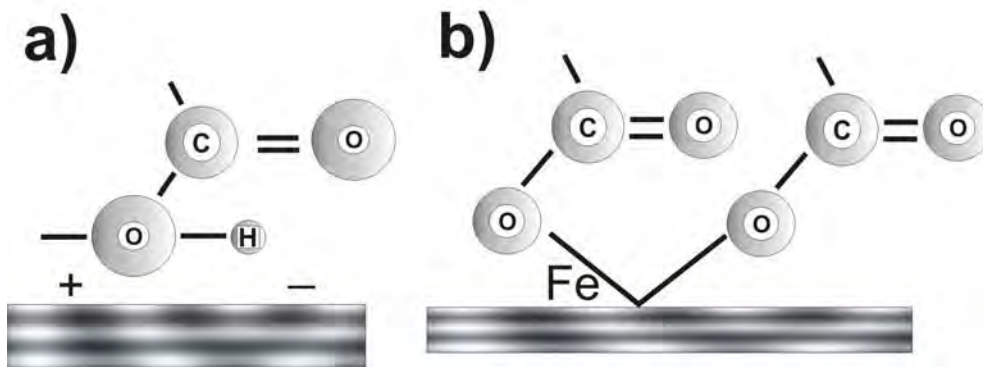

Fig. 1.12. Schematic presentation of the forces of adsorption (a) and chemisorption (b) [1.12]

Also other theories of adhesion are formulated, though their importance is lower. First of all we should mention here the electrical and diffusive theories of adhesion.

In the electrical theory of adhesion the forces of interaction result from interaction between the adhesive joints and the surface of the bonded bodies. They are generated through different values of the work of electron affinity, the result of which is the transfer of electrons from one material to the other. As a consequence, one of the layers becomes relatively poorer in electrons, which leads to the formation of a double electric layer causing the effect of attraction (like with the plates of a capacitor). The theory, however, is closely related with the adsorption theory, as the transfer of electrons causes oriented adsorption of polar groups of the adhesive on the surface of the bonded material, which is strictly related with the presence and number of polar groups.

The diffusive theory may be used solely for the interpretation of phenomena in adhesive bonds where the adhesive at least partially dissolves the material of the substrate.

Adhesive bonds of this type occur in the bonding of certain plastics.

1.4. Adhesion in molecular-kinetic approach

In the molecular description we employ models of atoms and molecules that take into account the molecular structure of the adhesive, the behaviour of macromolecules in the boundary layer, and their mutual interaction. Molecular models are always burdened with certain simplifications. Molecular-kinetic analysis assumes that the strength of an adhesive bond as a whole is the sum of mutual interactions of the adhesive and the surface on which it has been applied [1.33]:

$$R_{ad} = \sum_{i=1}^{k_0} U_i n_i \quad (1.14)$$

where: k_0 – number of types of interactions, U_i – energy of bonding of i -th type, $n_i = 0, 1, 2, 3 \dots$. This relation, after including the effect of deformation rate and temperature and assuming that the adhesive strength will be determined by destructive stress, assumes the form:

$$R_{ad} = K S n v e^{\frac{U}{RT}} \quad (1.15)$$

where: K – function of entropy of elementary decohesion, S – true contact area, n – number of elementary decohesions per unit of true contact area, v – bond breaking speed, U – energy barrier of elementary decohesion (energy of destruction process activation), R – gas constant, T – temperature. Molecular-kinetic analysis permits better understanding of many phenomena related to adhesion, but its applicability for the prediction of adhesive bond strength is limited. Phase boundary is a specific system whose properties are a function of many factors, and especially of intermolecular interactions.

The effect on adhesion may be considered on the atomic, molecular, and super-molecular level. Table 1 presents the relation of selected parameters of atomic structure to the adhesion properties of the surface layer.

Table 1. Relations of selected parameters of the atomic structure to the adhesion properties of the surface layer [1.21]

Parameter of atomic structure	Energy of surface layer E_w
- work of electron affinity ↑	↑
- atomic radius ↑	↓
- network constant ↑	↓ ↓
- number of free electrons ↑	↑
- ionizing potential (electro-negativity) ↑	↑
- polarizability ↑	↑

Direction of the arrows indicates direct or inverse proportion of the relation of E_w to the particular parameters of atomic structure [1.4, 1.36]. Two arrows indicate a strong relation.

Adhesive properties can be constituted at various levels of structure. Synthetic presentation of major factors affecting the adhesive properties of the surface layer, with reference to different levels of structure, is given in Table 2.

Table 2. Major factors affecting the adhesive properties of the surface layer, in relation to different levels of structure

Level of effect	Atomic	molecular and super-molecular	macroscopic
Major factors	atom radius	angles between bonds	fillers and carriers
	network constant	conformance	structure
	number of free electrons	configuration texturing	admixture modifying hardness, coefficient of elasticity, (stabilizers etc.)
	work of electron affinity	secondary structures	engineering of surface layer

From the practical point of view, especially in relation to polymers, the most important is the effect on the macroscopic level, and the surface layer engineering in particular. More detailed information on the possibility of constituting the adhesive properties of the surface layer can be found in Chapter 3.

1.5. Adhesion in thermodynamic approach

The surface of a solid is heterogeneous due to surface roughness and chemical composition. This is closely related to the processes of adsorption and adhesion. The surface can be characterized in terms of crystallography, topography, or chemistry. Each of those factors is closely related to the constitution of the adhesive properties. Crystallographic characterization refers to the positioning of the atoms and molecules of the solid – on the surface areas of varied crystallographic orientation are most often exposed, so we encounter polycrystallinity. This, in consequence, leads to energetic heterogeneity.

Chemically pure surfaces do not occur in practice. Even under vacuum the obtaining of a chemically pure surface is not an easy process, as it is not possible to totally remove contaminants adsorbed on the surface. The chemical composition of the transition phase differs from that of the inner (volumetric) phase. The relation of chemical composition understood in this way with the energetic properties of the

surface is obvious. Important works concerned with those complex problems have been presented by E.T. Dutkiewicz [1.9] and M. Żenkiewicz [1.36]

Topographic characterization is concerned primarily with so-called „development” of surface. More information on the problem and on its relation with adhesion properties is given in Chapter 3.

As a result of the processes of adsorption, molecules of the adhesive on the surface of a solid lose their freedom of movement, which means that their entropy decreases, as does Gibbs free energy. The process of adsorption involves participation of physical and chemical forces, hence the distinction of physical and chemical adsorption. Physical adsorption is a reversible process as a result of van der Waals interactions, and adsorbed molecules can move on the surface by means of translation motions.

Chemisorption is a result of the formation of chemical bonds between molecules of the adhesive and surface molecules of the bonded material. Depending on the type of adhesive used, the bonds can be ionic or coordination bonds. Chemical adsorption is preceded by physical adsorption.

As has been mentioned before, molecular-kinetic analysis of the problems of adhesion, and therefore „force” analysis, is not convenient in practice. Nowadays it is commonly accepted that energy analysis is the most practical. The fundamental concepts related to the analysis of the problem are surface tension and free surface energy. Very often, even in specialist literature, these concepts are treated as synonymous. Without going deep into the essence of the problem, we should state that surface tension σ is equal to the surface energy only in the case of single-component liquids. In the general sense we can write [1.33]

$$\sigma = \gamma_s + S \left(\frac{dF}{dS} \right)_T \quad (1.16)$$

where: γ_s – free surface energy, S – surface area, T – temperature.

For liquids $S(dF/dS)_T = 0$, while for solids F and S(dF/dS) are values of similar order, hence treating those values as identical is inconsistent, especially as the unit expressing surface tension (N/m) is a vector and the unit of surface energy a scalar.

With a considerable simplification we can assume that the free surface energy defines the force of electron bonds in the atoms of the surface of a material, i.e., in other words, the ability of those electrons to interact with neighbouring atoms of the surface.

The inner energy of a body is the sum of energy of translational and rotational motions of molecules, intra-molecular vibrations of atoms, atom nuclei, and others. The measure of surface energy is the work that has to be performed to transfer atoms or molecules from inside a body onto its surface.

Experiments show that the relation between the wetting angle and the surface tension is approximately linear. Adhesion and wetting are characterized by such thermodynamic values as surface tension on the liquid-gas boundary σ_{la} , on the solid-liquid boundary σ_{sl} , free surface energy σ_{sa} , and the limit wetting angle Q . The value of the limit wetting angle cannot be adopted as a clear-cut indicator as it depends on the properties of the contacting phases, presence of contaminants and admixtures, surface roughness, and other factors. The interaction of a liquid with the surface of a solid (Fig. 1.13) is characterized by the work of adhesion.

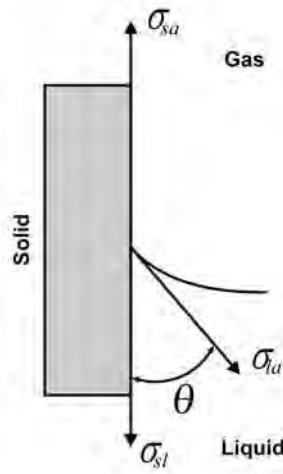

Fig. 1.13. Drawing facilitating the analysis of the process of solids wetting by a liquid

From analysis of solids wetting by a liquid there follows the well known Young equation [1.33]

$$\frac{\sigma_{sa} - \sigma_{sl}}{\sigma_{la}} = \cos \theta \quad (1.17)$$

where: $\sigma_{sa} = (dF/dS_{sa})_{T,\mu}$, $\sigma_{sl} = (dF/dS_{sl})_{T,\mu}$, $\sigma_{la} = (dF/dS_{la})_{T,\mu}$, represent the corresponding partial derivatives of Helmholtz energy, T – temperature, μ – chemical potential. The Young equation provides an approximated description of the state of thermodynamic balance, as it does not take into account the macro- and micro-angle of wetting. The angles are presented schematically in Fig. 1.14.

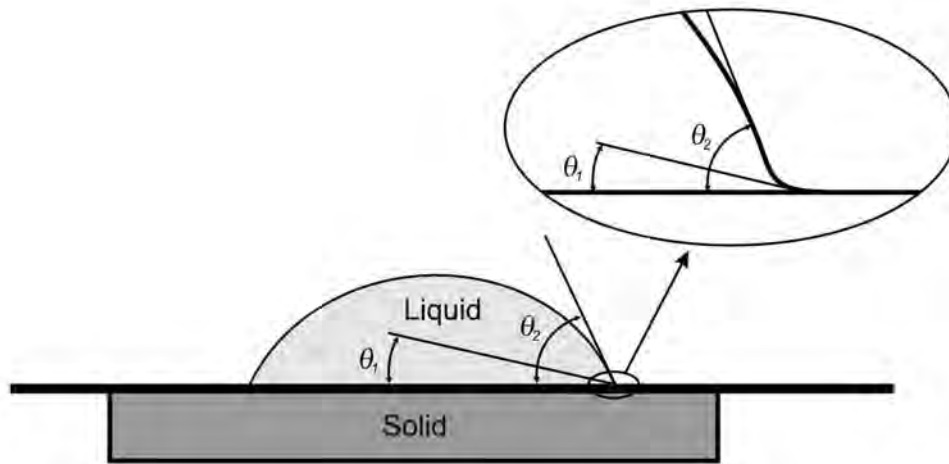

Fig. 1.14. Simplified model of a solid wetting by a liquid, including the macro- and micro-angle of wetting; θ_1 – micro-angle of wetting, θ_2 – macro-angle of wetting

The inclusion of the micro- and macro-angle of wetting in the energy analysis complicates somewhat the thermodynamic analysis of the process of wetting, so it is frequent for that aspect to be left out. Between the wetting angle and the surface tension there is, as shown by research, an approximately linear relation, though a strict relation is basically observed only when a given material is wetted with liquids belonging to a single homological series.

The Young equation has been modified by A. Dupre [1.33] who introduced the highly important concept of the work of adhesion W_{ad}

$$W_{ad} = \sigma_{sa} + \sigma_{la} - \sigma_{sl} \quad (1.18)$$

It should be noted that the commonly used Young equation does not include changes in surface energy, mutual dissolution of components at the phase boundary, and changes in their chemical potentials. In the practical approach the Dupre-Young equation is presented in the form

$$W_{ad} = \sigma_{la}(1 + \cos\Theta) \quad (1.19)$$

The unit work of adhesion can be determined by means of the relation

$$W_{ad} = -\frac{0,6A}{\Pi H^2} \quad (1.20)$$

where: A – van der Waals constant, H – distance between the contacting materials.

This relation is rather problematic in practical application due to the difficulties involved in the determination of the value of H . In principle the best would be to adopt the mean inter-atom distance of the materials bonded and of the adhesive, but this is not easy if we consider the chemical structure of both the adhesive and the bonded materials, frequently highly complex.

The ratio of the work of adhesion W_a (phase separation on the solid-liquid phase boundary) to the work of cohesion W_k (phase separation on the liquid-liquid phase boundary) is the relative work of liquid adhesion W_{wa} :

$$W_{wa} = \frac{W_a}{W_k} \quad (1.21)$$

The value of adhesion is described by means of the work required to separate bodies adhering to each other, per unit of surface area. For a homogeneous system, the work of adhesion depends primarily on the density of molecules, the constant of attraction, and on the equivalent distance. It should be noted that the work of adhesion is only a part of the work of interaction in real systems.

The work of cohesion is a measure of energy required to separate 1 mol of a given material into individual atoms or molecules and to bring them to the distance of decay of measurable effects

$$W_k = \Delta H_p - RT \quad (1.22)$$

where: H_p – enthalpy of evaporation of a given component, R – universal gas constant, T – absolute temperature.

There are many other relations defining the free surface energy and the work of adhesion, as functions of atom radius, dipolar moment, network constant, tensile strength, ionization potential, and other values, but it appears that – in spite of certain simplifications involved – the Dupre-Young equation is the most convenient in practical applications. This follows primarily from its energy- and force-related character. In the analysis of adhesive bonds the important thing is the relation between the work of adhesion and the work of cohesion. The work of cohesion is the energy that has to be supplied to the system to overcome the mutual interaction between molecules and to bring about their separation. Then two new surfaces are formed, so it is necessary to perform work equal to double the value of the surface energy

$$W_k = 2\sigma_{la} \quad (1.23)$$

This condition also follows directly from the Dupre-Young equation for $\theta = 0$, i.e. for perfect spread. On real surfaces the phenomenon of perfect spread does not occur, hence the work of adhesion is always less than the work of cohesion. The difference between the work of adhesion and the work of cohesion is the work or energy of spread.

Also, the concept of the wetting coefficient has been introduced

$$c = W_a - 2\gamma_l \quad (1.24)$$

If $c > 0$ then we can speak about good wetting.

The work of adhesion, however, cannot be used for the assessment of the adhesive properties of the surface layer of structural materials as it relates solely to the energy required for separating from the surface of the material only that liquid that has been applied. Therefore, it can only be used for comparative purposes. The indicator that is used for the assessment of adhesive properties is the free surface energy and the methods for its determination are presented in Chapter 8.

Free surface energy is a value dependent on many factors. From the practical point of view especially significant is its dependence on temperature and pressure. The relation of surface tension to temperature has been given by Eotvos [1.33]

$$\sigma V_m^{2/3} = k(T_c - T) \quad (1.25)$$

where: V_m – molar volume of liquid, $V_m^{2/3}$ – surface area of the sphere of 1 mol of the liquid, T_c – critical temperature, k – coefficient of proportionality. With increasing temperature the surface tension decreases.

The relation of surface tension to pressure is presented by the formula

$$\left(\frac{\delta\sigma}{\delta p} \right)_{A,T} = \left(\frac{\delta V}{\delta A} \right)_{P,T} \quad (1.26)$$

Change in surface tension caused by pressure leads to a change in volume through the transition of molecules from the volumetric phase to the surface phase.

At the critical state the surface energy equals zero, since the difference between phases disappears and therefore the surface disappears as well.

Surface energy is defined as the energy of atoms or molecules in the surface layer, but this is not an accurate formulation as the energy of atoms in the surface layer increases with increasing temperature, the surface energy σ_{sa} decreases, and at the critical temperature its value equals zero [1.33].

$$\sigma_T = \sigma_{293} + \frac{d\sigma}{dT}(T_a - 293) \quad (1.27)$$

where:

σ_{293} – surface tension at reference temperature, T_a – temperature under analysis.

The surface of crystalline solids differs from the surface of liquids in that its atoms or molecules have more restricted freedom of movement as they are „trapped” in the crystalline network. Increase in temperature causes an increase in the mobility of surface atoms or molecules. When a solid is heated to its melting temperature, there is a sudden increase in the mobility of the surface atoms, followed by their increased diffusion towards the core of the solid. At a temperature at which certain mobility of surface atoms occurs, there is a tendency towards energy equalization in areas in which it reaches high values, e.g. in pores, micro-slots, protrusions, and in areas with strong curvature.

An example of the mobility of atoms can be provided by the phenomenon of metal powder sintering at a temperature close to the melting point and under the effect of increased pressure.

The surface layer of a solid remains in a state of stress resulting from uneven distribution of forces acting on the surface atoms, usually causing a shift in their positions in the crystalline network. The various methods of surface treatment or effect of external factors on the surface may cause an increase or a decrease in that state of stress. Increase in the stress results in an increase in the surface energy.

The energy status of a physical surface is affected by the chemical composition, structure, and the course and conditions of the technological process of its obtainment. These factors constitute the subsurface zone. The status is not homogeneous, as due to the varied situation of macro-molecules, molecules and atoms, and to the various structural defects, some of them will be more and other less saturated with energy. Therefore, on the surface of a solid there are areas of varied energy activity, elements with weaker bonds being more surface-active. The adhesion between a liquid and a solid is constituted in a variety of ways that can be classified in the following groups:

- preparation of the surface layer of the material,
- chemical and physical modification of the liquid,
- change in the conditions of the liquid contact with the solid.

Preparation of the surface layer of the material consists in: removal of external absorption coatings of the subsurface zone, application of coating with suitable substances on the actual surface of the material or generation required coatings on the surface, or suitable combination of the two treatments [1.5, 1.24, 1.26].

Adsorption coatings are removed through machining, which usually involves also the removal of a part of the surface layer of the material and the generation of a new surface layer, characterized primarily by very low roughness. Therefore, machining treatments used include finishing grinding, buffing, electro-polishing, etc. Substances used to apply surface coatings are referred to as separators (anti-

adhesion agents). They also can have the character of adhesion promoters. Common anti-adhesion agents include various kinds of waxes and silica-based oils.

Therefore, the separation of the liquid from the solid takes place within the separating medium or agent.

If adhesion occurs as a desirable factor, the zone in which the separation takes place (liquid and solid) depends in fact on the same factors as before, the difference being in the use of other methods for the removal of external adsorption coatings on the subsurface zone and of generation of desired coatings on the true surface.

The adsorption coatings are removed through machining or other treatments, but the newly generated surface layer should be characterized first of all by a much greater roughness of surface. Types of machining used include abrasive blasting, especially dust-free sand blasting, abrasive blasting in containers, coarse grinding, and a variety of bench work techniques such as sandpaper, file, scraper, etc. However, machining does not fully remove certain adsorption coatings, e.g. greases. Therefore, in order to remove such coatings as much as possible, organic solvents are applied, such as acetone, extraction naphtha, methyl-ethyl-ketone, etc. In some cases chemical treatments are applied, e.g. etching with sulphuric, hydrochloric or nitric acid at different temperatures, ratios and concentrations, or electrochemical methods. A characteristic feature of crystalline bodies is the anisotropy of their properties, including the anisotropy of surface energy. This is the source of significant difficulties in the prediction of strength of adhesive bonds of metals. Due to the complexity of the problem, more and more frequently neuron networks are utilized for the prediction of such strength [1.32]. This is especially important in aerospace [1.19, 1.30] where adhesive bonding is the most commonly used method of joining.

References

- 1.1. Ashby M.F, Jones D.R.: *Materiały inżynierskie: kształtowanie struktury i właściwości, dobór materiałów*. WNT Warszawa 1996.
- 1.2. Bieliński M.: *Techniki porowania tworzyw termoplastycznych*. Wydawnictwa Uczelniane Akademii Techniczno-Rolniczej w Bydgoszczy. Bydgoszcz, 2004.
- 1.3. Borowski G., Kuczmaszewski J.: *Utylizacja drobnoziarnistych odpadów metalowych*. Wydawnictwa Uczelniane. Politechnika Lubelska, 2005.
- 1.4. Brojer Z., Hertz Z., Penczek P.: *Żywice epoksydowe*. WNT, Warszawa, 1998.
- 1.5. Burakowski T., Wierzchoń T.: *Inżynieria powierzchni metali*. WNT, Warszawa, 1995.
- 1.6. Cagle Ch.V.: *Kleje i klejenie*. WNT, Warszawa, 1997.
- 1.7. Cempel Cz.: *Wibroakustyka stosowana*. Warszawa. PWN, 1989.
- 1.8. Czaplicki J. i inni: *Klejenie tworzyw konstrukcyjnych*. Wydawnictwa Komunikacji i Łączności. Warszawa, 1987.
- 1.9. Dutkiewicz E.T.: *Fizykochemia powierzchni*. WNT, 1998.
- 1.10. Flizikowski J.: *Projektowanie środowiskowe maszyn*. Wydawnictwa Uczelniane Akademii Techniczno-Rolniczej w Bydgoszczy. Bydgoszcz, 1998.

- 1.11. Godzimirski J.: Wytrzymałość doraźna konstrukcyjnych połączeń klejowych. WNT, Warszawa, 2002.
- 1.12. Hebda M., Wachal A.: Trybologia. WNT Warszawa 1980.
- 1.13. Jurkowski B., Jurkowska B.: Sporządzanie kompozycji polimerowych. Elementy teorii i praktyki. WNT, Warszawa, 1995.
- 1.14. Jóska M.: Metodologiczne aspekty oceny przyczepności powłok regeneracyjnych metodą ultradźwiękową. Wydawnictwo Politechniki Poznańskiej. Poznań, 2002.
- 1.15. Kalinowski L.: Fizyka metali. PWN, Warszawa 1973.
- 1.16. Kelar K.: Chemia polimerów. Wydawnictwo Politechniki Poznańskiej. Poznań, 1991.
- 1.17. Kittel C.: Wstęp do fizyki ciała stałego. PWN, Warszawa 1976.
- 1.18. Koszkuł J.: Materiały polimerowe. Wydawnictwa Politechniki Częstochowskiej, 1995.
- 1.19. Kuczmaszewski J.: Technologia śmigłowców. WV, Politechnika Lubelska 1990.
- 1.20. Kuczmaszewski J.: Podstawy konstrukcyjne i technologiczne oceny wytrzymałości adhezyjnych połączeń metali. Wydawnictwo Politechniki Lubelskiej. Politechnika Lubelska 1995.
- 1.21. Kuczmaszewski J: Some methodological problems in assessing the adhesive properties of surface layer of plastics. Int. Pol. Sc. And Technology. Vol 29, No. 5, 2002.
- 1.22. Kuczmaszewski J., Rudawska A.: Klejenie i uszczelnianie w technologii montażu. Technologia i automatyzacja montażu 3/1997.
- 1.23. Kupczyk M.: Jakość technologiczna i użytkowa ostrzy skrawających z po-włokami przeciwwzyciowymi. Seria Rozprawy, nr 320. Wyd. Pol. Poznańskiej, Poznań, 1997.
- 1.24. Legutko S.: Podstawy eksploatacji maszyn. Wyd. Polit. Poznańskiej. Poznań, 1999.
- 1.25. Mazurkiewicz S.: Właściwości mechaniczne i zastosowania termoplastów. Politechnika Krakowska, 2003.
- 1.26. Oczóś K.: Kształtowanie materiałów skoncentrowanymi strumieniami energii. Wyd. Uczeln. Pol. Rzeszowskiej, Rzeszów, 1988.
- 1.27. Piaseczny L.: Technologia polimerów w remontach okrętów. Gdańskie Towarzystwo Naukowe. Gdańsk, 2002.
- 1.28. Sikora R.: „Tworzywa wielkocząsteczkowe. Rodzaje, właściwości i struktura”. Wydawnictwo Uczelniane, Lublin 1991.
- 1.29. Sikora R.: Leksykon Naukowo-Techniczny. Wadim Plast Lublin, 2002.
- 1.30. Szabelski K., Jancelewicz B., Łucjanek W.(red.): Wstęp do konstrukcji śmigłowców. Wyd. Komunikacji i Łączności, Warszawa, 1995.
- 1.31. Szlezyngier W.: Tworzywa sztuczne. Oficyna Wydawnicza Politechniki Rzeszowskiej. Rzeszów, 1996.
- 1.32. Tadeusiewicz R.: Sieci neuronowe. Wyd. 2. Akademicka Oficyna Wydawnicza. RM, 1993.
- 1.33. Wakuła W. Ł., Pritikin Ł., M.: Fiziczeskaja chimija adgiezji polimerow. Moskwa, Chimija, 1984.
- 1.34. Wilczyński K.: Reologia w przetwórstwie tworzyw polimerowych. WNT, Warszawa, 2001.
- 1.35. Zaczek Z.: „Studium wytrzymałości statycznej i odporności na działanie środowiska klejonych połączeń metali i laminatów szklanych”. Wydawnictwo Wyższej Szkoły Marynarki Wojennej, Gdynia 1973.

-
- 1.36. Żenkiewicz M.: Adhezja i modyfikowanie warstwy wierzchniej tworzyw wielkocząsteczkowych. WNT, Warszawa, 2000.
 - 1.37. Żuchowska D.: Polimery konstrukcyjne. WNT, Warszawa, 1995.

Chapter 2

Adhesives

2.1. General characteristics

Adhesive bonding as a method of joining was known already in ancient times. Around 3000 BC, in Egypt, papyrus reeds were used to make writing material. Stem sections were cut open to remove the core that was then placed crosswise in two layers and hammered with a mallet until natural glue bonded the cores into a homogeneous sheet. In the same period lime mortar, in its essence a glue, was used to join bricks. Around 1500 BC, in Egypt, a gelatine glue was used, prepared from animal hide. The ancients used also casein glues, as well as glues prepared from birch bark. A major breakthrough in the production and application of adhesives occurred with the appearance of synthesis of epoxy resins in the nineteen thirties. Up till now adhesives based on epoxy resins are the most commonly used and find the broadest range of applications [2.1].

The more important features of a good adhesive for metal bonding can be presented synthetically as follows:

- strength when cured meeting the requirements,
- possibly low viscosity, facilitating wetting,
- relatively low free surface energy,
- presence of various functional groups in the chemical structure of the adhesive, expanding the applicability of the adhesive and permitting the formation of chemical bonds,
- low chemical curing shrinkage rate, in the case of thermal-setting adhesives also low thermal cure shrinkage rate; this permits bonding under contact pressure,
- possibility of curing at ambient temperature,
- short curing time,
- resistance to cracking of brittle character.

A good adhesive for metal bonding should contain as many various functional groups as possible, capable of the processes of chemisorption with the material of the substrate. Its chemical structure should impart to it high cohesive strength as well as elasticity to guarantee good damping properties and ability to “absorb” stresses.

Functional groups play a highly significant role in the chemical structure of adhesives. They permit the formation of chemical bonds between the adhesive and the substrate and determine high strength of the joint. The most important functional groups, significant in the theory of adhesion, are the following [1, 10]:

- ester groups $-\text{OCO}-$, OCOR , $-\text{COOR}$,
- hydroxyl groups $-\text{OH}$,
- amino or imino groups $-\text{NH}_2$, $=\text{NH}$,
- carboxyl groups $-\text{COOH}$,
- acetal groups $-\text{CH}(\text{OR})_2$,
- epoxy groups $-\text{CH}-\text{CH}_2$
 $\quad \quad \quad \diagdown \quad \diagup$
 $\quad \quad \quad \text{O}$
- isocyanate groups $-\text{NCO}$,
- urethane groups $-\text{NHCOO}-$,
- urea groups $-\text{NHCONH}-$,
- amide groups (in the primary chain or as substituents) $-\text{NHCO}-$, $-\text{CONH}_2$,
- nitrile groups $-\text{CN}$,
- chloride, bromide $-\text{Cl}$, $-\text{Br}$,
- hydrosulphide group $-\text{SH}$,
- vinyl group $-\text{CH}=\text{CH}_2$.

The groups occur in the following more important materials:

- polyvinyl acetate and its copolymers; these adhesives occur in the form of solids or as solutions with solvents, or else as water dispersions,
- polyacrylates and polymethacrylates and their copolymers; these, as a rule, are typical thermoplastic adhesives, popular in various branches,
- polyvinyl acetals, thermoplastics used primarily as modifiers of structural adhesives, due mainly to their good adhesive properties in contact with metals,
- polyamides, thermoplastics with good strength characteristics, frequently used as modifiers for structural adhesives; as solutions in certain organic acids they are used for bonding elements of polyamide,
- polyvinyl chloride; in adhesives it occurs in the form solutions (for bonding tubes of PVC) or in the form of plastisols, i.e. special mixtures with fillers and plasticizers that provide a good combination of the functions of bonding and sealing – used in the automotive industry, among others,
- rubbers, especially styrene-butadiene, nitrile and chloroprene rubbers, are used in the production of adhesives commonly known as latex adhesives; admixture of vulcanising agents results in crosslinking of rubbers, producing non-soluble and flexible adhesive bonds; also used as modifiers in other structural adhesives,
- polyesters, used in hot-melt adhesives as saturated thermoplastic polyesters; unsaturated polyester resins, in the form of solutions in styrene, are used in the production of glass fibre-polyester composites; also used as fillers or surfacers,
- polyurethanes; a large group of materials based on pre-polymers and urethane rubbers, used both as solvent and as non-solvent adhesives, and also as hot-melt adhesives,

- phenolic resins are excellent material for structural adhesives, but their share in the production of adhesives is rapidly declining due to their toxic effect on human organism; for this reason there is an ongoing search for new solutions, e.g. through the modification of epoxy resin with phenolic resin, which leads to the creation of highly interesting adhesives – epoxy novolacs,
- epoxy resins provide the base for highly versatile all-purpose adhesives, occur in various forms, are characterized by good strength properties when cured and by good chemical resistance, which makes them inert in contact with various media; that last property makes them suitable for use in the food processing industry,
- acrylic and methacrylic monomers, and also certain resins ending with acrylic and methacrylic groups, constitute an interesting modern group of adhesives cured with UV radiation and groups of anaerobic adhesives.

Adhesive bonding is characterized by numerous well-known advantages. In the case of metal bonding the major advantages of adhesive bonds are as follows [2.4, 2.9]:

- possibility of bonding metals with materials of specific properties, e.g. foils, paper, fabrics; it is frequent in such cases that adhesive bonding is the only applicable technology,
- possibility of bonding very small elements,
- easy and fast joining of large surfaces,
- possibility of simultaneous joining and sealing of structures,
- electrochemical insulation of elements joined, protection against the formation of electrochemical corrosive cells,
- elimination of negative effect of heat on the properties and structure of elements joined as is the case with welding, spot welding, or soldering,
- ease of modification of adhesives, both physical and chemical, which permits the obtainment of desired physicochemical properties of the bond formed,
- possibility of creating bonds under highly specific conditions, e.g. in field conditions, under water, etc.,
- possibility of creating bonds using simple equipment, which provides significant reductions in costs.

Among the factors that restrict the application of the technology we should enumerate the high sensitivity of the physical properties of adhesive bonds to deviations from the recommended technology, non-linear relation of the strength of adhesive bonds with the size of the surface area of bonding, limited resistance to high temperatures. These, however, do not significantly reduce the applicability of adhesive bonding.

2.2. Classification of adhesives

With a certain simplification, polymer plastics can be classified into structural, adhesive, and coating. Adhesive plastics are materials in which use is made of their exceptional adherence to various materials. Fig. 2.1 presents a simplified classification of those plastics.

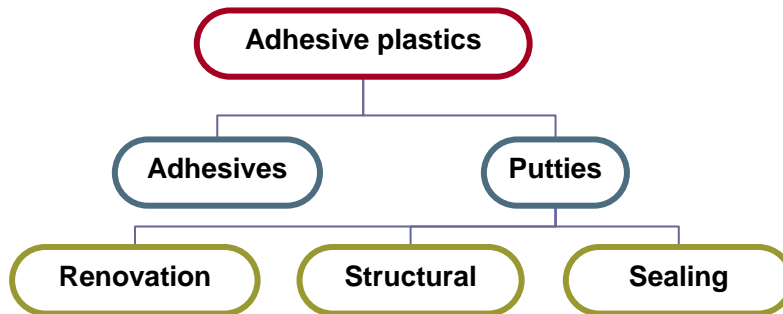

Fig. 2.1. Classification of adhesive plastics

Adhesives are materials that possess the capability of permanent joining elements of structures. An important feature of adhesives is their high strength when cured. Among other things, the strength is a function of the thickness of the layer of adhesive. It is conventionally assumed that the thickness, in structural adhesive bonding, does not exceed 0.5 mm.

Putties are adhesive materials whose significant feature is their considerable viscosity. This permits putties to perform a variety of functions.

Structural putties are adhesive plastics that permit the constitution of bonds that have the capability of permanent bonding combined with sealing of structures. Typical representatives of structural putties are epoxy putties in which metal powders act as fillers. The putties ensure high strength of bonding at layer thickness above 0.5 mm, so there is a possibility of filling with them gaps of notable dimensions while ensuring high strength of bonding.

Sealing putties, as a rule, do not transmit mechanical loads – their function is to seal structures against environmental effects. These materials usually have to meet stringent requirements concerning the rate of water vapour diffusion and resistance to ageing in the environment in which they are to be operated, including resistance to UV radiation, cyclic changes of temperature, etc.

Renovation putties are modified adhesive plastics. The modification, most frequently physical, consists in the addition of powder fillers to resins, the function

of the fillers being to constitute putty properties similar to those of the parent material. What is especially important here is similar coefficients of thermal expansion, good machining properties, stability of dimensions in contact with various media, frequently also similarity of colour and other features that may be important is a specific design and technological situation.

Adhesives can also be classified taking into consideration such criteria as the origin of the base substance, type of solvent, form, manner of bonding, etc. Basing on such criteria we can distinguish the following types of adhesives:

- aqueous adhesives – water is the solvent,
- solvent adhesives – most frequently the solvent is an organic solvent,
- dispersion adhesives – also known as emulsion adhesives, are colloidal suspensions of pulverized adhesive in a liquid,
- hot-melt adhesives – at ambient temperatures they occur as solids, attaining their adhesive properties when heated up to the melting point,
- chemically setting adhesives – the process of their setting or curing takes place as a result of a chemical reaction,
- thermosetting adhesives – the process of their setting or curing occurs under the effect of high temperature,
- anaerobic adhesives – adhesives whose setting begins when isolated from the effect of air,
- single component adhesives – adhesives available in a ready-to-use form,
- multi-component adhesives – most frequently two-component adhesives; the base component can be made up of many components and the second component is the hardener or curing agent.

With relation to the character of the curing process we can distinguish:

- solvent adhesives – the process of their curing is physical in character and takes place through the evaporation of the solvent,
- cold or warm setting adhesives – the process of their curing takes place through suitable chemical reactions occurring spontaneously at higher temperature and when cold, with the addition of a proper hardener or curing agent,
- anaerobic and cyanoacrylic adhesives, cold setting; their setting reactions are catalysed after cutting off the access of air (anaerobic) or under the effect of residual moisture remaining on the surfaces of the bonded elements,
- other adhesives, in which the reaction of setting can be catalysed by light, radiation, etc.

With respect to their form and texture, adhesives can be classified as:

- solid adhesives (granules, sticks, block, films),
- liquid adhesives,
- powder adhesives,
- aerosol or spray adhesives,
- adhesive foams,

- adhesive tapes.

With relation to the origin of the base component, adhesives can be divided into the following groups:

- vegetable glues (dextrin adhesive or British gum, starch glue),
- animal glues (bone glues, hide glues, casein adhesives),
- adhesives based on cellulose derivatives (nitrocellulose, on the base of cellulose ethers),
- adhesives based on synthetic resins (phenolic, amino, on the base of vinyl derivatives, epoxy, polyester, polyurethane, on the base of derivatives of poly-acrylic and polymethacrylic acids),
- adhesives based on natural rubber and synthetic rubbers (on the base of butadiene copolymers, polychloroprene rubber, thiocol rubbers, etc.),
- gypsum adhesives,
- ceramic adhesives.

Classification of adhesives with relation to their raw material origin, and their more important applications, are presented in Table 2.1.

Table 2.1. Classification of adhesives with relation to raw material origin and their more important applications [2.5, 2.6, 2.8, 2.9, 2.10]

Item	Raw material base	More important applications
1	Dextrin adhesives	For bonding paper, cardboard, wood, leather
2	Starch adhesives	For bonding paper and cardboard
3	Adhesives based on rosin	Used as admixture to paper pulp to give liquid-resistance properties to paper products
4	Bone glues	For bonding paper, textiles and wood
5	Hide glues	For bonding wood, textiles, paper, cork, for water-resistant impregnation
6	Casein adhesives	For bonding wood, cardboard, leather
7	Nitrocellulose adhesives	For bonding leather, textiles, felt, cork, cardboard
8	Adhesives based on cellulose ethers	For bonding wallpaper, paper, leather
9	Phenolic adhesives	For bonding wood, metals, ceramics, glass, thermosetting plastics
10	Amino adhesives	For bonding wood, paper, cardboard, tar board, textiles, felt, laminates, rubber
11	Adhesives based on polyvinyl chloride	For bonding PVC, for wire insulation

12	Adhesives based on polyvinyl acetate	For bonding wood, paper, cardboard, textiles, cork, leather, felt, floor lining materials
13	Adhesives based on polyvinyl acetal	For bonding metals, glass, thermosetting plastics
14	Adhesives based on copolymers of vinyl and terpolymers	For bonding paper, tiles and floor lining materials, fibreboards, and for furniture veneering
15	Adhesives based on polyacrylic acid and its derivatives	For bonding metals, polymer plastics, rubber, glass, ceramics, cork, paper
16	Adhesives based on polymethacrylic acid and its derivatives	For bonding leather, polymer plastics (PMMA, ABS, etc.), for sealing of metal elements, laminated composites
17	Epoxy adhesives	For bonding metals, ceramics, glass, concrete, wood, rubber, polymer plastics, also for renovation, casting
18	Polyurethane adhesives	For bonding metals, wood, glass, rubber, leather, polyamides, PVC, foamed polystyrene, mineral wool
19	Adhesives based on natural rubber	For bonding rubber, leather, felt, textiles
20	Adhesives based on butadiene rubber	For forming plates of sintered carbides
21	Adhesives based on butadiene copolymers	For bonding PVC to concrete base
22	Adhesives based on polychloroprene rubber	For bonding rubber, leather, textiles, felt, also rubber to metal
23	Adhesives based on thiocol rubbers	For bonding and renovation of conveyor belts
24	Silicon adhesives	For bonding lamps, transformers, equipment operated at high temperatures (even above 300 ⁰ C)
25	Gypsum adhesives	For fixing plates, for other joints, especially in building construction
25	Ceramic adhesives	For joining elements of casting moulds, tooling plates; operating temperatures even up to 1500 ⁰ C

It should be mentioned that competition on the market of adhesive materials causes the offer to be extremely diversified, and moreover in most groups of products there is a possibility of modifications of chemical or physical character.

One can safely venture a statement that the world market offers on a permanent basis several thousand brands and types of adhesives for metal bonding.

2.3. Applications of adhesives

In machine building adhesive bonds perform a variety of functions, depending only on what types of functions are the most required. Table 2.1 presents certain applications of adhesives in the context of their raw material origin. With regard to their application, adhesives can be classified in the following major groups:

- adhesives for high-strength structures, replacing welding, riveted joints, spot-welded joints, pressed-in joints, bolted joints, etc,
- adhesives cured under specific conditions, e.g. under water,
- adhesives with enhanced thermal resistance,
- adhesives for aircraft and spacecraft, the primary requirements with relation to which include durability and reliability over long periods of time under highly specific environmental conditions,
- adhesives conducting electricity, most frequently with metallic fillers (flakes of silver, copper); adhesives based on electro-conducting polymers are at the stage of laboratory testing,
- adhesives with good thermal conductivity, for the assembly of heat generating parts,
- adhesives with low dielectric constant, for high impedance circuits, highly important in telecommunications applications,
- adhesives with enhanced elasticity, for the electronic industry, permitting replacement of damaged elements without destroying printed circuits, and thus allowing for the design of “partially-temporary fastenings”,
- high-temperature creep resisting adhesives, produced on the base of inorganic materials,
- adhesives with specific properties, e.g. conducting electricity or heat fluxes or magnetic fluxes,
- adhesives for nano-devices, a new generation of light-cured adhesives,
- adhesives for operation in very high temperatures,
- fast-setting adhesives,
- so-called adhesive „drops”. Produced with various levels of gluing power and confectioned as tapes with individual drops of glue. Used for mass-scale bonding of promotional kits to high-volume papers and magazines, for enveloping, labelling, attachment of additional elements in large-scale or mass production, etc. One tape (roll) can contain several thousand drops of adhesive.

Modern assembly adhesives are usually characterized by short curing times and harden at room temperature and under contact pressure.

Among major examples of the application of adhesives in machine building we can mention the following [2.3, 2.4, 2.13]:

- securing nuts and bolts from coming loose,
- joining and sealing of tube and flange connections and joints,
- application of bonded trunnion-sleeve joints to replace forced-in joints,
- mounting gears and pulleys on shafts using adhesive bonding,
- production of special structures, e.g. „honeycomb”,
- production of sandwich-type layered structures, such as paper, glass-epoxy, polyester, phenolic composites, etc.,
- joining of structural elements of very small dimensions,
- joining of structural elements with different physical features, e.g. thin foils of polymer plastics with metals,
- connection of electronic elements on printed circuit boards,
- installation of decorative, protective and soundproofing linings in cabins of vehicles; also in other equipment,
- sealing of structures,
- other.

The presented examples of the application of adhesive bonding in machine building industry do not exhaust the extensive and constantly expanding list of adhesive bonding application in building machinery and equipment. Observation of the rapid and intensive development of the chemistry of adhesives shows that the prospects for their new applications are highly promising.

2.4. Sealants and renovation putties

Sealing of structures often plays an important role in the machine building industry. Requirements relating to sealants are very varied. Sometimes it is a specific level of adhesion that is required, like in sealing electric devices, sometimes high surface energy value (like in applying paint coats on sealed structures), and sometimes ensuring fluid- or air-tightness at high pressures or at elevated temperatures. Examples of sealing adhesives, with remarks on the application, are presented in Table 2.2.

Adhesive sealing materials are used primarily in static technical seals, though there are numerous cases of applying such materials in dynamic sealing and in static-dynamic seals.

Among sealants we can distinguish the following:

- sealants for sealing and bonding various elements (e.g. threads),
- seal-lock adhesives for protecting metal elements, forming various connections (e.g. bolt-nut joint, trunnion-sleeve joint), from coming loose or dropping out,
- sealants for valves, pipes, tanks, etc,
- filler compositions for electro-technical equipment,
- sealants for aircraft, cold storage equipment, etc.

Table 2.2. Examples of sealants and their more important applications [2.1, 2.2, 2.8]

Item	Raw material base	More important applications
1.	Silicon putties, produced on the base of polysiloxanes	For sealing of glass, natural stones, with lasting and high elasticity. Used for sealing of structures operated under atmospheric conditions. High resistance to UV radiation, technological difficulties in application of paint coating.
2.	Acrylic putties, produced on the base of acrylic dispersion	Limited thermal resistance, high rate of shrink during hardening
3.	Butylene putties, produced on the base of polybutylene	Putties with permanent plasticity, used primarily in building construction
4.	Polyurethane putties	Used mainly as assembly foams. Application – joining and sealing of structures (containers, cold storage equipment)
5.	Polysulfide putties	Good adhesion, also to smooth surfaces
6.	Silicate putties	High thermal resistance; used for reworking of casting moulds, dies
7.	Hybrid putties	MS Polimer can be an example of a hybrid putty; combines well the functions of bonding and sealing
8	Anaerobic putties	Anaerobic sealants are recommended, among other things, for mounting rings on shafts or bearing bushings (sleeves) in casings

The typical classification of putties into structural, sealing and renovation or reworking putties is a very general division; a significant group is made up of special putties, frequently prepared according to recipes developed by process engineers on the basis of specific company experience. With respect to form, sealing materials can be divided into the following major groups:

- sealing tapes,
- sealing ropes,
- foams,
- gaskets,
- sealants (mixtures or compositions).

Several examples of special putties are given below [2.1, 2.8]:

A. Aquarium putty

- chalk (2 parts by weight),
- red lead (1 part by weight),

- linseed oil varnish, until reaching the consistence of a paste.
- B. Filler putty for wood**
 - gypsum (3 parts by weight),
 - very fine wood shavings (1 part by weight),
 - joiner's glue, preferably heated to the right consistence.
- C. Fireproof putty**
 - zinc oxide (1 part by weight),
 - manganese dioxide (10 parts by weight)
 - water, until reaching the right consistence.
- D. Filler putty for metals**
 - Epidian 5 or Epidian 57 commercial epoxy resin,
 - curing agent at correct ratio,
 - powdered aluminium, till reaching the right consistence, possibly toluene as a solvent.
- E. Filler/surfacer putty for epoxy or polyester composites (e.g. boats, surfboards)**
 - Epidian 5 or Epidian 57 commercial epoxy resin,
 - curing agent at correct ratio,
 - silica gel.

Renovation or repair/rework putties are materials commonly used in machine overhaul and repair [2.13]. Among the various applications of such putties we can mention, among others, reworking of shaft trunnions, key grooves, pump casings, fans, piping fixtures, fuel tanks, hydraulic pistons and cylinders, pipelines, heat exchangers, belt and worm conveyors, repair of casting defects, etc. The putties are most frequently materials based on modified epoxy resins, where the fillers –as a rule – are powdered metals. The essence of modification of such putties is to obtain putty properties as similar as possible to those of the material repaired/reworked.

Through proper combinations of chemical and physical modifications we can achieve interesting properties of the renovation/repair material.

2.5. Adhesive components and modification

Solvents are used to reduce the viscosity of adhesives. Most frequently, esters, ketones or alcohols are used for the purpose. To reduce the viscosity of epoxy resins, one of the basic materials for structural adhesives, an admixture is added (approx. 10 – 20)% of active solvents, e.g. n-butylglycide ether or mono-epoxy compounds of low viscosity.

The more important solvents include the following [2.1, 2.10]:

- toluene (washing metal parts of greases and oils, cleaning tools),
- xylene (solvent for oil, phthal, acrylic, chlorinated rubber paints),
- acetone (for surface degreasing, tool washing, removes greases, waxes),

- painter's naphtha (paints, varnishes, phthal products, bituminous products),
- extraction naphtha (greases, oils, waxes, tool washing)
- gum turpentine (lowers the surface energy of varnishes),
- terpen (lower grade substitute for gum turpentine),
- other solvents, like methyl-ethyl-ketone, methyl-isobutyl-ketone, methylen chloride, ethyl acetate, extraction naphtha, benzene, isopropyl alcohol, chlorobenzene, cyclohexanone, dibutyl phthalate, styrene, amyl alcohol, phenol-glycidyl ether.

To improve the flexibility of the bond, plasticizers are used. In the case of adhesives, the application of plasticizers should be preceded with an analysis of results. Improvement of bond flexibility is usually advantageous, but plasticizers may also cause a deterioration in some other properties of the bond, e.g. tensile strength.

The more important plasticizing agents are the following: dibutyl esters of phthalic acid, hydrocarbon resins, copolymers of maleic anhydrite with styrene, rosin and its esters.

Fillers are introduced to polymers for the purpose of oriented modification of their properties, or else to reduce their price. With regard to their form, fillers can be divided into powdered, fibrous, sectioned or fragmented, ribbon-shaped, sheets, flakes, balls, and others.

The chemical composition of fillers may be various. Most frequently they are silicates, aluminosilicates, oxides, carbonates, powdered metals, etc. [2.10]. The effects obtained through the introduction of fillers to a polymer matrix may be highly varied, and most often concern the following properties:

- change in tensile and compressive strength,
- change in impact strength,
- change of coefficient of elasticity of elongation,
- change of coefficient of thermal expansion,
- cost reduction,
- reduction of processing shrinkage,
- improvement of thermal stability,
- improvement of chemical resistance,
- increase of thermal conductivity,
- change in electrical conductivity,
- improvement of abrasive resistance.

The more important fillers are the following: wood flour, cellulose fibre, mica, glass fibre, carbon fibre, graphite fibre, glass marbles, whiskers, organic synthetic fibre, chalk, talcum, quartz flour, graphite flour, powdered aluminium, carbon black (soot).

In the case of modification of adhesives, fillers are most frequently used in the form of powders, flakes, more rarely marbles (ballotini) or short fibres; the amount of filler to be used is determined experimentally.

Powdered fillers play a special role in physical modification of adhesives. As a rule, fillers with average grain size above 50 μm are treated as coarse-grained, those with grain size within the range of 10–50 μm as medium-grained, and when the average grain size is less than 10 μm such fillers are considered to be fine-grained. Powder fillers may be spherical, platelet or needle-like in shapes. Among the numerous group of powder fillers, powdered aluminium is of special importance. It can be used for significant modification of the rheological properties of adhesives, their stiffness, thermal conductivity, mechanical strength. Also important are chalk fillers, especially for the modification of lutes and putties. Quartz flours, in turn, improve abrasive resistance, dielectric properties, as well as acid resistance. Manganese and titanium oxides improve stiffness, hardness, and creep resistance under load. Fillers of heavy metals improve resistance to radiation. Powdered zinc oxide increases the resistance to atmospheric influences.

In certain cases also other modifiers are employed. These can be thixotroping agents, altering the rheological characteristics of liquid adhesives, biostabilizers, providing protection against biodegradation, agents reducing flammability, and others.

Promoters of adhesion

In many cases, to obtain an effective bond it is necessary to apply special intermediate layers or coats, or else special compounds or agents activating the bonded surfaces. More important compounds used for such purposes include the following [2.7]:

- resorcinol-formaldehyde resins,
- phenol-formaldehyde resins,
- chlorinated rubber resins,
- solutions of silanes,
- melamine and its derivatives,
- cobalt naphthenates, cobalt salts, mixtures of cobalt chloride and borate,
- polar modified polymers (epoxy resins, chlorinated rubber resins, natural rubber, carboxyl rubbers).

2.6. Special adhesives

Adhesive bonding of metals is sometimes used in special structures or operated under specific conditions. This concerns, among other things, bonded joints in spacecraft structures, underwater repair work, bonding in electronics. In spacecraft building, adhesive bonding is highly important due to the constant need for weight reduction. As a rule, the materials used are thin-walled, and it is also frequent to

join materials with different properties. In this type of situations adhesive bonding is the only joining technology possible. Also very often in such situations the adhesives used act also as sealants, insulation materials, shock absorbing elements. Spacecraft spend periods of several to close to twenty years under conditions of cyclic temperature changes, with lower extremes attaining values down to -200°C , and also are exposed to the effect of ultraviolet and ionizing radiation. Most frequently used in the „space” industry are modified epoxy adhesives, epoxy-phenol, epoxy-polyester, also adhesives containing polyurethanes, silicones, cyanoacrylates, and others [2.1]. Among other applications, they are used for thermal coatings, detectors, bands, insulations, antennae, plate structures for solar photocells, and others. What is especially important here is that under the effect of high vacuum there is no evaporation of low-molecular or volatile substances, as they might weaken the structure, cause a deterioration in the status of tightness, impair the optical properties of instrumentation.

Adhesives for repairs in water environment are used in emergency situations, e.g. for the repair of various types of vessels or watercraft. As a rule, those are adhesives of high stickiness or putties. In operations of underwater bonding it is important for water not to dissolve the adhesive, but also important is the opposite mechanism – it is desirable that the adhesive should desorb water from the bonding zone [2.14].

A specific group of adhesives is that of adhesives for the power industry and for electronics [2.11]. The power industry takes advantage of their good dielectric properties. For this reason adhesives are used not only as conventional glues but also as filling compositions and coatings with good dielectric properties. Thermoplastic adhesives have additionally the advantage that bonds made with their use may be treated as temporary, which is extremely important in the technology of replacement of worn out or blown electronic elements. For assembly or installation both conducting and non-conducting adhesives can be used. The idea of multi-layer assembly with the use of non-conducting adhesive is presented in Fig. 2.4 [2.12].

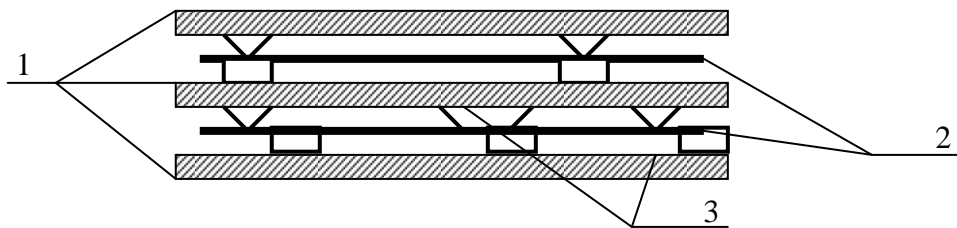

Fig. 2.4. Principle of multi-layer assembly using non-conducting adhesive: 1 – skeleton plates, 2 – non-conducting adhesive (film), 3 – contacts of conducting material

A film of adhesive is placed on a formed base plate with elevated contacts. Next, after careful positioning, pressure is exerted, causing the adhesive film to be

punctured by the terminal contacts. Correct wetting of the terminals is achieved by heating the bond area. The pressure is relieved only after the bond has cooled down and the bond produced is sufficiently secure. In the figure, for illustrative purposes, the size of the contacts is exaggerated.

For the purposes of electronics also adhesives with electric conductivity are used. These are usually cold setting epoxy adhesives with a high content of powdered silver as the filler. The more precious the material with electric conductivity used as the filler the longer the adhesive will have good conducting properties. An example of the application of such adhesives can be the repair of damaged heating system of a car rear screen. The cost element rather precludes the use of gold or platinum, hence the use of powdered silver which, additionally, has the advantage that its oxides are also good electric conductors. Thanks to this, they retain their conductivity for a long time. Adhesives with powdered aluminium as the filler tend to lose their conductivity too fast. In electronics the advantage of adhesive bonding over soldering is that the process is cold and that the mass and dimensions of the devices concerned are less of a limiting factor. Fig. 2.5 presents the principle of the creation of a conducting bond by means of electro-conducting adhesives based on fillers with electric conductivity [2.12].

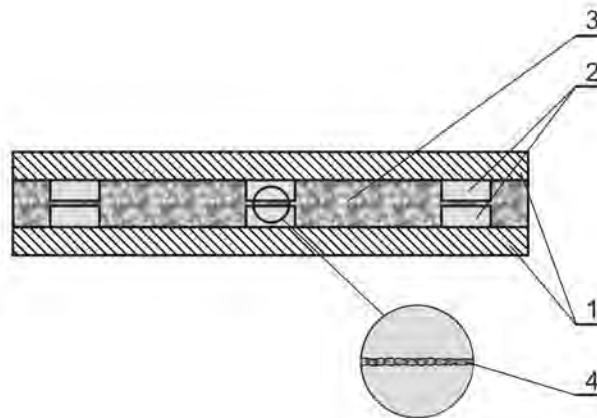

Fig. 2.5. Principle of the creation of a conducting adhesive bond using an adhesive with electric conductivity: 1 – skeleton plates, 2 – electro-conducting contacts, 3 – adhesive with electro-conducting filler, 4 – electro-conducting monolayer

In this case the feature of electric conductivity is achieved through compressing the electro-conducting monolayer between the bonded terminals (contacts). The problem in this case may be short circuits in the horizontal direction.

Recently a polymer has been discovered, with electric conductivity. It may be that there will also appear adhesives based on such materials, though it is a known fact that the possibility of using a polymer material as an adhesive is determined by many factors.

There are numerous situations where it is necessary to apply adhesives with untypical properties. At present there are companies that manufacture adhesives to order, with the properties of the products constituted so as to meet customer requirements. This concerns the resistance of the adhesives to specific environmental features, thermal conductivity, magnetic flux conductivity, colouring, possibility of machining, features such as plasticity, combustibility, and many others.

2.7. Conclusions

The technology of adhesive bonding and sealing finds more and more acceptance in the machine building industry. The very important feature of adhesives – combining the functions of bonding and sealing – causes that more and more frequently adhesives are employed in modern designs, and there is increasing confidence in adhesive bonding among design and process engineers. There are numerous examples of this situation, the most characteristic being the following:

- adhesive mounting of rolling bearings,
- adhesive mounting of gears and pulleys on shaft trunnions,
- sealing of threaded and flange-type joints,
- sealing of structures,
- adhesive bonding of frames and wall panels in containers and refrigeration structures,
- adhesive bonding of soundproofing lining materials,
- adhesive bonding of brake pads and linings,
- adhesive bonding of heating system elements,
- adhesive mounting of cowlings and mirrors,
- adhesive bonding of glass panes,
- adhesive bonding of machine control elements.

The presented brief analysis of applications and properties of some adhesive materials provides the basis for the formulation of the following general remarks and conclusions:

- the achievements of recent years in the field of chemical technology of adhesive materials create new perspectives in machine building,
- the broad possibilities of modification of physicochemical properties of adhesive materials permit the application of the technology of adhesive bonding, sealing and renovation/repair in various branches of the machine building industry,
- cold setting (during very short time) single-component adhesives permit the application of simple technology, hence adhesive bonding can be economically competitive with relation to other joining technologies,
- the use of modern renovation/rework materials permits effective repair and overhaul of many elements of machines,

- new generation of sealing materials permits a reduction in the weight of structures with simultaneous improvement of their reliability.

The presented general conclusions are only indicators of the enormous progress that has been observed in recent years in the production and application of adhesive materials. Special possibilities of further applications of such materials can be found in the machine building industry.

References

- 2.1. Cagle Ch. V.: Kleje i klejenie. WNT, Warszawa, 1997.
- 2.2. Jurkowski B., Jurkowska B.: Sporządzanie kompozycji polimerowych. Elementy teorii i praktyki. WNT, Warszawa, 1995.
- 2.3. Kuczmaszewski J.: Podstawy konstrukcyjne i technologiczne oceny wytrzymałości połączeń metali. Wydawnictwa Uczelniane PL, Lublin 1995 r.
- 2.4. Łunarski J.: Połączenia klejowe w procesach montażu. Technol. i automatyzacja montażu. 2/1994.
- 2.5. Prawdzińska L., Zygmund H.: Kleje. Informator. Wyd. III. Biuro Wydawnicze Chemia. Warszawa, 1979.
- 2.6. Raczkowski D., Stanisławski J.: Polskie kleje przemysłowe. Technologia i automatyzacja montażu 4/1998.
- 2.7. Rzymski W.M., Włóka M., Grzeźółkowska-Rosiak T.: Łączenie elastomerów z metalami. Polimery 2005, 50, nr 7-8.
- 2.8. Sękowska A., Sękowski S.: Kleje w naszym domu. WNT, Warszawa, 1991.
- 2.9. Siemaszko A., Porejko S.: Kleje naturalne i syntetyczne. PWT, Warszawa, 1961.
- 2.10. Spychaj T., Spychaj S.: Farby i kleje wodorozcieńczalne. WNT, Warszawa, 1996.
- 2.11. Szlezyngier W.: „Tworzywa sztuczne. Chemia. Technologia wytwarzania. Właściwości. Przetwórstwo. Zastosowanie”. Tom II, Wydawnictwo Oświatowe FOSZE, Rzeszów 1998.
- 2.12. Szczepański Z.: Nowe osiągnięcia w zakresie klejów dla elektroniki. Elektronika 12/97.
- 2.13. Sikora R.: Tworzywa sztuczne w naprawie maszyn. WNT, Warszawa, 1971.
- 2.14. Zaczek Z.: Studium wytrzymałości statycznej i odporności na działanie środowiska klejonych połączeń metali i laminatów szklanych. Wydawnictwo WSMW, Gdynia, 1973.

Chapter 3

Bonding operations

3.1. Typical bonding operations

Bonding operations include typical procedures that are performed in strict order and frequently have the character of autonomous operations. These are the following:

- preparation of surfaces of the elements to be bonded,
- preparation of the adhesive,
- application of the adhesive on the surfaces,
- setting or alignment (and fixing) of the elements to be bonded,
- curing (hardening) of the adhesive,
- finishing treatment of the bonds,
- inspection of the bonds effected.

Depending on the type of materials bonded, conditions of the bonding process, type and form of the adhesive, shape of the elements bonded, workshop capabilities, work involved in the individual procedures (stages) may be performed in one or several operations.

The more important principles and determinations concerning adhesive bonding can be formulated as follows [3.5, 3.10]:

- there are no all-purpose adhesives, but adhesives do differ in the degree of versatility,
- solvent adhesives are not used for bonding non-porous minerals; in some exceptional cases (e.g. rubber bonding using adhesives based on natural rubber or synthetic rubbers) the bonding proper is preceded with pre-drying of the adhesive applied on the bonded surfaces,
- it is recommended for the cured bond to have physicochemical properties similar to those of the bonded elements; this concerns especially the stiffness and the coefficient of thermal expansion,
- the strength of a bond as a whole is a function of both adhesive and cohesive strength; high strength can be attained only by bonds in which there is good adhesion between the adhesive and the surfaces, and the cohesive strength of the adhesive applied is high,
- the condition for lasting and reliable operation of an adhesive bond is the occurrence of chemical bonds between the adhesive and the substrate, therefore the key issue is the selection of the proper adhesive; Van der Waals bonds may be released as a result of water diffusion on the phase boundary,

- correct preparation of surfaces of bonded elements (apart from proper selection of adhesive) determines the effectiveness of bonding in the highest extent,
- the setting temperature of a thermosetting adhesive should be considerably lower than the softening point of the bonded materials; this is especially important when bonding polymer materials,
- the adhesive used should not be characterized by excessive chemical and thermal shrink rate,
- correct stickiness of adhesive is the condition of good wetting and, consequently, of good adhesive bond.

The technology of adhesive bonding should take into account the greatest possible number of factors characterizing the features of the structure and the operating conditions of the bond.

3.1.1. Preparation of bonded surfaces

The properties of surfaces of solid bodies depend largely on the manner of their formation (e.g. crystallization, grinding, polishing) and on the effect of the environment. Surface atoms of metals are additionally characterized by high chemical activity which influences the effect of the solids on gases, liquids or other solids remaining in phase contact with the metals. This leads to the adsorption of foreign substances, which causes a decrease of the free energy of the system. Therefore, under normal conditions surfaces are usually covered with a layer of oxides, adsorbed organic compounds and gases, and in the surface layer there occur effects resulting from the manner of its formation. The condition of the surface layer is also strongly correlated with the features of the environment in which the analysed object is located. The surface layer of metals is heterogeneous in geometrical and physicochemical sense.

Surfaces of all metals are characterized by a specific state of roughness. Even the most carefully machined surfaces have irregularities with heights of 0.01-0.1 μm , and those with rough machining – with heights of up to 200 μm . The geometric condition of the surface is related to the type of machining. Surfaces machined in the process of lathing, grinding or polishing have noticeable traces of the machining in the form of repeated irregularities.

Irrespective of those geometric effects of the work of the machine tool, in the machined material there may occur permanent changes in the surface layer, caused by physicochemical phenomena, such as e.g. friction or pitting, as a result of which the surface layer has a different structure. The condition of the surface layer is determined by the machining conditions, chemical composition of the metal, and its physicochemical properties [3.1, 3.6].

A zonal model of the structure of the surface layer, corresponding the most closely to the true structure, can be presented graphically as shown in Fig. 3.1. The

process of constitution of the interphase layer are also presented by R. Sikora in [3.18].

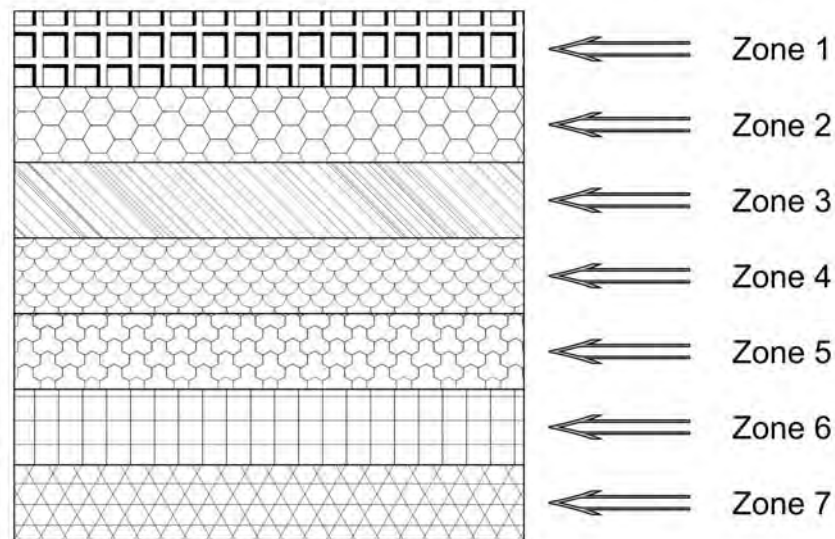

Fig. 3.1. Zonal model of the structure of the surface layer from the viewpoint of adhesive properties: Zone 1 – zone of physical adsorption, the outermost, formed as a result of adsorption of polar molecules of organic origin on metal surfaces. Zone 2 – zone of chemical adsorption, is a result of adsorption of gas molecules, reactive functional groups. These zones penetrate each other and result from adsorption of molecules with dipolar structure on the surface of a solid. Zone 3 – a layer of metal oxides. It is formed through chemical reactions of the metal. The oxide zone has a significant effect on the energy properties of the surface layer. Zone 4 – formed through damage to metal grains on the surface, caused by the action of tools on the material during machining. It is characterized by disturbed crystalline structure of the metal, the metal is deformed and textured. Zone 5 – intermediate; the texturing disappears, there is still metal with plastic deformation. Zone 6 – covers the area of elastic stress. In this zone there are the natural stresses which are caused by dislocations resulting from plastic strain. Zone 7 – represents the core material.

The difference between the structure of the surface layer, formed under specific technological conditions, and the theoretical model consists also in the fact that certain zones of the layer do not exist in a real situation, or interpenetrate each other. The thickness of the surface layer formed in the course of machining of metals may even reach 1mm.

Correct preparation of the surface of bonded elements is a necessary condition of obtaining a bond of satisfactory quality. Bond quality will be taken here to cover a set of properties of the bond, characterizing its ability to fulfil specific functions within a specific period of time.

Surface preparation should be specific to a given material and a given adhesive. The necessary condition is fulfilment of the condition $E_p > E_c$, where E_p is the free surface energy of the bonded elements, and E_c in the surface energy of liquid. The surface energy of solids is a function of the following major factors [3.10]:

$$E_p = f(S_{rz}, \sigma_w, R_r, H)$$

where: S_{rz} – actual surface and its topographic and chemical features, σ_w – natural stresses in the surface layer, R_r – tensile strength, H - hardness.

Therefore, the surface energy can be constituted through altering the stereometric features of the surface layer, as well as its physical properties.

The manner of surface preparation for adhesive bonding is different for various materials. For carbon steels there is, as a rule, surface cleaning, mechanical “development” of surface (e.g. through sand blasting or roughing up with abrasive paper, etc.) and degreasing. For alloy steels, aluminium alloys or titanium alloys appropriate chemical treatments, rinsing and drying are required to obtain good quality bonds.

The primary objectives of the preparation of surface layer of bonded elements are as follows:

- removal of inorganic contaminants from the surface,
- thorough degreasing of the surface,
- possible activation, i.e. special treatment aimed at increasing the value of free surface energy.

The more important methods of constituting the adhesive properties of the surface layer are as follows:

- mechanical methods (machining),
- chemical methods,
- activation by means of corona discharges,
- oxidation with ozone,
- activation by means of partial discharges,
- flame activation,
- activation by means of high-energy plasma, high-energy electron beam,
- activation by means of UV radiation,
- others, e.g. combinations of mechanical and chemical methods.

Machining is applied mainly in the process of preparation for joining elements of carbon structural steels. Its objective is to remove iron oxides, since they are weakly bound with the substrate, and also to partially “develop” the surface. Typical methods of machining used in processes of surface preparation for adhesive bonding include grinding, sand blasting, etc.

Additionally it should be mentioned that the adhesive properties of polymer materials can be constituted at the stage of processing, synthesis, or through the various operations to which the surface layer of materials is subjected [3.4, 3.11, 3.18, 3.19,].

The main factors affecting the adhesive properties of the surface layer of polymer materials are the temperature of the moulding composition, temperature of the mould, rate of mould filling, composition of the material, anti-adhesive admixtures, clamping pressure, conditions of product cooling, and others.

The main technologies of surface layer preparation applied for polymer materials include chemical technologies (etching, washing, etc.), energy technologies (corona discharge, flame treatment, laser treatment, etc.), mechanical technologies.

Granular tools, thanks to their common availability, ease of application without the need for additional equipment, and low costs, are convenient tools for the treatment of materials to be bonded. The application of such tools provides a directionless structure of treatment traces, which is favourable under the conditions of structural bonding.

As has been mentioned, granular tools are the most convenient tools for machining materials to be bonded or sealed. This is determined first of all by their low cost, availability, ease of application in manual operations, possibility of application under field conditions. An alternative for this type of treatment is only sand blasting, but this is a treatment which requires the application of suitable equipment, which is not easy to apply in the case of treatment of very large elements, generates noise and dust which are harmful factors.

When choosing granular tools for surface treatment, we are interested primarily in the grain size. The choice is not obvious, as we take into consideration the various physical features of structural materials, and especially their hardness or elasticity. A tool with larger grain size will be more effective in removing a layer of the material, including the physical absorption layer, but the degree of surface development will be less. Smaller grain size will provide greater degree of surface development, but from a certain limit the effectiveness of removing the physical adsorption layer will decrease.

Treatment with such tools constitutes the adhesive properties of the surface layer mainly through:

- surface development, i.e. increase in the actual surface area,
- removal of organic and inorganic contaminants from the surface,
- forming a specific topography of the surface that increases the value of free surface energy.

Some results of an experiment concerned with the effect of granular tool treatment on the energy properties of surfaces are presented in Fig. 3.2.

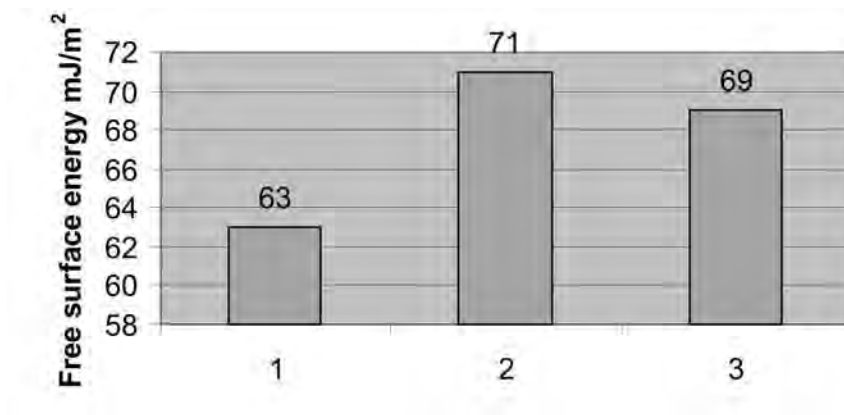

Fig. 3.2. Effects of machining with granular tools on energy properties of the surface layer of steel grade St3S (E235A acc. to ISO 630:1995): 1 – P120, 2 – P320, 3 – P500

Degreasing is a technological operation aimed at removing organic and inorganic contaminants from the surfaces on which the process of adhesive bonding is to take place. Degreasing can be performed both on raw and on treated or machines surfaces.

Chemical treatment is an effective method of constituting the adhesive properties of surface layer of structural materials. It is, however, a source of problems relating to health and safety as well as to ecological considerations. Used baths contain many chemical compounds that are dangerous for the environment, and the necessity of their treatment is frequently a major problem to manufacturing companies. Hence, wherever possible, alternatives are sought to the so-called “wet” chemical treatments.

More important treatment baths and etching process conditions [3.2, 3.16]

Aluminium and its alloys

- | | |
|--|---------------------|
| a) 1. Sulphuric acid, concentrated, H ₂ SO ₄ | 148 cm ³ |
| 2. Sodium dichromate, Na ₂ Cr ₂ O ₇ | 75 g |
| 3. Water, H ₂ O | 652 cm ³ |
| b) 1. Nitric acid, concentrated, HNO ₃ | 178 cm ³ |
| 2. Sodium fluoride, NaF | 4 g |
| 3. Water, H ₂ O | 710 cm ³ |

In cases a and b bath temperature should be 15 – 25° C, and the duration of etching approximately 2 min.

- c) 1. Sulphuric acid, concentrated, H_2SO_4 17 cm^3
 2. Potassium dichromate, $\text{K}_2\text{Cr}_2\text{O}_7$ 8 g
 3. Water, H_2O 62 cm^3
 Bath temperature 55 – 60)° C, duration of etching approx. 2 – 3 min.

- d) 1. Butyl alcohol 30 cm^3
 2. Isopropyl alcohol 30 cm^3
 3. Phosphoric acid, concentrated, H_3PO_4 10 cm^3
 4. Water, H_2O 20 cm^3
 Bath temperature 15 – 25° C, duration of etching approx. 3 – 5 min.

Copper alloys

- a) 1. Sulphuric acid, concentrated, H_2SO_4 20 cm^3
 2. Potassium dichromate, $\text{K}_2\text{Cr}_2\text{O}_7$ 8 g
 3. Water, H_2O 75 cm^3
 Bath temperature 15 – 25° C, duration of etching approx. 2 – 3 min.

- b) 1. Nitric acid, concentrated, HNO_3 30 cm^3
 2. Ferric chloride, FeCl_3 15 g
 3. Water, H_2O 200 cm^3
 Bath temperature 16 – 20° C, duration of etching approx. 2 min.

- c) 1. Hydrochloric acid, concentrated, HCl 50 cm^3
 2. Ferric chloride, FeCl_3 20 g
 3. Water, H_2O 30 cm^3
 Bath temperature 16 – 20)° C, duration of etching approx. 1 – 2 min.

Magnesium and its alloys

Usually, for magnesium and its alloys two-stage etching is recommended.

- I. 1. Liquid glass, $\text{Na}_2\text{O} \cdot n\text{SiO}_2$ 25 cm^3
 2. Sodium pyrophosphate, $\text{Na}_4\text{P}_2\text{O}_7$ 11 g
 3. Sodium hydroxide, NaOH 11 g
 4. Detergent, e.g. dish washing fluid 1 cm^3
 5. Water, H_2O , to the volume of 1000 cm^3

Bath temperature 70 – 90° C, duration of etching 10 min.

After thorough rinsing with water one of the following baths can be applied:

- II a. 1. Chromium trioxide, CrO_3 20 g
 2. Water, H_2O , to the volume of 100 cm^3

Bath temperature 65 – 70° C, duration of etching 10 min;

- IIb. 1. Sulphuric acid, 20%, H_2SO_4 100 cm³
 2. Potassium dichromate, $\text{K}_2\text{Cr}_2\text{O}_7$ to saturation
 Bath temperature 15 – 25° C, duration of etching approx. 2 – 5 min.

Chromium and chromium-plated metals

- Hydrochloric acid, concentrated, HCl 50 cm³
 Bath temperature 80 – 90° C, duration of etching 2 – 5 min.

Zinc and its alloys

1. Hydrochloric acid, HCl 10 cm³
 2. Water, H_2O 85 cm³
 Bath temperature 16 – 20° C, duration of etching approx. 1 – 2 min.

Nickel, nickel alloys and nickel-plated metals

- a) Nitric acid, HNO_3 , concentrated
 Bath temperature 16 – 20° C, duration of etching 4 – 6 s.
- b) 1. Chromium trioxide, CrO_3 15 g
 2. Hydrochloric acid, HCl, concentrated 25 cm³
 Bath temperature 16 – 20° C, duration of etching 1 min.

Titanium and its alloys

Two-stage etching is recommended.

- Ia) 1. Hydrochloric acid, HCl, concentrated 48 cm³
 2. 30% formaldehyde (formalin) 9 cm³
 3. 30% hydrogen peroxide 3 cm³
 4. Water, H_2O 50 cm³
 Bath temperature 60 – 70° C, duration of etching 10 min.

- Ib) 1. Liquid glass, $\text{Na}_2\text{O} \cdot n\text{SiO}_2$ 20 cm³
 2. Sodium pyrophosphate, $\text{Na}_4\text{P}_2\text{O}_7$ 10 g
 3. Sodium hydroxide, NaOH 12g
 4. Water, H_2O , to the volume of 1000 cm³
 Bath temperature 70 – 80° C, duration of etching 10 min.

After thorough rinsing with water the second stage of etching is applied:

- IIa) 1. Chromium trioxide, CrO_3 5 g
 2. Water, H_2O 95 cm³

Bath temperature 60 – 70° C, duration of etching 5 min.

- | | |
|---|--------------------|
| IIb) 1. Sulphuric acid, concentrated, H ₂ SO ₄ | 90 cm ³ |
| 2. Sodium dichromate, Na ₂ Cr ₂ O ₇ (saturated water solution) | 8 cm ³ |

Bath temperature 45 – 50° C, duration of etching 10 min.

Carbon steels and cast-iron

As a rule, it is sufficient to apply mechanical treatment, aimed at removing the physical adsorption layer and corrosion products, and degreasing. In special applications a bath treatment is applied:

- | | |
|---|--------------------|
| 1. Sulphuric acid, concentrated, H ₂ SO ₄ | 25 cm ³ |
| 2. Potassium dichromate, Na ₂ Cr ₂ O ₇ | 7 g |
| 3. Water, H ₂ O | 60 cm ³ |

Bath temperature 55 – 65° C, duration of etching 15 – 25 min.

Stainless steels

- | | |
|--|---------------------|
| a) 1. Hydrochloric acid, HCl, concentrated | 46 cm ³ |
| 2. 30% formaldehyde (formalin) | 8 cm ³ |
| 3. 30% hydrogen peroxide | 2 cm ³ |
| 4. Water, H ₂ O | 425 cm ³ |

Bath temperature 55 – 65° C, duration of etching 5 – 10 min.

- | | |
|--|---------------------|
| b) 1. Sulphuric acid, concentrated, H ₂ SO ₄ | 80 cm ³ |
| 2. Oxalic acid, C ₂ O ₄ H ₂ | 100 g |
| 3. Water, H ₂ O | 840 cm ³ |

Bath temperature 55 – 65° C, duration of etching approx. 25 – 30 min.

- | | |
|--|---------------------|
| c) 1. Sulphuric acid, concentrated, H ₂ SO ₄ | 250 cm ³ |
| 2. Hydrochloric acid, HCl | 250 cm ³ |
| 3. Water, H ₂ O | 500 cm ³ |

Bath temperature 35 – 45° C, duration of etching 1 – 2 min.

It is a rule that after etching objects should be carefully rinsed, then dried, preferably at approximately 60° C. After that the surfaces should either be coated with special preparations protecting against oxidation or additionally activating the surfaces in terms of energy, or proceed immediately with the bonding.

A relatively new method of constituting the properties of the surface layer is ozone treatment. Ozone is a strongly reactive gas, and causes rapid oxidation of the material. The result of that is the formation of radicals of peroxides reacting with the material, which causes the appearance of numerous new polar groups.

A similar effect is produced by the promoters of adhesion. They act in a “coupling” manner, diffuse into the material, and create chemical bonds.

Basing on experience acquired so far, the most appropriate is energy analysis of these complex inter-phase phenomena.

It has been known for a long time that the effectiveness of bonding and sealing depends to the greatest extent on the method of preparation of the surface layer of the material, assuming, of course, that the adhesive has been chosen correctly. The essence of correct preparation of the surface layer can be reduced to suitable constitution of its adhesive properties. It is no accident that we refer the preparation of materials for bonding and sealing to the surface layer and not to the surface, as the value of free surface energy is determined also by physical phenomena and properties of material located close to the actual surface in its geometric sense. To constitute the adhesive properties is primarily to constitute the energy properties of the surface layer. We say „primarily”, as we cannot totally leave out the phenomenon of mechanical anchorage of the adhesive, varnish, paint or sealant in the micro-pores of the bonded elements, i.e. mechanical adhesion.

As a rule, in operations of adhesive bonding and sealing we aim at obtaining the highest possible strength of the bond produced. An important indicator of the correctness of surface preparation for bonding is free surface energy. Free surface energy of structural materials depends on a number of factors, including the stereometric structure of the surface, certain physical properties of materials, and also the properties of the physical adsorption zone on the surface of the solid. Under natural conditions, the physical adsorption layer occurs at all times. The studies performed were concerned primarily with the conditions of bonding and sealing. Those, therefore, are typical conditions that can be found in a production plant, even with the assumption that bonding is performed at a dedicated workstation with strictly observed technological discipline. Bonding and sealing can also be performed under field conditions, as well as proving ground or marine conditions.

In recent years, in works of cognitive character and concerned with the phenomenon of adhesions, considerable attention is devoted to the dispersion and polar components of free surface energy. These are most frequently determined according to the Fowkes method [3.3, 3.7, 3.8, 3.18, 3.19]. The division of effects of adhesive character into dispersive and polar is fairly convenient and permits a fuller estimation of the adhesive properties of solids, and thus facilitates the prediction of the effectiveness of bonding and sealing. In the studies performed, apart from the work of adhesion in the system of studied material-distilled water, also determined was the work adhesion in the system of studied material-diiodomethane (CH_2I_2), which, as a result, permitted the determination of the relation between the dispersion and polar components for the tested structural materials after various technologies of their surface layer preparation.

For the realization of the studies, a special measurement station was designed and made, as schematically presented in Fig. 3.3.

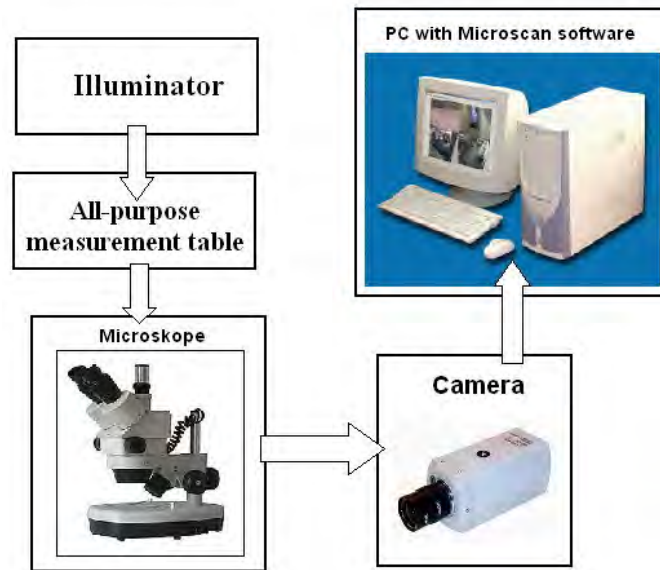

Fig. 3.3. Schematic of the measurement station

The measurement station permits the analysis of objects, phenomena and processes recorded in the form of images. In the experiment described further on, the station was used for wetting angle measurements.

Every treatment constitutes a certain state of the surface layer [3.1, 3.9, 3.13, 3.14]. The important thing is for the features of the constituted surface layer to be conducive to the attainment of the most favourable features of adhesive bonds, especially in the technologies of bonding and sealing. As follows from the definition of free surface energy, from the viewpoint of requirements posed for adhesive bonds the most favourable is that technology of surface layer preparation which ensures the highest value of that energy. There is, however, one important problem. The problem is the strength of the surface layer itself. It turns out that the surface layer may be characterized by good energy properties, but after bonding the strength of the adhesive bond may be low due to low strength of the surface layers of the materials bonded. Therefore, not always there is a directly proportional relation between the value of free surface energy of a solid and a liquid and the strength of adhesive bonds, in a situation when the same liquid is in cured or hardened state.

From the research point of view the problem of constituting the dispersion and polar components of free surface energy is also interesting. This is especially important in the prediction of the physical properties (long-term strength properties in particular) of polar and non-polar materials.

From the viewpoint of assessment of the adhesive properties of the surface layer it is convenient to use free surface energy as a measure for the estimation of technologies aimed at the constitution of such properties.

Adhesive properties of structural materials can be analysed at various levels of structure: atomic, molecular, super-molecular, and macroscopic. The major parameters of structure considered at the atomic, molecular and super-molecular levels, as well as factors affecting the adhesive properties of the surface layer on the macroscopic level, have been presented in Chapter 1.

Especially interesting is the possibility of constituting adhesive properties at the macroscopic level, i.e. at the stage of particular technological processes applied to ready products, as this has the greatest practical significance. The processes of treatment or machining permit the obtainment of the following major effects related to the adhesive properties of the surface layer:

- surface development,
- creation of functional groups,
- intensification of the processes of wetting,
- increase of polarity,
- generation of energy-active micro-defects,
- removal of gas and water molecules,
- super-molecular ordering of the structure (in the case of polymer materials),
- catalytic effect on the processes of adsorption,
- appearance of free radicals,

The effects of the processes of treatment or machining, i.e. of processes taking place on the macroscopic level, may generate effects taking place on various levels. This is related, among other things, with other phenomena of mechanical-chemical character that occur in the course of the processes of treatment and machining.

Adhesive properties of the surface layer are, therefore, a derivative of numerous phenomena and factors, not just those that take place during the processes of synthesis, processing, or machining. Other factors related with the adhesive properties of the surface layer of structural materials are presented in Fig. 3.4.

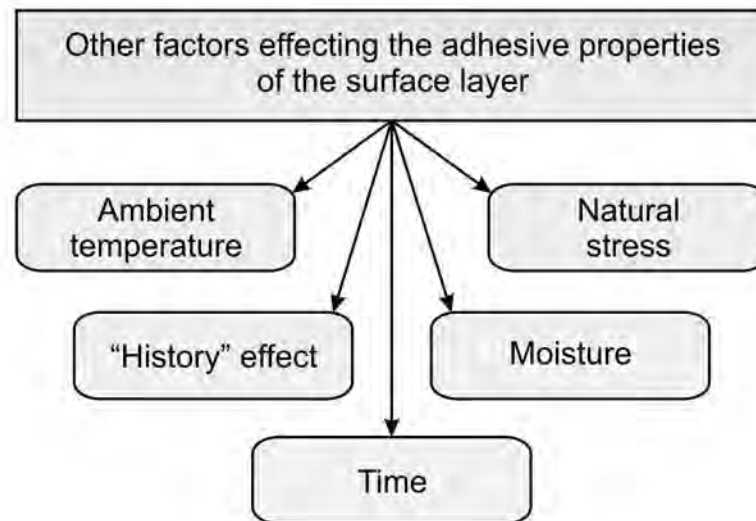

Fig. 3.4. Other factors affecting the adhesive properties of the surface layer of polymer materials

The specific nature of studying the free surface energy requires very careful statistical processing of collected data. For this purpose parametric tests of significance were employed, used for comparison of mean values of a tested feature in two general populations. The tests take into account error of the first kind, consisting in the rejection of the tested hypothesis in the case when it is true. Error of the first kind, called the level of significance, was adopted at the level of $\alpha = 0.05$. In view of the fact that the samples for which the tests were performed were composed of 10 – 30 elements, they should be considered to be small samples.

With the adopted level of significance α the following hypothesis was subjected to verification: $H_0 : m_1 = m_2$ (mean values of feature X in both populations are identical), as opposed to the hypothesis: $H_1 : m_1 \neq m_2$ (mean values of feature X in both populations are not identical). Also verified was the hypothesis of the equality of variance. Depending on the effects of the verification, a suitable model was selected for the comparison of the mean values.

Fig. 3.5 presents selected results of the experiment concerned with the determination of the value of free surface energy of an aluminium alloy after the application of various methods of surface preparation.

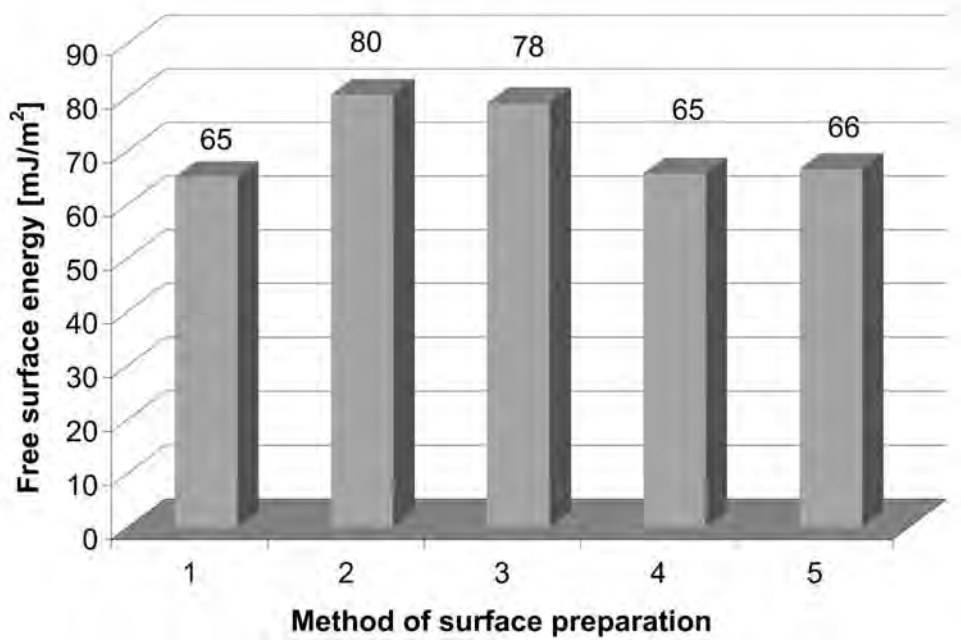

Fig. 3.5. Value of free surface energy for PA7 alloy (EN AW 2024 acc. to PN-EN 573-3:1998): 1 – after treatment with abrasive granular tool P320, 2 – after anode oxidation, 3 – after anode oxidation and degreasing, 4 – after treatment with abrasive granular tool P320 and degreasing, 5 – after treatment with abrasive granular tool P320 and rinsing with mains water [3.12]

It should be noted that the total value of free surface energy γ_s is a sum of the dispersion and polar components. More information of this is given in Chapter 8. Depending on the applied method of surface preparation, there are changes not only in the total value of free surface energy, but the components of the energy tend to change to different extents. This is of significant importance for the constitution of the adhesive properties.

Table 3.1 presents the results of determinations of free surface energy for the PA1 alloy after the application of various methods of surface preparation.

Table 3.1. Free surface energy of PA1 aluminium alloy (EN-AW-3103 acc. to PN-EN573-3:1998)

Item	Method of surface preparation	Wetting angle θ [°]		Free surface energy γ_s [mJ/m ²]		
		H ₂ O	CH ₂ J ₂	γ_s^d	γ_s^p	γ_s
1	Treatment with P320	73,2	31,0	38,6	6,7	45,3
2	Treatment with P320 + degreasing	75,8	28,5	40,7	4,7	45,4
3	Treatment with P320 + water	80,8	29,8	41,5	2,9	44,4
4	Anodising	19,9	28,0	30,2	39,6	69,8

The manner of surface preparation has a significant effect on the strength of the effected adhesive bonds. The results of comparative studies are presented figures 3.6 - 3.14 [12].

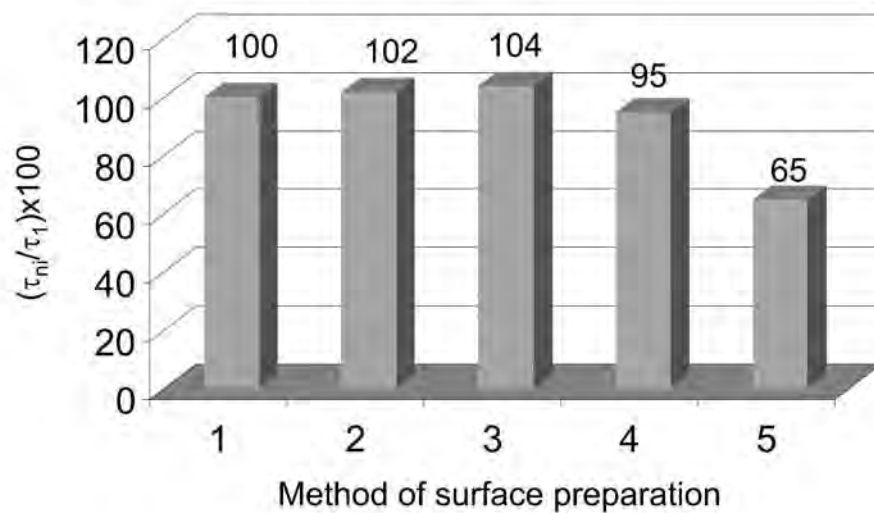

Fig. 3.6. Ratio of destructive stress τ_{ni} of a lap joint after i -th method of surface preparation to destructive stress τ_1 after treatment with granular tool P320 for adhesive joints of PA7 (EN AW 2024 acc. to PN-EN 573-3:1998) bonded with the adhesive E57/PAC/10:8: 1 – after treatment with the abrasive granular tool P320, 2 – after anode oxidation, 3 – after anode oxidation and degreasing, 4 – after treatment with abrasive granular tool P320 and degreasing, 5 – after treatment with abrasive granular tool P320 and rinsing with mains water; curing at ambient temperature [3.12]

Table 3.2. presents the values of free surface energy and its components for zinc coated sheets after about a year of seasoning under laboratory conditions (no additional treatment). It is worth noting the differences in the values of the polar component for sheets zinc coated with the electrolytic and immersion methods.

Table 3.2. Values of wetting angle and free surface energy and its components for zinc coated sheets [3.15, 3.16]

Item	Type of zinc coated sheets	Wetting angle θ [°]		Free surface energy and its components [mJ/m ²]		
		θ_w	θ_d	γ_s	γ_s^p	γ_s^d
1	Zinc coated sheets (electrolytic method)	40,0	28,1	60,4	27,7	32,7
2	Zinc coated sheets (immersion method)	73,8	35,7	43,2	6,6	36,6

In the case of aluminium alloys there is a very distinct positive effect of the technology of anode oxidation on their adhesive properties. Application of that technology causes observable increase both in the value of free surface energy and in strength. Also notable is the negative effect of rinsing with mains water on the strength of the bonds formed, with a relatively slight effect of that operation on the value of free surface energy. More important results are presented in figures 3.7 and 3.8. After anode oxidation an increase of about 40% was observed in the strength of the bonds, as compared to the strength obtained after the application of treatment with the abrasive granular tool P320.

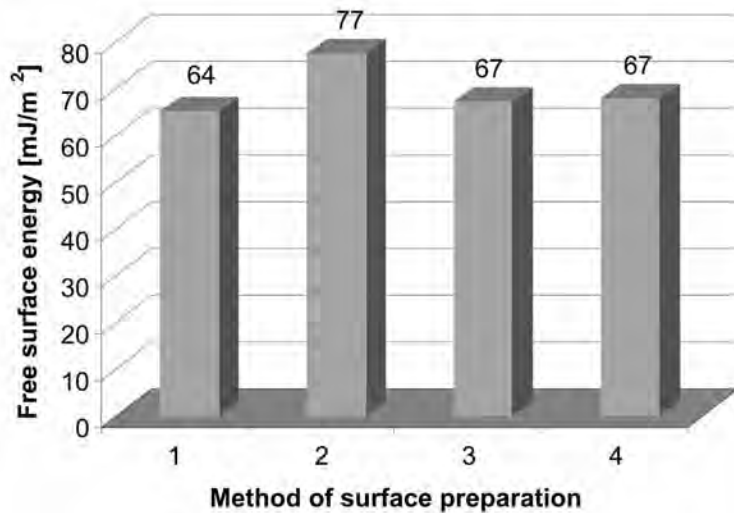

Fig. 3.7. Value of free surface energy for PA1 aluminium alloy (EN-AW-3103 acc. to PN-EN573-3:1998): 1 – after treatment with the abrasive granular tool P320, 2 – after anode oxidation, 3 – after treatment with the abrasive granular tool P320 and degreasing, 4 – after treatment with abrasive granular tool P320 and rinsing with mains water [3.12]

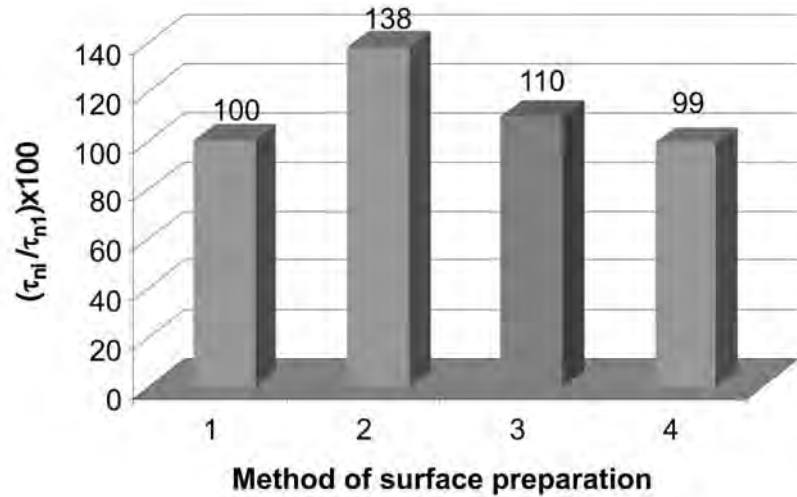

Fig. 3.8. Ratio of destructive stress τ_{ni} of a lap joint after i -th method of surface preparation to destructive stress τ_1 after treatment with the abrasive granular tool P320 for adhesive joints of PA1 (EN-AW-3103 acc. to PN-EN573-3:1998) bonded with the adhesive E57/PAC/10:8: 1 – after treatment with the abrasive granular tool P320, 2 – after anode oxidation, 3 – after treatment with the abrasive granular tool P320 and degreasing, 4 – after treatment with the abrasive granular tool P320 and rinsing with mains water; curing at ambient temperature [3.12]

It is interesting to compare the relation between the value of free surface energy and the shearing stress of adhesive bonds for steel grade St3S (E235A acc. to ISO 630:1995) (Fig. 3.9, Fig. 3.10). After rinsing with mains water the value of free surface energy increase, while the strength of the bonds strongly decreases. The environment of mains water accelerates the process of surface oxidation, and iron oxides are weakly bound with the surface, hence the rapid decrease in strength. Also, a positive effect of degreasing can be observed. Although it has no greater effect on the value of free surface energy, but it does cause a notable increase in the strength of the bonds.

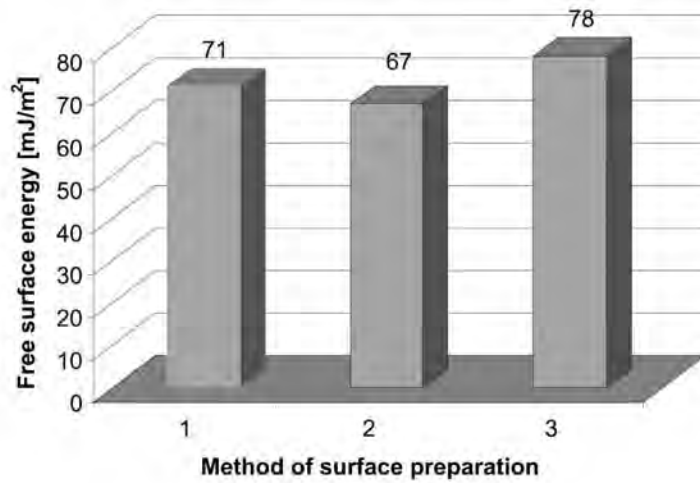

Fig. 3.9. Value of free surface energy for steel grade St3S (E235A acc. to ISO 630:1995): 1 – after treatment with the abrasive granular tool P320, 2 – after treatment with the abrasive granular tool P320 and degreasing with the Loctite7061 preparation, 3 – after treatment with the abrasive granular tool P320 and rinsing with mains water [3.12]

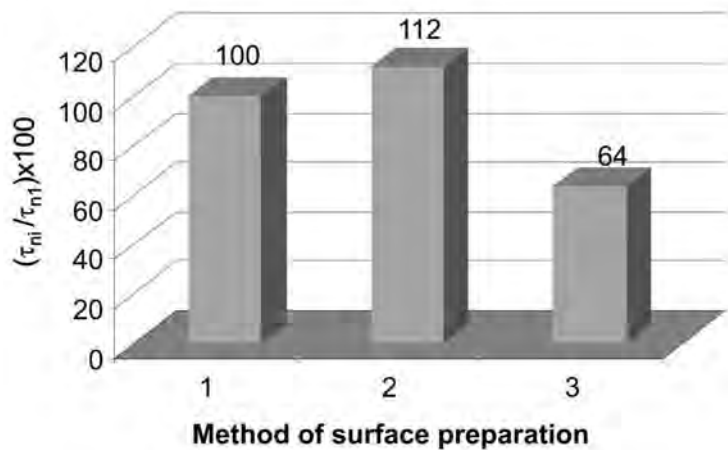

Fig. 3.10. Ratio of destructive stress τ_{ni} of lap joint after i -th method of surface preparation to destructive stress τ_1 after treatment with the abrasive granular tool P320 for adhesive joints of St3S steel (E235A acc. to ISO 630:1995) bonded with adhesive E57/PAC:10:8: 1 – after treatment with the abrasive granular tool P320, 2 – after treatment with the abrasive granular tool P320 and degreasing with the Loctite7061 preparation, 3 – after treatment with the abrasive granular tool P320 and rinsing with mains water; curing at ambient temperature [3.12]

Rinsing with mains water does not display such a negative effect on the strength of adhesive joints in the case of stainless steels (Fig. 3.11, Fig. 3.12). In this case that operation has no greater effect on the value of free surface energy nor on the strength of the bonds.

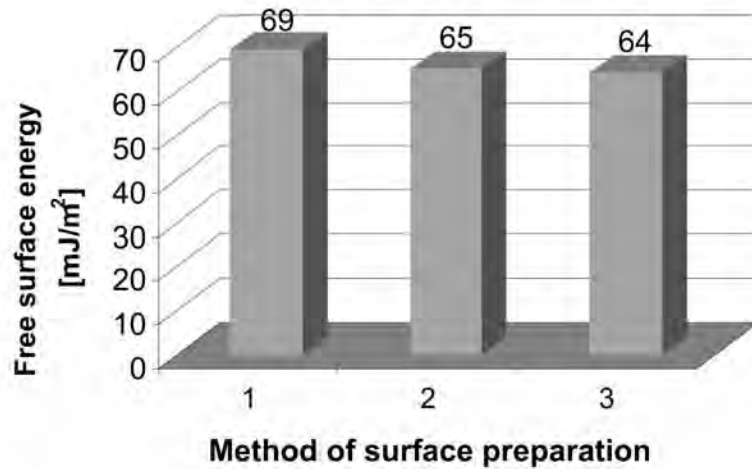

Fig. 3.11. Value of free surface energy for stainless steel grade 1H18N9TA (X6CrNiTi18-10-2 acc. to PN-EN 100881): 1 – after treatment with the abrasive granular tool P320, 2 – after treatment with the abrasive granular tool P320 and degreasing with the Loctite7061 preparation, 3 – after treatment with the abrasive granular tool P320 and rinsing with mains water [3.12]

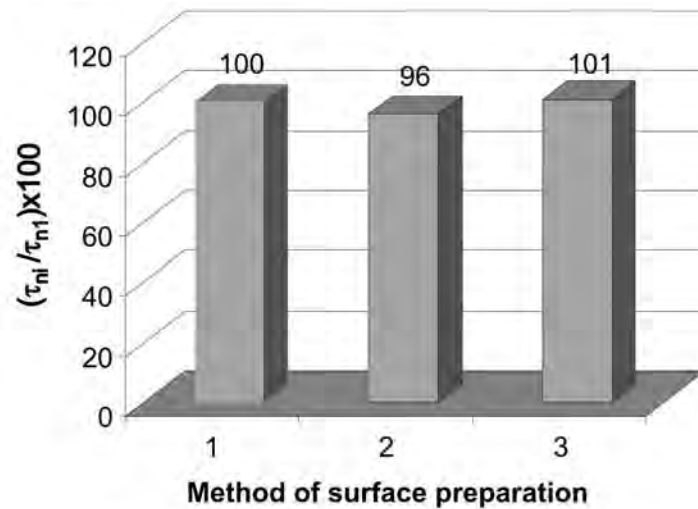

Fig. 3.12. Ratio of destructive stress τ_{ni} of a lap joint after i -th method of surface preparation to destructive stress τ_1 after treatment with the abrasive granular tool P320 for adhesive joints of stainless steel grade 1H18N9TA (X6CrNiTi18-10-2 acc. to PN-EN 100881) bonded with adhesive E57/PAC:10:8: 1 – after treatment with the abrasive granular tool P320, 2 – after treatment with the abrasive granular tool P320 and degreasing with the Loctite7061 preparation, 3 – after treatment with the abrasive granular tool P320 and rinsing with mains water; curing at ambient temperature [3.12]

In the case of the WT10 titanium alloy (Fig. 3.13, Fig. 3.14) there is a distinct positive effect of degreasing on the strength of bonds. It is interesting to note that the WT10 alloy in untreated state displays a fairly high value of free surface energy, while its adhesive joints have very low strength characteristics. This indicates the existence of a physical adsorption layer that has a strong weakening effect on adhesive bonds.

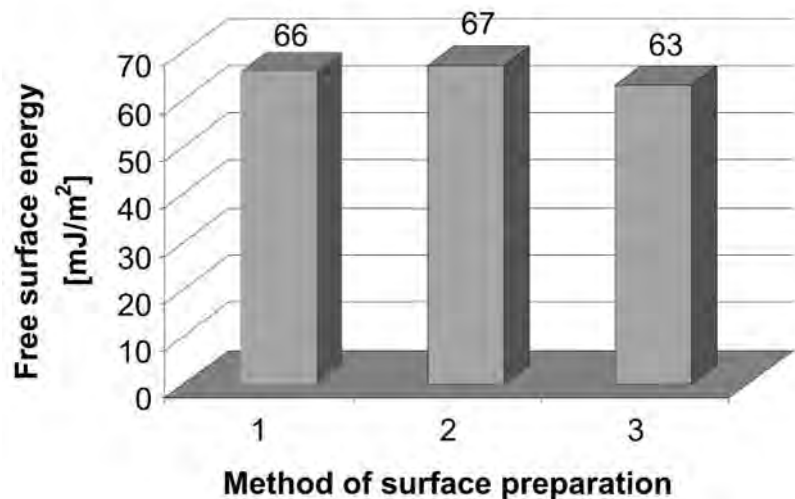

Fig. 3.13. Value of free surface energy for titanium alloy grade WT10: 1 – after treatment with the abrasive granular tool P320, 2 – after treatment with the abrasive granular tool P320 and degreasing with the Loctite7061 preparation, 3 – in untreated state

It is generally accepted that dominant technologies in the preparation of surfaces of structural materials for adhesive bonding and sealing are chemical technologies (including also conventional washing with classic agents emulsifying fats and greases). The experiments carried out support the thesis of significant effect of treatment with granular tools on the value of free surface energy. The experiments show that treatment with granular tools increases the value of free surface energy. For most structural materials there is also an increase in the value of the bond breaking force. Fig. 3.15 presents the results of a relevant experiment.

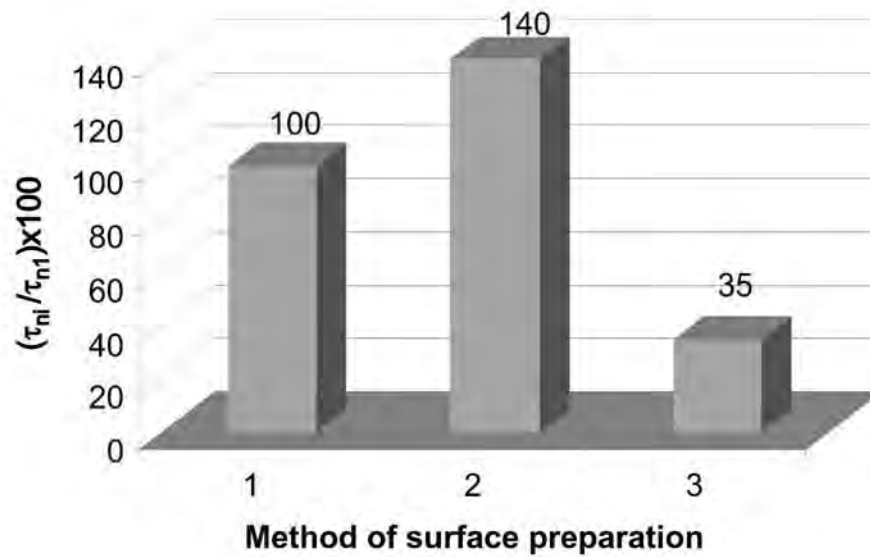

Fig. 3.14. Ratio of destructive stress τ_{ni} of lap joint after i -th method of surface preparation to destructive stress τ_1 after treatment with the abrasive granular tool P320 for adhesive joints of WT10 titanium alloy bonded with adhesive E57/PAC/10:8, with curing at ambient temperature: 1 – after treatment with the abrasive granular tool P320, 2 – after treatment with the abrasive granular tool P320 and degreasing with the Loctite7061 preparation, 3 – in untreated state [3.12]

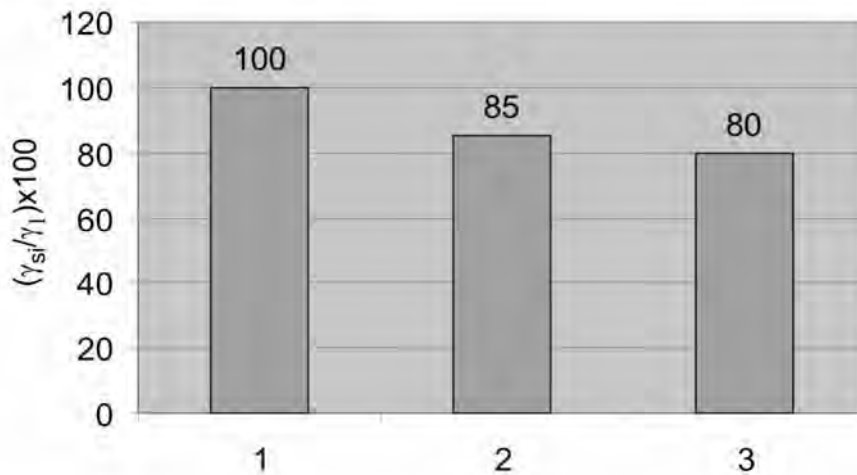

Fig. 3.15. Relative value of free surface energy for PA1 aluminium alloy (EN-AW-3103 acc. to PN-EN573-3:1998) after treatment with abrasive granular tool: 1 – P320, 2 – P120, 3 – P500.

Degreasing is a technological operation aimed at removing greases and other organic contaminants from surfaces to be bonded or sealed. Fig. 3.16 presents certain results of an experiment concerned with the effect of degreasing on the strength of adhesive joints of metals.

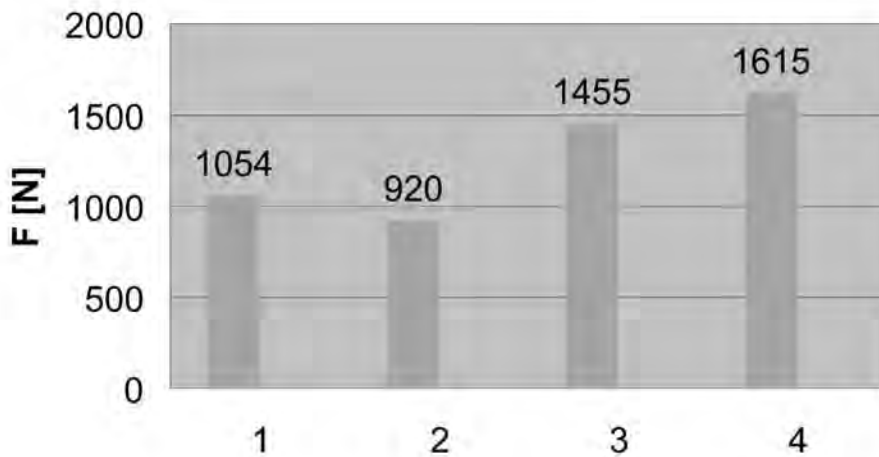

Fig. 3.16. Value of force breaking a lap adhesive joint: 1 – PA7 alloy (EN AW 2024 acc. to PN-EN 573-3:1998) after treatment with abrasive granular tool P320, 2 – PA7 alloy (EN AW 2024 acc. to PN-EN 573-3:1998) after treatment with abrasive granular tool P320 and degreasing with the Loctite 7061 preparation, 3- St3S steel (E235A acc. to ISO 630:1995) after treatment with abrasive granular tool P320, 4 - St3S steel (E235A acc. to ISO 630:1995) after treatment with abrasive granular tool P320 and degreasing with Loctite 7061; adhesive E57/PAC/10:8, curing at ambient temperature, joint dimensions acc. To PN-69/C - 89300

The obtained results of experiments permit the formulation of the statement that an appropriate process of surface preparation and its correct performance may significantly facilitate increase in the strength of adhesive joint as well as the constitution of specific energy properties of the surface layer. The ability of controlling the energy status of the surface layer is important not only in the processes of adhesive bonding or sealing, but also in all situations where there occurs a flow of a medium (pipes, hoses), or tribological phenomena (plain bearings, sleeves) and other.

The performed analysis and studies on the effect of selected technologies of surface layer preparation, apart from the cognitive effects, permit the formulation of some important conclusions of detail character, as follows:

1. Treatment by means of granular tools has a favourable effect on the adhesive properties of all materials.
2. The most versatile granular tool is that with grain size within P300.

3. Etching is a process that increases the free surface energy of the surface layer, but the scope of application of the process or surface layer preparation is limited to selected metals only.
4. Degreasing permits the removal of contaminants adsorbed on the surface layer. The studies performed indicate the necessity of correct selection of degreasing preparation.
5. In the case of aluminium alloys very good effects are obtained through the application of anode oxidation of the surface layer. The operation “develops the surface” and the oxides formed are strongly bound with the substrate.
6. For aluminium alloys rinsing with water is not recommended as an element of the technology of surface preparation for adhesive bonding. After rinsing with mains water a notable decrease is observed in the strength of adhesive joints. A similar effect is observed in the case of structural steels of regular grades.
7. Stainless steels are less susceptible to oxidation, hence rinsing with mains water has no significant effect on the energy properties of the surface nor on the strength of adhesive bonds.
8. Worthy of emphasis is the highly important conclusion that free surface energy cannot be a measure of the correctness of surface preparation of all materials for adhesive bonding. In the case of materials whose oxides are weakly bound with the substrate (e.g. steels), even though the process of oxidation increases their value of free surface energy the strength of adhesive bonds of such materials decreases.

3.1.2. Choice of adhesive

There is an extensive array of commercial adhesives for metal bonding on the market. In spite of that, we do sometimes decide to prepare our own modification of an adhesive. A good choice of adhesive for a specific structure and defined conditions of its operation is the condition of effective adhesive bonding.

Major factors affecting the choice of adhesive are as follows:

- type of materials to be joined,
- mechanical loads in the process of operation,
- thermal loads in the process of operation,
- environment in which the bond will be operated,
- planned duration of operation (service life),
- type of protection of the bond area against environmental effects.

At present there many possibilities of modifying the properties of adhesives and one can assume that there is a possibility of preparing a special adhesive for every individual and specific case. Adhesive bonding is a process of too great a complexity to permit the formulation of simple and universal principles. However, we can provide several hints and indications, important from the viewpoint of the effects of metal bonding.

1. Nonporous materials (e.g. metals) are not bonded with solvent adhesives.

2. Materials containing non-polar molecules are bonded with the help of adhesives with non-polar molecules, while materials containing polar molecules are bonded with adhesives containing primarily polar molecules.
3. When cured (hardened), the adhesive should have properties similar to those of the materials bonded. This concerns mainly such features as the thermal expansion coefficient, also stiffness or rigidity, though in practice it is not easy to achieve, especially when bonding metals.
4. The most universal are adhesives containing in their structures various functional groups; chemical bonds between the adhesive and the material bonded are the condition of high strength of the bond.
5. For metal bonding it is best to choose adhesives characterized by the lowest possible hygroscopicity.
6. For bonding metal structures that are important from the viewpoint of safety it is best to choose adhesives with the lowest possible rates of chemical and thermal shrink of curing.
7. In structures that are subject to machining after adhesive bonding, care must be taken that the adhesive used just be suitable for machining after curing; the workability of adhesives can be improved through, among other things, the addition of suitable fillers.
8. Structures that are to be subjected to variable loads in operation should be joined by means of adhesives with suitable flexibility when cured.
9. Adhesives used to effect bonds that are to be operated in environments with oils and greases should be characterized with resistance to the effect of such agents.

It should also be mentioned that sometimes adhesives are used in special structures and for special applications, e.g. adhesives for spacecraft structures, adhesives conducting electric currents, adhesives conducting magnetic fluxes, etc. In such cases adhesives are composed specially for a given application.

3.1.3. Preparation of adhesives

Preparation of adhesives is an important element of the technology of adhesive bonding. It frequently requires from the workers a high level of skills and strict observance of technological discipline. This is true especially in the case of modified chemically-cured adhesives. The more important steps in the process of adhesive preparation (dependent on the form of the adhesive) are the following:

- dosage of components,
- mixing of components,
- dissolving of adhesives in the form of solids,
- cutting and activation of adhesive films,
- de-aggregation of powdered adhesives,
- preheating of solid adhesives.

Most commonly used are single-component adhesives, commercially available in ready-to-use form, and that is the direction adopted by the adhesive-producing industry. Such adhesives are quick-setting anaerobic assembly adhesives. Also available in ready-to-use form are many solvent adhesives, especially those for building construction and for the leather industry. Frequently used in the machine building industry are chemically-setting adhesives, where immediately before application it is necessary to mix the main component (so-called “base” component) with the curing agent. The main component is often supplied as ready-to-use, but sometimes there is a need to add certain modifying components, such as fillers, colouring additives, antipyrenes, etc. In such situations we encounter the need for dosage of components. Adhesives confectioned in small containers are frequently provided with dosage fittings (for the base and the curing agent), but in the case of industrial applications, when larger amounts of adhesives have to be prepared, it is necessary to correctly measure out appropriate quantities of components. In the case of chemo-setting adhesives, as a rule the curing agent should be added in quantities close to stoichiometric. Too large a quantity of the hardener will cause that some of it may remain unbound in the structure of the base component (most frequently a resin), while its deficiency will cause that in the structure of the cured adhesive there may occur „thin spots”, i.e. areas with insufficient hardness or excessive flexibility. Stoichiometric quantity of the curing agent is usually given in mass units, hence the components of an adhesive are usually weight out in appropriate containers.

Once the components have been correctly prepared, the next step is their mixing. This seemingly simple operation is a highly important and responsible element of the operation of adhesive bonding. Especially important are the following elements:

- thorough and homogeneous mixing of the components,
- care to prevent the formation of air bubbles in the structure of the adhesive during the mixing,
- time elapsing from the moment of joining the base component with the hardener; after a certain period of time the stickiness of the adhesive increases, the process of wetting becomes more and more difficult, and the adhesive loses its bonding properties.

Once the adhesive is cured, air bubbles left in its structure become focus points for stresses. In some cases they are located in the zone adjacent to the surface of the materials bonded and then they may join with air bubbles in micro-irregularities of the surfaces, creating bond-defect areas that may constitute a hazard to the load capacity of the structure.

Adhesives in the form of a solid need to be dissolved with a suitable solvent or melted down at elevated temperature. Hot-melt adhesives have to be used quickly, as they are characterized by short “life-time”, i.e. time during which they can be applied. The stickiness of such adhesives increases fast with decreasing temperature. Therefore, such adhesives are used either in individual production or

else require the application of specialized equipment for continuous maintaining of high temperature. This latter solution is economically justified only in large-scale production programmes.

For ecological reasons, the situation is the most favourable when the solvent used in adhesive bonding is water, and such is the current trend in the production of adhesives and solvent paints. The amount of solvent to be used is determined by the required level of stickiness, and that is related to the conditions of bonding. Adhesive bonding on vertical and steeply inclined walls requires the application of adhesives with increased stickiness.

Adhesives in the form of films need to be cut into suitable strips, moreover, in its surface layer the adhesive needs to be „activated” in the process of so-called „freshening-up” i.e. rubbing with a solvent. Such adhesives are applied in special operations, and their curing requires the application of heating equipment and special tooling for exerting the required clamping pressures.

Adhesives in the form of powder are mechanically or electrostatically sprayed onto surfaces preheated to a temperature above the melting point of the adhesive applied. Application of such adhesives should be preceded with a check for the presence of aggregates - if aggregates are detected the adhesive powder should be subjected to de-aggregation before application. Such adhesives are applied for bonding complex structures, with atypical shapes, where application of adhesives with other methods would be difficult.

In multi-component adhesives, most frequently chemo-setting, the dosage of components and their proper mixing are highly important. In series production the functions of dosage and mixing are realized in a continuous manner, most often by means of mixing equipment provided with suitable metering units. Fig. 3.17 presents schematically the major operations involved in the preparation of adhesives for application.

In the selection of a suitable type of equipment a significant role is played by such factors as the physical parameters of the adhesive (especially stickiness), the dimensions and location of the bonded surface, parameters of curing, and other factors related to the specific design of the structure.

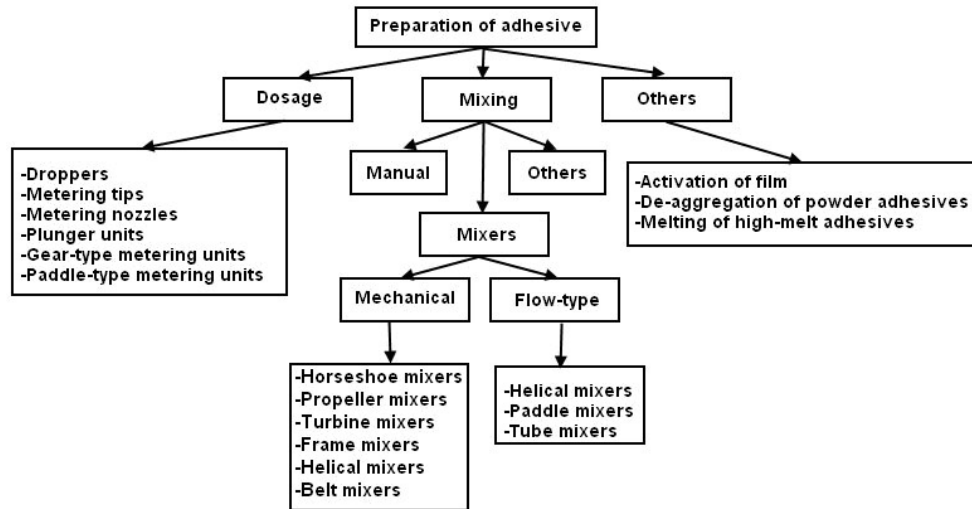

Fig. 3.17. Schematic presentation of equipment and major operations involved in the preparation of adhesives for application

The properties of the adhesive applied in a specific case, next to the mechanical and physical properties of the elements bonded, the shape and dimensions of the bond and its manner of loading, and the manner of surface preparation for the bonding, have a significant effect on the strength of the adhesive joint.

3.1.4. Application of adhesive

Properly prepared adhesive should be evenly and rapidly applied on the bonded surfaces. The amount of adhesive applied on the surfaces is very important. Too thick a layer applied will cause seepage of the adhesive, but experiments have shown that there is a range of adhesive layer thickness (approx. 0.05mm–0.15mm) above which the strength of an adhesive bond decreases. Generally it can be stated that the thickness of the layer of adhesive should be as low as possible, but sufficient for full wetting of the surface in the macroscopic sense.

The major methods of adhesive application on surfaces are the following:

- manual (brush, spatula or putty knife, rollers),
- spraying (pneumatic, hydrodynamic, flame),
- immersion (single- and two-roller, curtain),
- high-temperature,
- fluidization,
- electrostatic.

Fig. 3.18 presents schematically typical methods of application of adhesives.

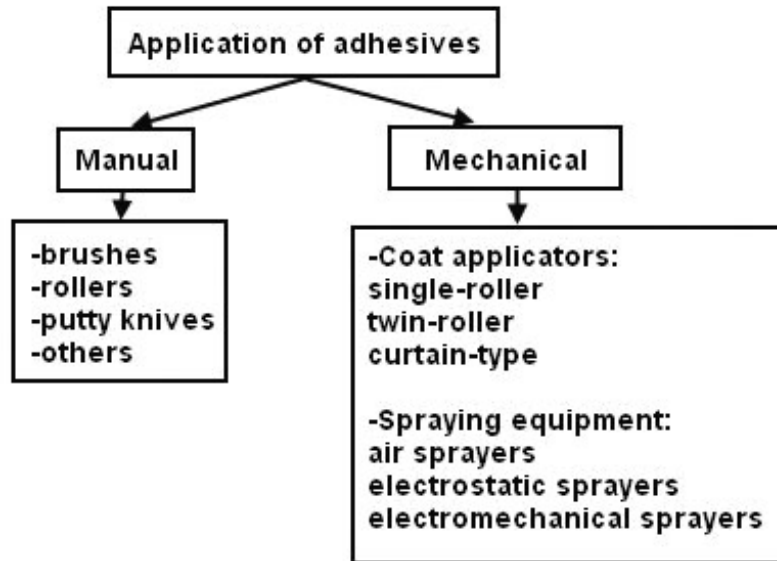

Fig. 3.18. Schematic presentation of methods used in the operation of application of adhesives

The issue of equipment for adhesive application onto surfaces bonded is presented in greater detail in Chapter 6.

3.1.5. Curing of adhesive

Adhesives can be cold- or hot-setting. Adhesive bonding can also take place at contact pressure or under increased pressure. Adhesives characterized by low chemical and thermal shrink rates are cured at contact pressure. If the curing shrink rate is high (up to several percent), then clamping pressure is applied that usually does not exceed 2 MPa [3.2].

Typical equipment for the application of clamping pressure and required process temperature is presented schematically in Fig. 3.19.

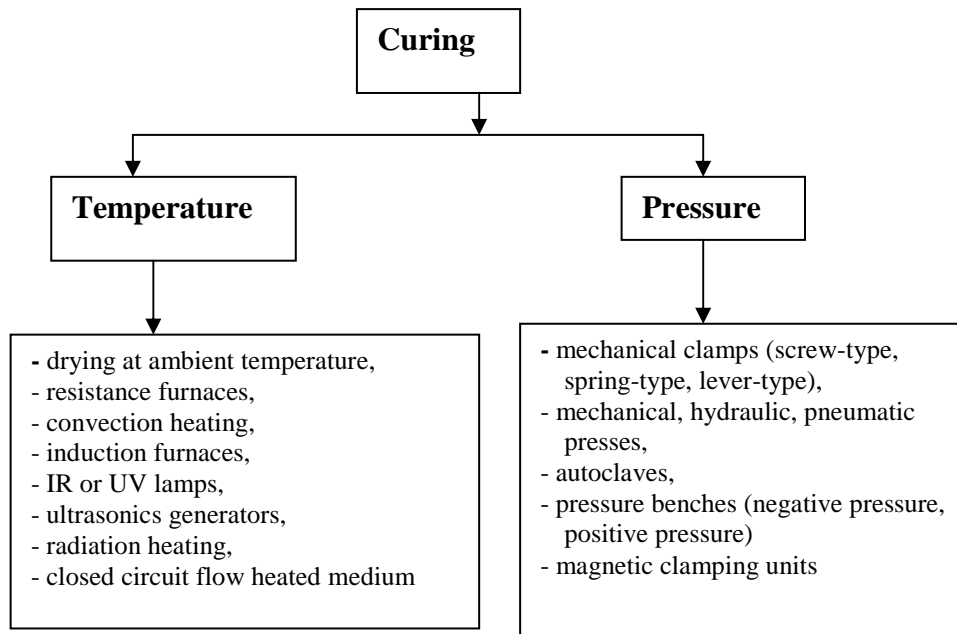

Fig. 3.19. Typical equipment used for application of pressure and increased temperature in the process of adhesive curing

Also, in the process of curing the choice of equipment to be used will be determined, among other things, by the design of the elements bonded, the dimensions and form of the structure, as well as by the physical properties of the adhesive and the materials bonded.

3.1.6. Setting (fixing) of bonded elements

In the process of adhesive bonding the elements joined are divided by a thin layer of adhesive in liquid form. Positive alignment of one element with relation to the other must, therefore, be realized with the help of appropriate fixing elements. It should also be kept in mind that as a rule the elements subjected to adhesive bonding are thin-wall, i.e. characterized by low rigidity. For this reason the fixing and mounting elements cannot be of point type. As a rule, the fixing or supporting elements should be „negatives” of the bonded elements, and the pressure applied should be flexible and distributed as evenly as possible over the whole surface area. A view of a bonding fixture for lap joints is presented in Fig. 3.20.

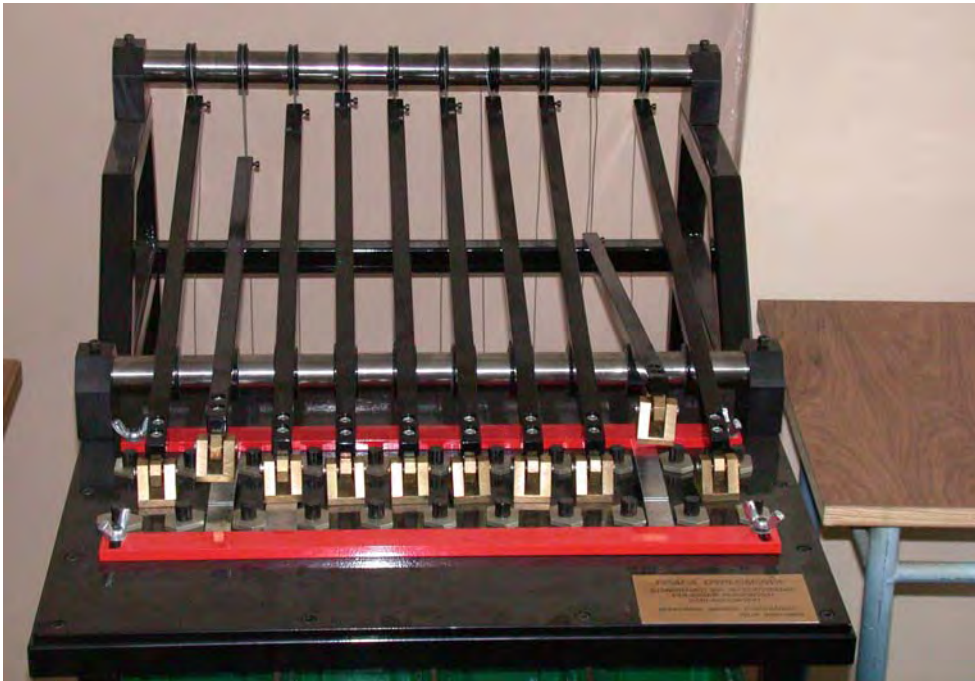

Fig. 3.20. View of a bonding fixture for lap joints

More information on the major types of equipment for applying pressure to elements joined through adhesive bonding is provided in Chapter 6.

3.1.7. Finishing and bond inspection

Preliminary inspection of established adhesive bonds usually consists in visually inspecting the bond and may be followed by the finishing treatment of the bond. Finishing treatment typically consists in the removal of adhesive flash at both sides of the lap joint, or in chamfering the elements bonded if such an operation could not have been made before. Part of the adhesive flash, located directly in the corner of the joint should be left in place (if the structure permits it). This is illustrated schematically in Fig. 3.21a.

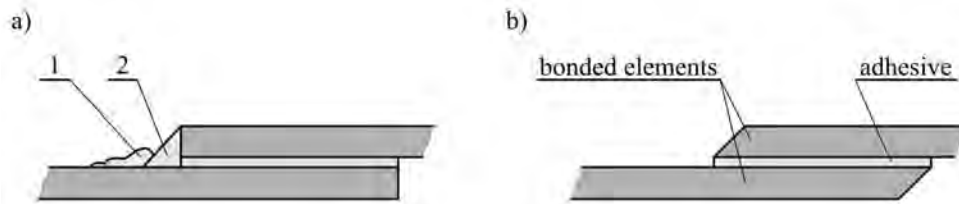

Fig. 3.21. Formation of lap joints: a) flash of adhesive in a lap joint: 1 – part of the adhesive flash to be removed, 2 – corner of the joint filled with adhesive, b) joint with chamfered ends of the lap

Leaving the corner of the joint filled with adhesive significantly reduces the concentration of stresses. The effect is similar, though somewhat lesser, to that achieved through the application of chamfering of lap joints (Fig. 3.21b).

Other types of bond inspection are related to the testing the continuity of bonding in the adhesive and cohesive zones. Such testing is most frequently made with the help of X-ray or magnetic flaw detection. Also destructive tests are performed, concerning the static and dynamic strength of bonds, most often on so-called “companion samples”.

Additionally, bond areas are protected with paint coating. This significantly reduces water diffusion into the adhesive zone and thus the decrease in the strength of the bond in the function of time.

3.2. Principles of selection of technological conditions of bonding

The most important technological conditions of adhesive bonding are:

- curing temperature,
- curing time,
- clamping pressure per unit of bonded surface.

It is advantageous to conduct the process of adhesive bonding at ambient temperature. This does not require the use of complex heating equipment that would have to ensure uniform heating of the whole bonding zone. It turns out, however, that bonds cured at higher temperature (this concerns many adhesives, especially epoxy adhesives) are characterized by better thermal and chemical resistance. Hence adhesive joints used in important structures are frequently cured in two stages – after curing at ambient temperature a process of after-bake is applied. The purpose of after-bake is to increase of degree of crosslinking. It should be noted, however, that it frequently involves an increase in the rigidity of the cured adhesive. Too high temperature of after-bake may also be the cause of initiation of the process of destruction of the adhesive, especially when bonding certain materials containing elements conducive to the degradation of adhesives (e.g. iron).

In the case of curing adhesives at higher temperatures, the time of curing is also important and manufacturers' recommendations in this respect should be observed. At present, leading manufacturers of adhesives have experimental data that have been accumulated over years, so their recommendations are more and more credible. The process of after-baking can last from several minutes to about two hours.

Unit clamping pressure is also an important parameter and its value depends on the following major factors:

- value of curing shrinkage (chemical and thermal),
- form of adhesive (liquid adhesive, film),
- viscosity of adhesive,
- topographic features of the elements bonded.

High rate of shrink during curing (e.g. of phenolic adhesives) requires a higher value of clamping pressure. Most adhesives of new generation are characterized by low curing shrink rates. Low rates of chemical shrinkage are also characteristic of the still-popular epoxy adhesives.

Adhesives in the form of film require considerable clamping pressures during bonding. This is understandable, as the pressure allows for good wetting of surface when heating the bond area. Adhesive film should be pressed to the bonded surfaces during their mutual alignment. It is deformed in an elastic-plastic manner on the micro-irregularities of the bonded surfaces. Frequently, however, at that stage of adhesive bonding air bubbles are sealed at the bottom of such surface micro-irregularities. When the bonded area is heated, clamping pressure is necessary to facilitate filling of the surface micro-irregularities with adhesive. In such cases it is recommended to conduct the curing under negative pressure (in an autoclave), in order to achieve de-aeration of the bond zone.

Viscosity of adhesive is close related with its wetting ability. Higher viscosity means the necessity of applying increased clamping pressure.

The topographic features of the bonded surfaces characterize the surfaces as to their wetting ability. Surfaces with high level of smoothness are easily coated with adhesives if they are characterized by high values of free surface energy. Surfaces that are strongly „developed” require the application of clamping pressure during the bonding to facilitate filling surface micro-irregularities with adhesive.

References

- 3.1. Burakowski T., Wierzchoń T.: Inżynieria powierzchni metali. WNT, Warszawa, 1995.
- 3.2. Cagle Ch. V.: Kleje i klejenie. WNT, Warszawa, 1987.
- 3.3. Comyn J.: Contact angles and adhesive bonding. Int. J. Adhesion and Adhesives. Vol. 12, N. 3 July 1992.
- 3.4. Gołębiowski J.: Ocena metod badania wytrzymałości złączy adhezyjnych zawierających folię polimerową. Polimery 10/1998.

- 3.5. Good J.R. i in. Fundamentals of Adhesion (red. Lee L. H.), Dekker, Nowy Jork, 1991.
- 3.6. Hebda M., Wahal A.: Trybologia. WNT, Warszawa, 1980.
- 3.7. Jańczuk B., Białopiotrowicz T.: Swobodna energia powierzchniowa niektórych polimerów. Polimery 7/1987.
- 3.8. Jańczuk B.: Adhezja wody do powierzchni polimerów. Polimery 1/1989.
- 3.9. Kaczmarek J.: Podstawy obróbki wiórowej, ścierniej i erozyjnej. WNT, Warszawa, 1970.
- 3.10. Kuczmaszewski J.: Podstawy konstrukcyjne i technologiczne oceny wytrzymałości adhezyjnych połączeń metali. Wydawnictwa Politechniki Lubelskiej, 1995.
- 3.11. Kuczmaszewski J.: Konstytuowanie właściwości adhezyjnych warstwy wierzchniej. Folia Societatis Scientiarum Lublinensis. Vol 5, nr 2/1996.
- 3.12. Kuczmaszewski J. i in.: Konstytuowanie dla potrzeb klejenia i uszczelniania właściwości adhezyjnych wybranych materiałów konstrukcyjnych. Raport końcowy z realizacji projektu badawczego 7. T08E.075.14. Politechnika Lubelska, 1999.
- 3.13. Oczóś K., Porzycki J.: Szlifowanie. Podstawy i technika. WNT, Warszawa, 1986.
- 3.14. Przybylski W.: Technologia obróbki nagniataniem. WNT, Warszawa, 1987.
- 3.15. Rudawska A.: Wpływ czynników technologicznych i konstrukcyjnych na wytrzymałość połączeń adhezyjnych blach ocynkowanych. Politechnika Lubelska, Wydział Mechaniczny, 2003.
- 3.16. Rudawska A., Kuczmaszewski J.: Klejenie blach ocynkowanych. Politechnika Lubelska. Wydawnictwa Uczniowskie, 2005.
- 3.17. Sękowska A., Sękowski S.: Kleje w naszym domu. WNT, Warszawa, 1991.
- 3.18. Sikora R.: Przetwórstwo tworzyw wielkocząsteczkowych. Wydawnictwo Edukacyjne Zofii Dobkowskiej, Warszawa, 1993.
- 3.19. Żenkiewicz M., Gołębiowski J., Lutomirski S.: Doświadczalna weryfikacja niektórych elementów metody van Ossa-Gooda, Polimery 3/1999.
- 3.20. Żenkiewicz M.: Zmiany warstwy wierzchniej folii polietylenowej pod wpływem wyładowań niezupełnych. Polimery 1/1989.

Chapter 4

Producibility of bonded structures

4.1. Factors determining producibility in bonding operations

The producibility of a structure [4.2, 4.5, 4.9] is a set of features determining the „compatibility” of the structure with the technological process that is to be applied, at the same time ensuring the possibility of applying a process that will provide the lowest possible cost of producing the structure. Features of structures that are important from the viewpoint of adhesive bonding are presented schematically in Fig. 4.1.

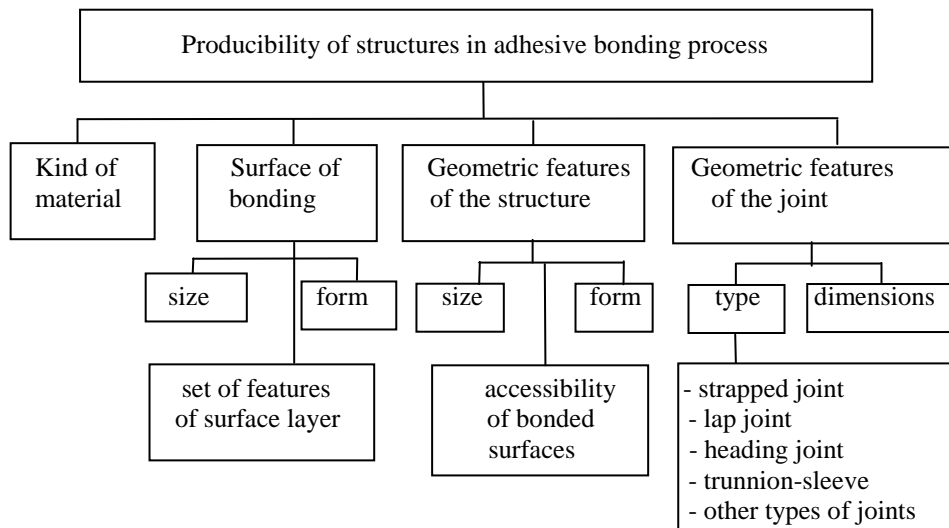

Fig. 4.1. Primary features determining the producibility of structures in the operations of adhesive bonding

As follows from Fig. 4.1, the producibility of structures is determined by numerous factors related both to the geometric and the physical features of the elements joined.

The kind of material is a fundamental factor determining the producibility of a structure in the process of adhesive bonding. The condition of effective bonding is, first of all, good wetting of the bonded material by the adhesive. Hence the simple conclusion, discussed in greater detail in Chapter 1, that the value of free surface energy of the metal bonded must be higher than the value of free surface energy of the adhesive used. Preferably, the difference between the values of free surface

energy should exceed 10 mJ/m^2 . Correct relation between the free surface energy values of the bonded material and the adhesive is not, however, a sufficient condition for effecting a good bond. Also very important are the structure and strength properties of the layer of oxides, sulphides, and other chemical compounds forming the chemical and physical adsorption layers which, in the case of metals, e.g. aluminium alloys, form rapidly after the completion of preparatory operations for adhesive bonding. Certain oxides are very weakly bound with the substrate (e.g. with the surface of structural carbon steels); in this case they should be carefully removed from the bonded surface before the actual bonding, even though the value of free surface energy of a „corroded” surface is high. In other cases (e.g. aluminium alloys) oxides are very strongly bound with the substrate, hence, in relevant structures (e.g. in aerospace), the process of producing such oxides is conducted on purpose (e.g. anode oxidation). Moreover, such a layer of oxides has a high value of free surface energy.

If we assume that, from the viewpoint of the material, the fundamental criterion of producibility of a structure in the process of adhesive bonding is the cost of surface layer preparation, then we can accept that more favourable are those materials for which surface layer preparation for bonding is limited to simple machining and degreasing. The purpose of the machining is to remove the physical adsorption layer and the layer of oxides, while degreasing is performed to remove contaminants deposited in the course of machining and remaining particles of fats and greases. With such an assumption we can state that carbon steels and cast-irons are materials that improve producibility in operations of adhesive bonding, while alloy steels, aluminium alloys, and copper, titanium and magnesium alloys require special and costly methods of surface layer preparation, thus deteriorating the producibility of structures. The subject of methods of surface layer preparation for those materials is discussed in greater detail in section 3.1.

An important factor affecting the producibility of bonded structures is the size and form of the bonded surface. The most producible are flat surfaces of small dimensions. It is then possible to use simple devices for the application of adhesives [4.4], and adhesive application by hand is also easy. Considerable problems are involved where concave or convex surfaces are concerned – these usually require the application of adhesive film or adhesives with increased viscosity. Increased viscosity entails poorer wetting, so the operation of bonding requires the application of effective clamping pressure over the whole bonding surface area, which of course increases the costs. Bonding surfaces of considerable area require uniform application of the layer of adhesive. The process of adhesive application should take a relatively short period of time, which is especially important in the case of chemo-setting adhesives. Modern chemo-setting adhesives have a relatively short setting time, hence excessive „stretching in time” of adhesive application may cause a differentiation in the properties of the bond in its various zones, with a resultant decrease in the strength of the bond effected. Also important is the set of features,

especially stereometric, of the bonded surfaces, as they have a strong effect on the wetting of the surfaces.

Another important group of factors is related to the geometric features of the structure as a whole, if adhesive bonding is employed at the stage of its assembly. This relates primarily to the accessibility of the bonded surfaces, and to their spatial orientation. Difficult to bond are such elements whose bonded surfaces are oriented in the vertical plane, and even more difficult those for which the adhesive is applied on the “ceiling” surface. Such an orientation of surfaces, especially when the surfaces are of considerable dimensions, makes a structure to be highly non-producible in adhesive bonding operations [4.3, 4.7, 4.8].

The geometric features of a joint, and especially the type of the joint, have a strong effect on the producibility of a structure in adhesive bonding operations. Figures 4.2 – 4.15 present the more important types of adhesive joints with a synthetic evaluation of their producibility [4.1, 4.4, 4.6].

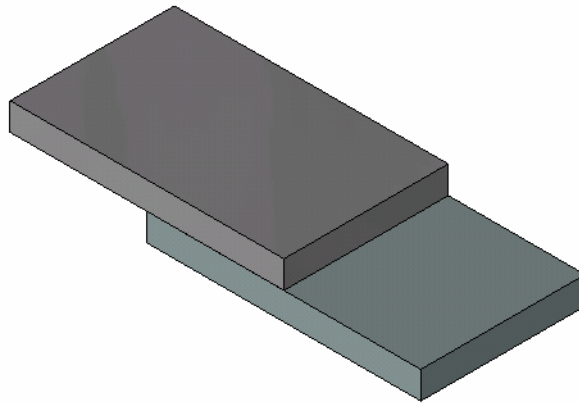

Fig. 4.2. Lap joint - a producible type of joint, most frequently used; eccentricity of load causes deterioration of the strength properties

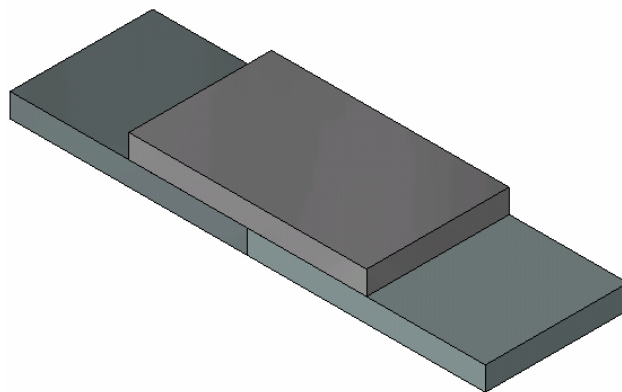

Fig. 4.3. Strapped joint – easy to make, requires the application of a strap

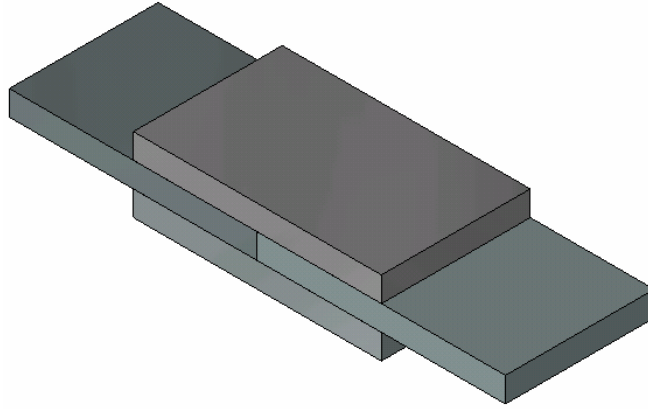

Fig. 4.4. Double-strapped joint – more difficult to make than a simple strapped joint; increases the weight of the structure, requires the fabrication of straps, eliminates the eccentricity of loads, has good strength characteristics

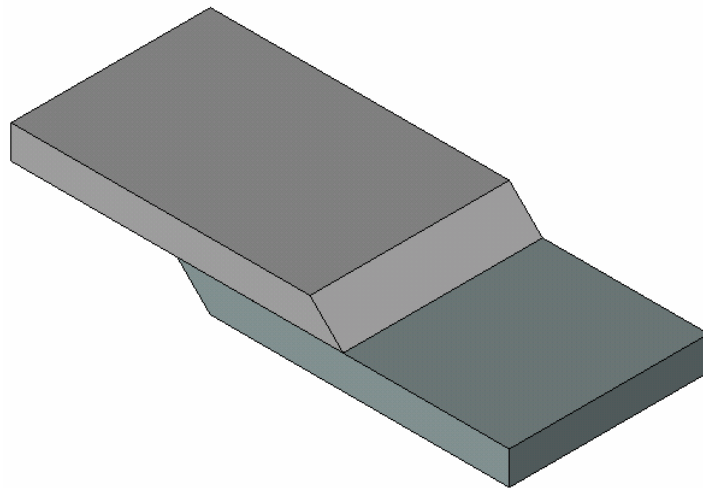

Fig. 4.5. Lap joint with chamfered overlap edges; higher strength than that of simple lap joint due to lower concentration of stresses at ends of overlap; requires troublesome chamfering of edges

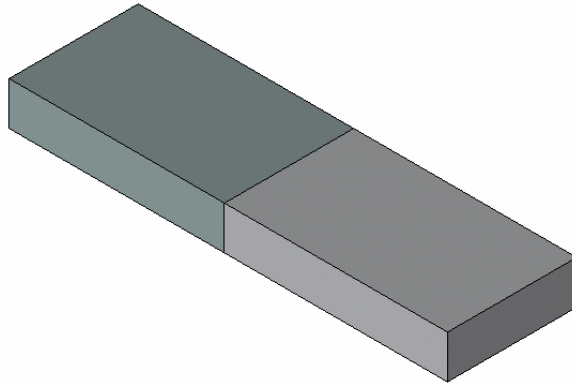

Fig. 4.6. Simple heading joint – easy to make, however cohesive peel strength of cured adhesive is limited

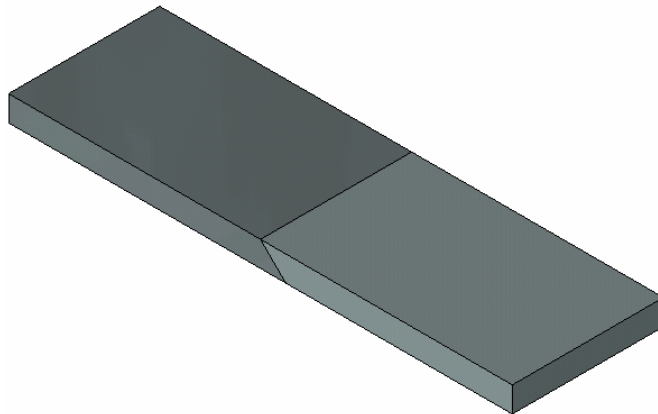

Fig. 4.7. Chamfered heading joint – higher strength than that of simple heading joint, requires the additional operation of chamfering

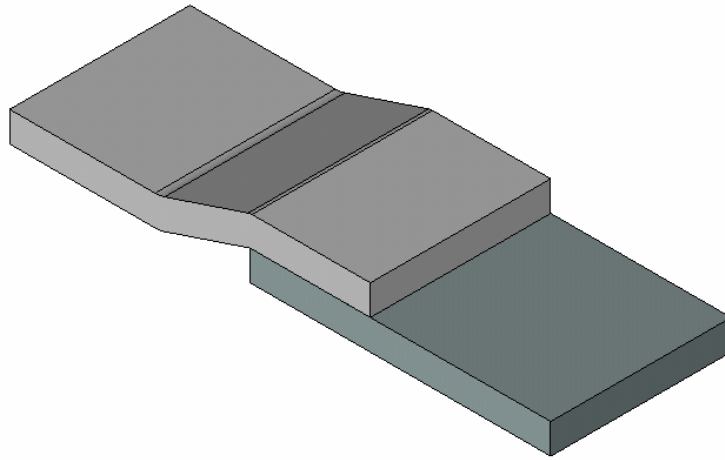

Fig. 4.8. Lap joint with offset overlap section; eliminates eccentricity of loads, easy to make, but requires the additional operation of bending the overlap section

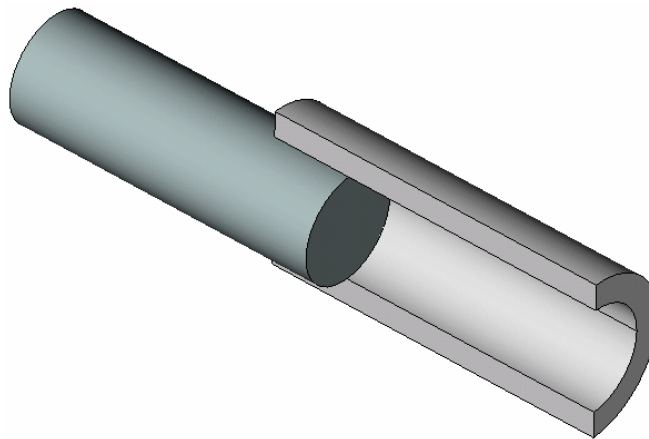

Fig. 4.9. Trunnion-sleeve joint – high strength, but difficulty in achieving concentricity of bonded elements

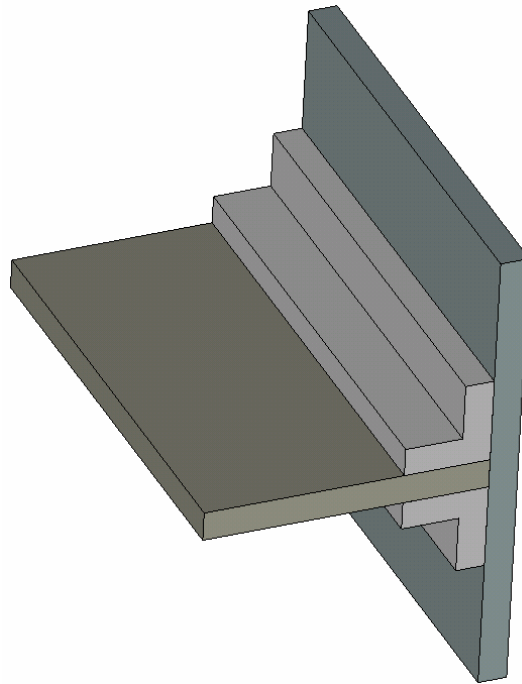

Fig. 4.10. Compound joint – an example of adhesive joint with enhanced rigidity with simultaneous improvement in strength

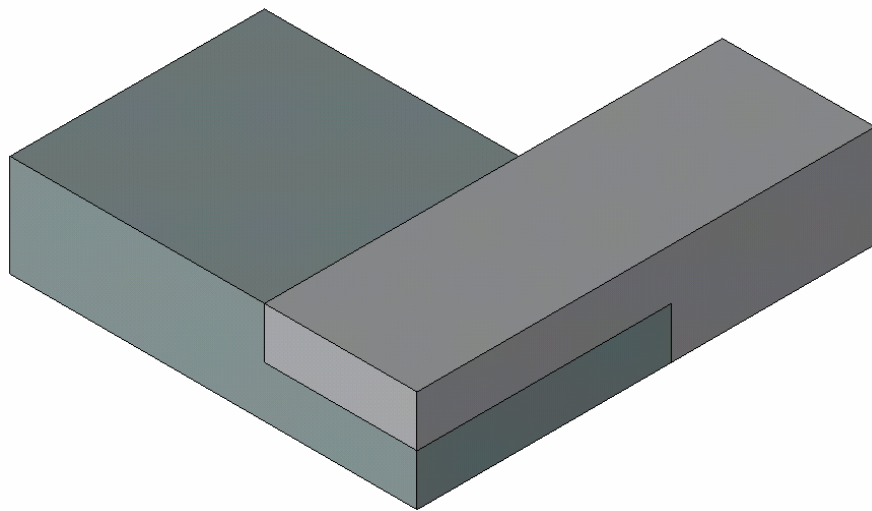

Fig. 4.11. High-strength angle joint capable of transmitting loads in various directions; requires the operation of machining the overlap sections

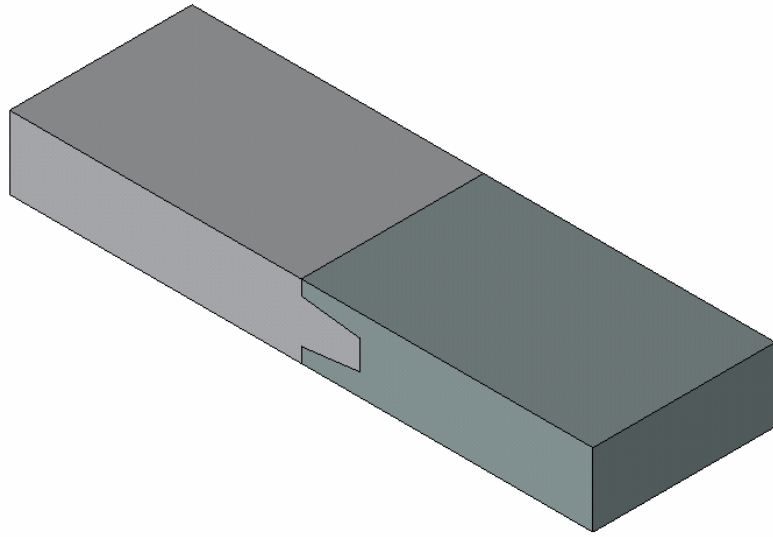

Fig. 4.12. Feather joint - example of improving the strength of an adhesive heading joint

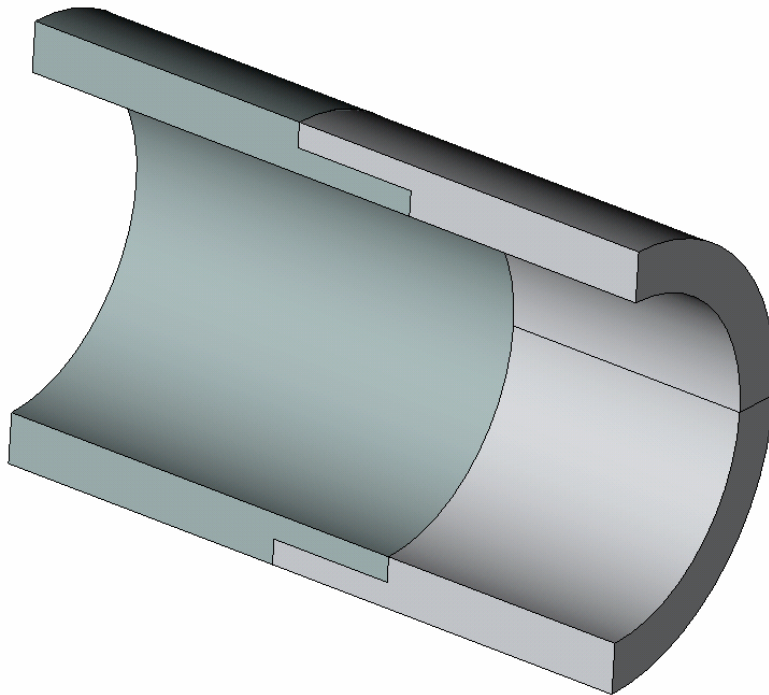

Fig. 4.13. Lap-heading joint - example of adhesive bonding of tubes; this type of joint improves the strength of the connection, but requires appropriate formation of the overlap sections

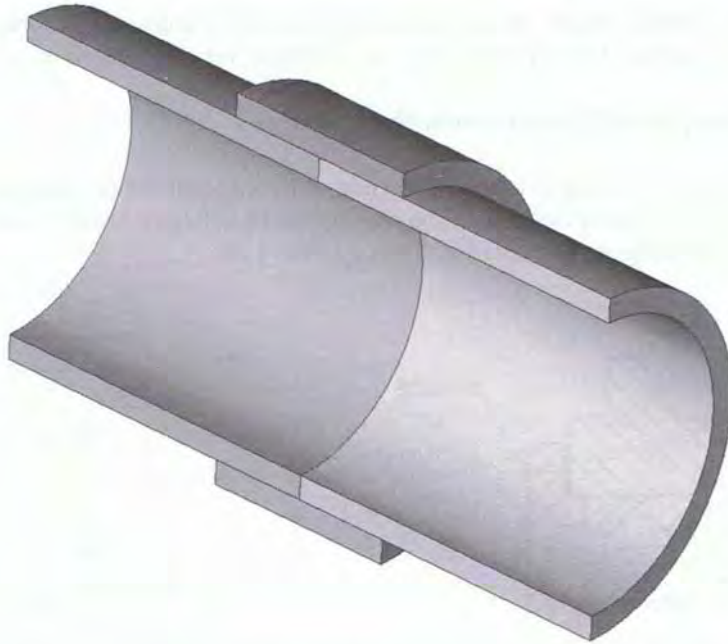

Fig. 4.14. Strap-sleeve joint - example of adhesive bonding of tubes with a clamping sleeve; used in conditions of high pressure

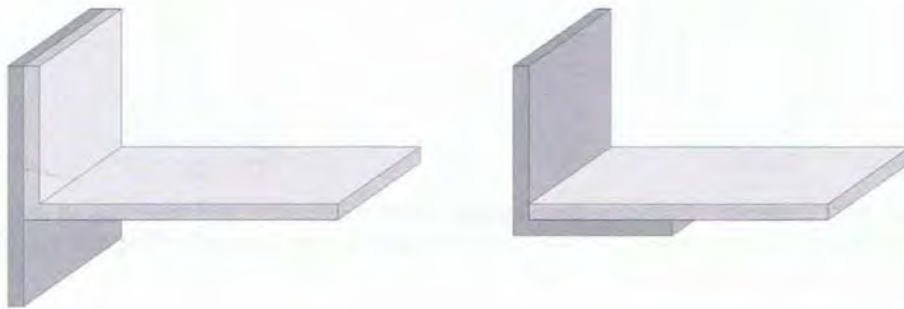

Fig. 4.15. Angle joints; easy to make, shear stress should dominate in the loads transmitted

The presented examples of types of adhesive joints and the brief description of factors characterizing the producibility of bonded structures, do not exhaust the problem under consideration. Also important are such values as the thickness of the elements bonded, thickness of the layer of adhesive, bending stiffness and tensile

strength. These values, in combination with those analysed before, provide a composite image of the problem of producibility of bonded structures.

4.2. Examples of typical assembly operations

Adhesive bonding is a typical method of joining applied in numerous branches of industry. Several examples of the application of adhesive bonding and sealing in machine building are presented in figures 4.16 – 4.23.

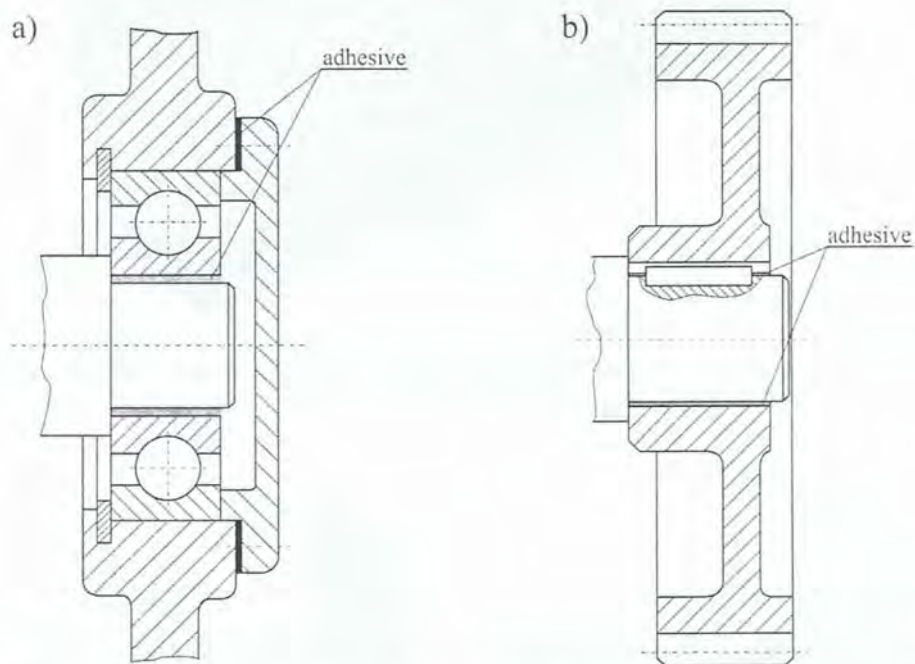

Fig. 4.16. Examples of adhesive bonding application in assembly: gear mounting on shaft trunnion using a key or through adhesive bonding (a), adhesive fixing of rolling bearings (b)

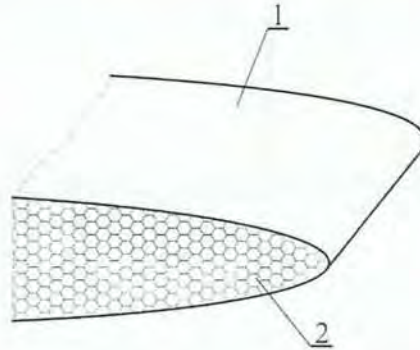

Fig. 4.17. Example of filling of structures with „honeycomb filler”; 1 – sheetmetal skin, 2 – “honeycomb” filler

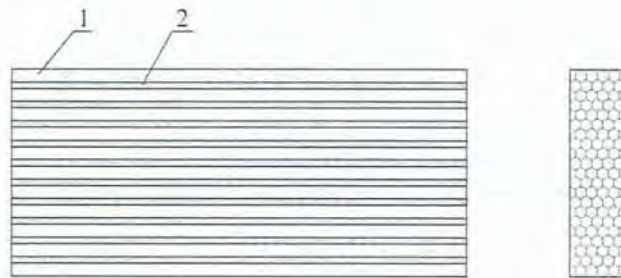

Fig. 4.18. Bonding of foil in the production of „honeycomb filler”; 1 – applied adhesive strip, 2 – aluminium foil or other material

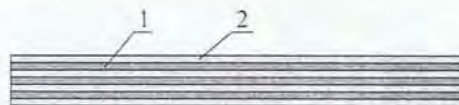

Fig. 4.19. Bonding of layers of material in the production of laminated composites; 1 – adhesive, 2 – bonded materials (fabrics, mats, boards, sheets)

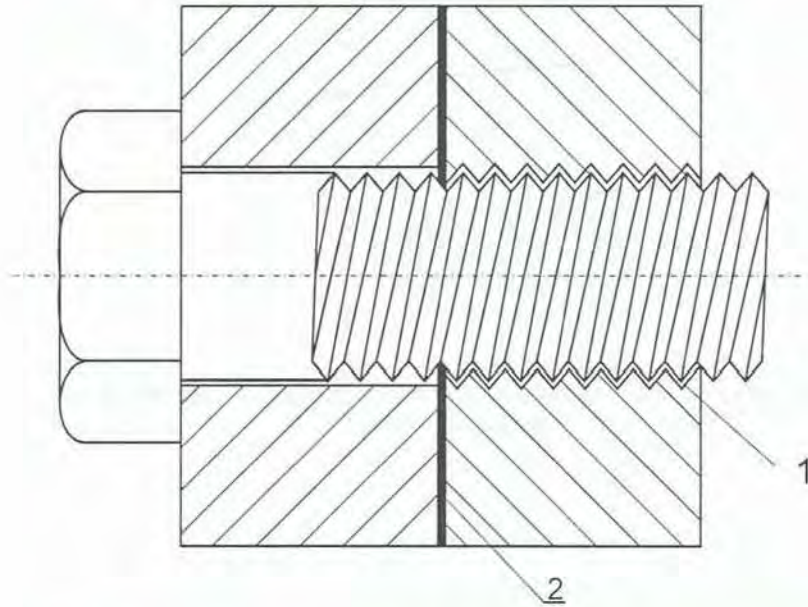

Fig. 4.20. Example of the application of adhesives in sealing threaded joints; 1 – sealing of the nut-bolt area, 2 – sealing between joined elements

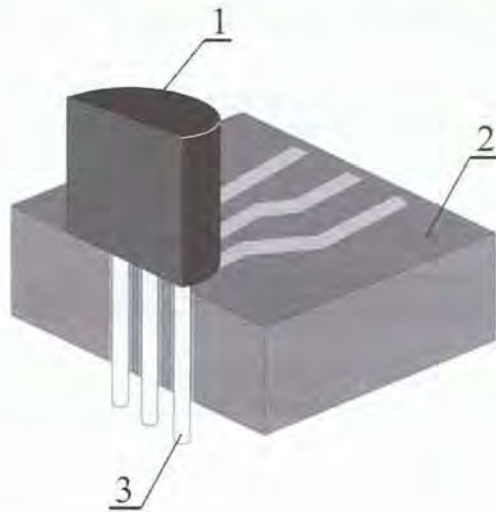

Fig. 4.21. Mounting of electronic components; 1 – assembly board, 2 – connected element, 3 – wire terminals (bonded)

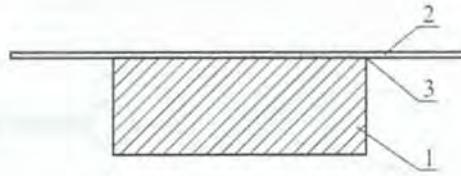

Fig. 4.22. Lining of elements of structures (adhesive bonding of foils) for decorative, soundproofing or protective purposes; 1 – element of structure, 2 – decorative-protective foil, 3 – layer of adhesive

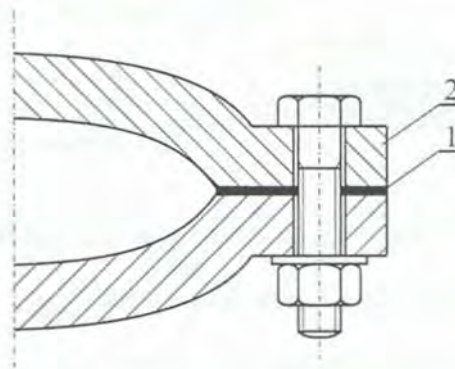

Fig. 4.23. Sealing of flange-type joints; 1 – seal, 2 – element of structure

The examples presented in figures 4.16 – 4.23 are the most frequently used in assembly operations. However, there are many other areas where adhesives are used in assembly operations, for the production of packaging elements, in special engineering processes, etc. Another interesting application is the use of renovation materials for repair work. An example of the technology of repair of a cracked tank is presented in Fig. 4.24 below:

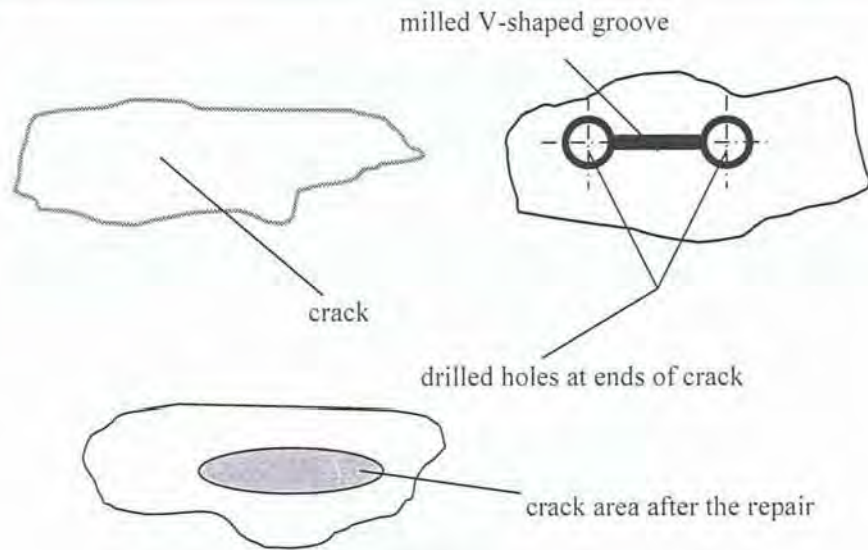

Fig. 4.24. Example of cracked tank repair using renovation putty

The technology of repair of such a crack is as follows:

1. Clean the crack area and estimate the size of the crack
2. Drill holes at crack ends (diameter of the holes depends on the character of the crack, in Fig. 4.24. the diameters are somewhat oversize for clarity of presentation)
3. Make a milled V-shaped groove between the holes
4. Clean and degrease the area of repair
5. Fill the drilled holes and milled groove with repair putty
6. Cure the putty
7. Finish the repair area (apply grinding to the area of repair)
8. Degrease the area
9. Apply a protective coating.

It is worth noting that when modifying renovation/repair materials one should take special care to try to achieve properties as similar to those of the material repaired as possible.

4.3. Conclusions

The technology of adhesive bonding permits the obtaining of low unit costs of joints as compared to other technologies (e.g. threaded joining).

Adhesive bonding is a highly versatile technology in terms of production volume. Bonding operations can be used in unit production, using the simplest tools and equipment, as well as in batch and mass production, due to the ease of their automation.

Among the advantages of the technology of adhesive bonding we can include the possibility of producing light, strong and rigid structures, of joining elements with complex shapes and very small dimensions, of various materials and with varied thickness, effective sealing against the migration of liquids, gases, etc.

Among the limitations in the application of adhesive bonding we can include limited mechanical and thermal strength and service life, low resistance to the effect of variable atmospheric and environmental influences, the lack of an adhesive possessing the features of an all-purpose bonding agent (necessity of selecting suitable adhesives for particular applications), non-linear relation between the strength of bonds and the area of bonded surfaces, need for rigorous observance of bonding technology to obtain bonds with satisfactory strength, as well as limitations resulting from the specific requirements of various branches of technology. The subject matter of producibility of design in bonding processes is only rarely addressed in the literature, although it is extremely important, especially in the economic aspect.

At present we can observe an ongoing development in the technology of adhesive bonding related to notable advances in the chemistry of adhesives and sealants. This results from the capabilities and advantages of the technology of adhesive bonding and from the fact that in many cases it is the only effective and practicable method of joining structural elements.

References

- 4.1. Czaplicki J. i inni: Klejenie tworzyw konstrukcyjnych. Wydawnictwa Komunikacji i Łączności, Warszawa 1987 r.
- 4.2. Feld M.: Technologia budowy maszyn. PWN, Warszawa, 1995.
- 4.3. Kuczmaszewski J.: Podstawy konstrukcyjne i technologiczne oceny wytrzymałości połączeń metali. Wydawnictwa Uczelniane PL, Lublin 1995 r.
- 4.4. Kuczmaszewski J.: Technologia śmigłowców. Teoria i technika klejenia. Wydawnictwa Uczelniane PL, Lublin 1990r.
- 4.5. Łunarski J.: Połączenia klejowe w procesach montażu. Technol. i automatyzacja montażu. 2/1994.
- 4.6. Łunarski J., Szabajkiewicz W.: Automatyzacja procesów technologicznych montażu maszyn. WNT, Warszawa, 1993.
- 4.7. Porębska M., Skorupa A.: Połączenia spójnościowe. PWN, Warszawa, 1993.
- 4.8. Wieczorowski K., Żurek J.: Uwarunkowania automatyzacji montażu. Przegląd Mechaniczny 23/1988.
- 4.9. Żurek J., Bartczak S.: Ocena technologiczności konstrukcji wyrobu pod kątem automatyzacji i robotyzacji jego montażu. Zeszyty Naukowe Politechniki Rzeszowskiej, nr 45/1988.

Chapter 5

Strength of bonded joints

5.1. Stress analysis in bonded joints

Adhesive bond is a specific type of a sandwich structure. Cured adhesive is usually a material strongly differing in its physical properties from the material or materials bonded. The state of stress in a bond is primarily a function of the state of loading. In bonded structures the dominant type is lap joints with shear loading. Fig. 5.1 presents schematically a simplified model of stress distribution along the length of overlap.

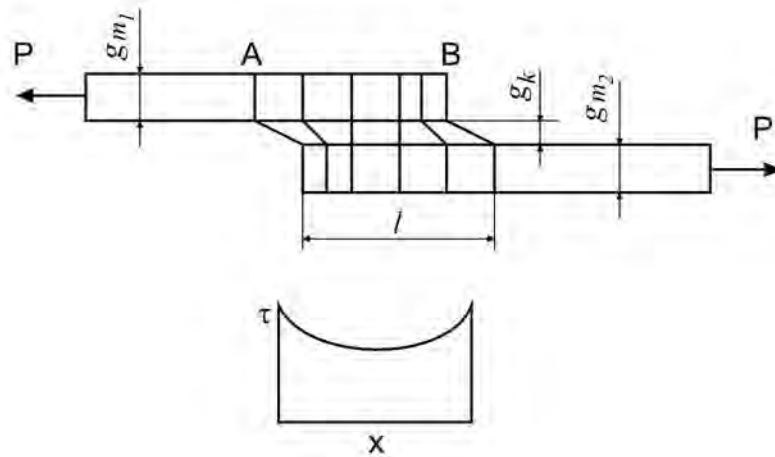

Fig. 5.1. Simplified model of stress distribution on the length of overlap

The first analysis of shear stress distribution in lap joints was made by Volkersen [5.1, 5.5, 5.9], according to whom shear stresses on the length of the overlap can be described by the equation

$$\tau_x = A_1 \cosh \omega x + A_2 \sinh \omega x \quad (5.1)$$

where: A_1, A_2 – constants defined by boundary conditions, $\omega^2 = (1+\psi)\phi$, $\psi = g_{m1}/g_{m2}$, g_{m1}, g_{m2} – thickness of bonded elements when $g_{m1} = g_{m2}$, $\omega = \sqrt{2\phi}$,

$\phi = \frac{Gl^2}{Eg_m g_k}$, where g_k is the thickness of the layer of adhesive. Assuming that

$\bar{\tau} = \frac{\tau_x}{\tau_m}$, and $X = x/l$, the equation of stress distribution can be reduced to the non-dimensional form

$$\bar{\tau} = \frac{\omega \cosh \omega X}{2 \sinh \omega / 2} + \left(\frac{\psi - 1}{\psi + 1} \right) \frac{\omega \sinh \omega X}{2 \cosh \omega / 2} \quad (5.2)$$

where: τ_x – value of tangential stress in the analysed section, τ_m – mean tangential stress.

The highest tangential stresses occur at the ends of the overlap and equal

$$\bar{\tau}_{\max} = \sqrt{\frac{\phi}{2}} \coth \sqrt{\frac{\phi}{2}} \quad (5.3)$$

When the value of tangential stress exceeds the value of destructive stress τ_n the bond breaks. Knowing the value of the stresses and the dimensions of the joint, i.e. the length of overlap l and the width of overlap b , and assuming the same tensile stiffness for both bonded elements, i.e. $E_1 g_{m1} = E_2 g_{m2}$, we can formulate the relation for the value of force breaking the bond

$$P = \tau_n b \sqrt{\frac{2g_k g_m E}{G_k}} \frac{\sinh ml}{\cosh ml + 1} \quad (5.4)$$

$$\text{where: } m = \sqrt{\frac{G_k g_{m1} E_1 + g_{m2} E_2}{g_k g_{m1} E_1 g_{m2} E_2}} \quad (5.5)$$

We must be aware of the fact, however, that in a lap joint there are also normal stresses which, under certain circumstances, may decide of the breaking of the bond.

The presented analytical consideration and obtained solution results from the adoption of boundary conditions necessary for the calculation of constants of integration. The consequence of such a solution is the occurrence of the greatest tangential stresses at the edge of the overlap. In reality, the tangential stress must be zero at the edge. This edge effect can be well illustrated by means of finite elements analysis. Fig. 5.2. presents examples of such analysis.

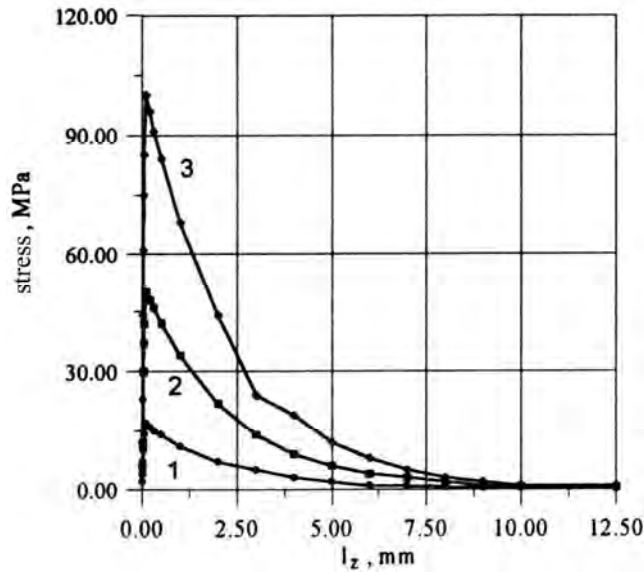

Fig. 5.2. Tangential stress distribution along the length of overlap as determined with the finite elements method for the following conditions: $E = 2,1 \times 10^5$ MPa, $g_k = 0,15$ mm, $g_m = 2$ mm, 1 – $F = 900$ N, 2 – $F = 2700$ N, 3 – $F = 5400$ N, $l_z = 25$ mm [5.22]

Analysing tangential stress distribution on the length of the overlap we encounter the problem of determining the limit length of overlap, i.e. the length above which change in the value of maximum tangential stress is negligible, which means also that further increase in the length of overlap is pointless as it does not lead to further increase in the load capacity of the bond. Knowledge of the limit length of overlap has also an important application significance as it permits indirect calculation of the limit thickness of bonded elements, i.e. the thickness resulting from equality:

$$k_r \cdot g_m \cdot b = \tau_k \cdot l_z \cdot b \quad (5.6)$$

hence:

$$g_m = \frac{\tau_k l_z}{k_r} \quad (5.7)$$

where: k_r – permissible tensile stress of bonded materials, b – width of overlap, τ_k – permissible shear stress of cured adhesive, l_z – length of overlap. Skipping detailed analysis, the limit length of overlap can be calculated from the relation [5.5, 5.9, 5.23]:

$$l_{gr} > 5 \sqrt{\frac{g_k g_m E_m}{2G_k}} \quad (5.8)$$

If we assume that the thickness of the layer of adhesive is approximately constant, and bonding concerns one material with a set thickness, we can see that the limit length of overlap is, in such a case, a function of stiffness of the adhesive. Hence, the strength of an adhesive joint can be predicted on the basis of the physical properties of the adhesive when cured, among other things. The limit length of overlap for steels and aluminium alloys, determined analytically, is presented in Fig. 5.3 and 5.4.

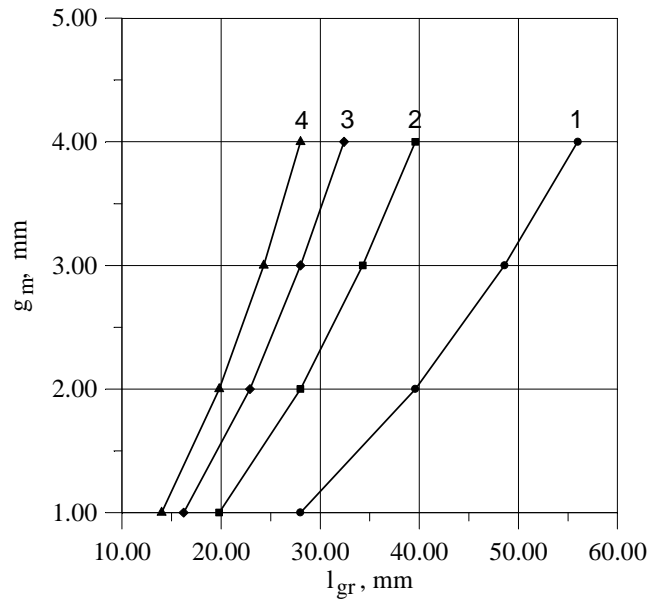

Fig. 5.3. Analytical relation $l_{gr} = f(g_m)$ for steel at: 1 – $G_k = 500$ MPa, 2 – $G_k = 1000$ MPa, 3 – $G_k = 1500$ MPa, 4 – $G_k = 2000$ MPa, [5.22]

Volkersen's theory does not consider the eccentricity of load force effect, i.e. also of the bending moment and, consequently, normal stresses, while sometimes it is normal stresses that decide about the de-cohesion of lap joints subjected to shear loads.

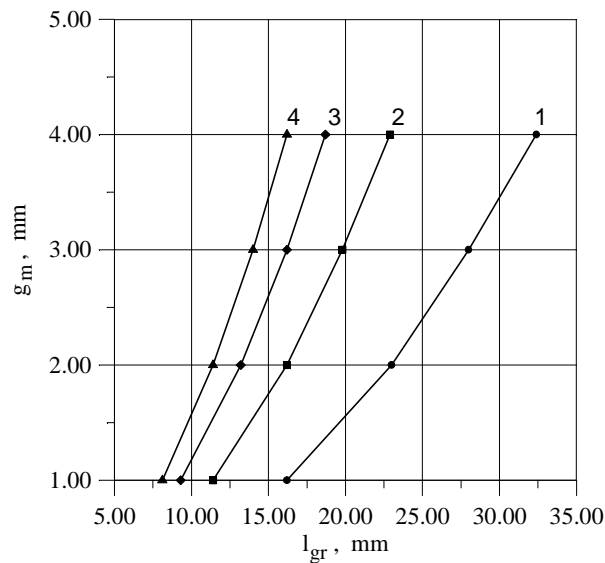

Fig. 5.4. Analytical relation $l_{gr} = f(g_m)$ for aluminium alloys at: 1 – $G_k = 500$ MPa, 2 – $G_k = 1000$ MPa, 3 – $G_k = 1500$ MPa, 4 – $G_k = 2000$ MPa, [5.22]

Physical interpretation of the limit length of overlap is well illustrated by analysis with the method of finite elements. Fig. 5.5 presents tangential stress distribution along the length of overlap for overlaps shorter than the limit length, approximately equal to the limit length, and longer than the limit length. As can be seen, in the centre part of overlap, for $l > l_{gr}$ joint, the adhesive transmits virtually no load; such a joint, for the given load conditions and geometric features of the joint, is clearly over-dimensioned.

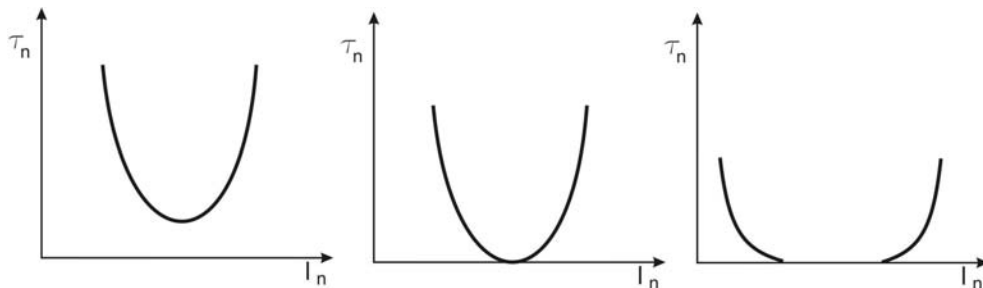

Fig. 5.5. Stress distribution $\tau_n = f(l_n)$ along overlap length: a – shorter than the limit, b – approx. equal to the limit, c – longer than the limit

Goland and Reissner [10] made an analysis of stress distribution in adhesive lap joints, taking into consideration the occurrence of bending moment. Leaving out the thickness of the layer of adhesive, bending moment in a lap joint can be presented as follows:

$$M_o = k_o P \frac{g_m}{2} \quad (5.9)$$

where P is the load force, t is the thickness of the bonded elements (with the assumption that the elements bonded are of the same thickness), and k_o is a coefficient dependent on the value of the load applied. The thickness of the adhesive layer is not included in this case. For low loads the characteristic turn-in of the ends of the overlap towards the centre plane of the bonded materials is not observed, and in such a situation $k = 1$. Considering the Goland and Reissner analysis, the highest normal stresses at the ends of the overlap are:

$$\sigma_{\max} = \frac{\sigma_0 k_o}{2} \sqrt{\frac{6E_k g_m}{Et_k}} \quad (5.10)$$

where: $\sigma_0 = P/bg_m$, b – width of the overlap.

In this context, it becomes interesting to formulate the criterion of the bond effort. The problem is not an easy one. The adoption of effort hypotheses based on rheological models, typical for structural elements of polymer materials, does not always ensure correct modelling of the physical properties of the adhesive, due to the specific dimensions and working conditions of the bond.

Our own studies in the range of destructive testing, as well as finite elements analysis, permit also the adoption of the hypothesis of the highest normal stress. The reduced stress for that hypothesis has the form:

$$\sigma_{red} = \frac{\sigma_r}{2} + \frac{1}{2} (\sigma_r^2 + 4\tau^2)^{0,5} \quad (5.11)$$

Mutual relations between the values of tangential stress, normal stress and reduced stress depend to the greatest extent on the thickness of the layer of adhesive and on the thickness of the bonded materials. The analysis performed assumes that an adhesive bond responds to a load as an elastic body. For adhesives with high elasticity we can use in the analysis the secant modulus of elasticity E_s – the idea of that correction is presented in Fig. 5.6.

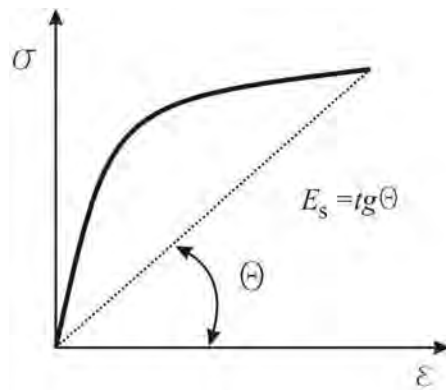

Fig. 5.6. Determination of the secant modulus of elasticity [5.9]

Advances in chemical technology, in the field of structural adhesives, cause that more and more often adhesive bonding is applied for mounting and securing of gears and pulleys, bearings, and other axis-symmetrical elements of structures. Such bonds are characterized by high strength; the adhesive is only shear-loaded, which is the type of load that is best transmitted by adhesive bonds.

For the determination of tangential stresses one can employ the Grant model [5.1], the idea of the method being presented in Fig. 5.7.

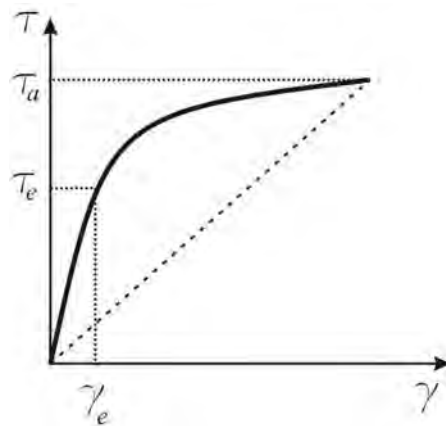

Fig. 5.7. Theoretical curve of deformation of a layer of adhesive

When $\gamma < \gamma_e$ then $\tau = \gamma G_e$, and if $\gamma > \gamma_e$ the stress is calculated as follows:

$$\tau_a = \tau_e + \left(\frac{\alpha\beta}{\alpha + \beta} \right) \quad (5.12)$$

where $\alpha = \gamma G_c - \tau_e$, $\beta = \tau_{\max} - \tau_e$

Modern structural adhesives clearly display viscoelastic properties, hence the inclusion - in strength analysis – of the course of adhesive deformation as in Fig. 5.7 is justified.

5.1.1. Effect of edge line length

It was expected that the existence of adhesive flash on the edges of the bond and the concentration of stresses may, in the case of bonds with small bonding area, significantly affect the strength of the bond. Therefore, a series of experiments was performed [5.21] with the use of adhesives type K-153 and WK-3, i.e. adhesives which – when cured – produce bonds with very low stiffness. Samples had a bonding surface of $S = 6 \text{ cm}^2$ and the following lengths of the bond edge line: $l_s = 113 \text{ mm}, 130 \text{ mm}, 165 \text{ mm}, 177 \text{ mm}, 195 \text{ mm}, 205 \text{ mm}$. Change in the length of the bond edge line was achieved by varying the shapes of the bonding area while retaining the length of overlap. An example of such a modification is presented in Fig. 5.8.

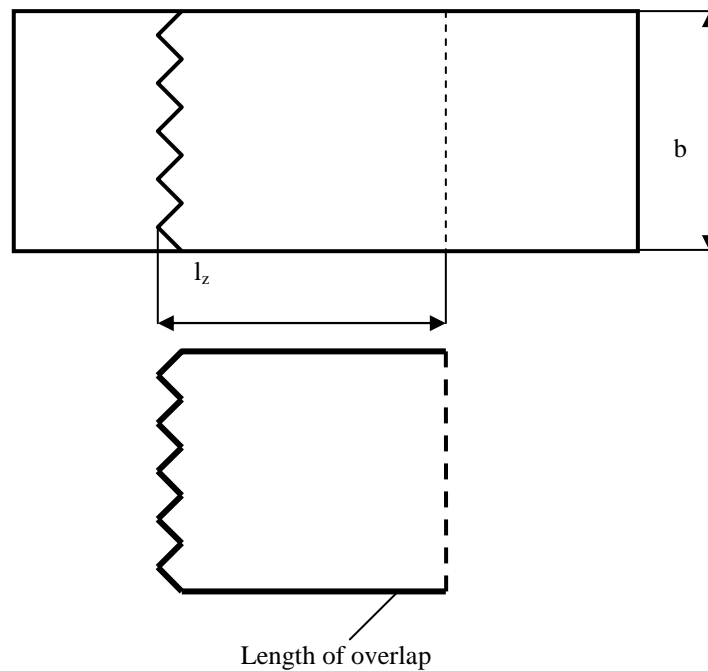

Fig. 5.8. Example of lap joint with increased length of overlap, as used in the experiment

In the experiments changes were observed in the bond-breaking stress as a function of the bond edge line length.

The results representing the ratio of the destructive stress R_t , breaking a bond with increased length of bond edge line, to the destructive stress R_{t0} , breaking a lap

joint of 20 mm x 30 mm ($l_s = 100$ mm) for steel and PA6 aluminium alloy and WK-3 and K-153 adhesives are presented in Fig. 5.9.

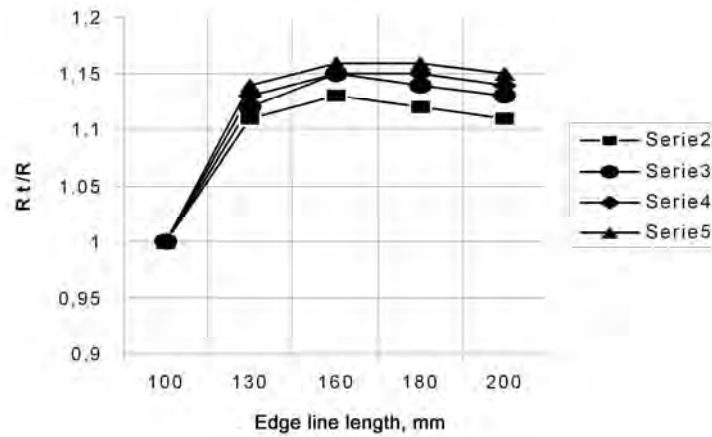

Fig. 5.9. Effect of edge line length on the ratio of the strength of a bond with increased edge line length (R_t) to the strength of a bond with a section of 20x30 mm (R_0): 4 - PA6-PA6 aluminium alloy bond (AW-AlCu4MgSi acc. to PN-EN 573-3:1998), K-153 adhesive, 3 - PA6-PA6 bond (AW-AlCu4MgSi acc. to PN-EN 573-3:1998), WK-3 adhesive, 5 - C45-C45 steel bond, K-153 adhesive, 2 - C45-C45 steel bond, WK-3 adhesive [5.22]

The reported experiment shows that increase in the edge line length of a bond causes an increase in the destructive stress value. This effect should be related with the existence of an adhesive flash on the edge of the bond, increasing the bonding surface area. However, the effect is somewhat greater than could be expected from simple geometric analysis concerning the increase in the bond surface area. It seems that the effect of increase in the destructive stress with increasing length of bond edge line is also influenced by a reduction in the concentration of stress at the ends of the overlap. This is also supported by model analysis with the finite elements method.

5.1.2. Effect of chamfering of overlap ends

Chamfering of overlap edges in adhesive bonds is one of the methods of reducing the coefficient of stress concentration, defined as $\beta = \frac{\tau_{\max}}{\tau_{sr}}$. As follows

from theoretical analysis, model analysis with the method of finite elements, or – ultimately – experimental studies, stress concentration at the ends of bond overlap depends on the coefficient of elongation elasticity of adhesive, bending stiffness of the bonded elements, load conditions, thickness of layer of adhesive, etc.

Chamfering permits a reduction of the bending stiffness of the overlap, and thus a reduction of the coefficient of stress concentration.

Variation of adhesive stiffness along the overlap is beyond consideration for technological reasons, so what remains is the possibility of controlling the stiffness of the bonded materials. This is possible through chamfering the overlap ends. Significant reduction of the coefficient of stress concentration at the ends of bond overlap through the chamfering of the bonded elements has been substantiated and applied in practice wherever there are no serious technological counter-indications. What is significant from the viewpoint of these considerations is only the quantification of that effect as a function of the strength and elastic properties of the adhesive used.

Fig. 5.10 presents schematically a lap joint with chamfered ends.

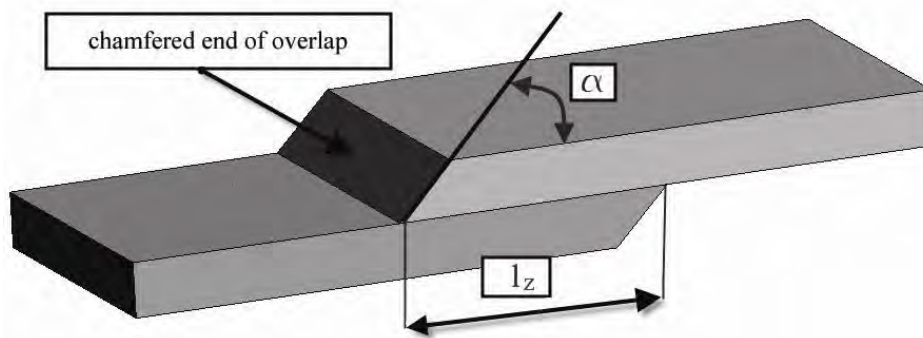

Fig. 5.10. Schematic illustration of chamfering of bond overlap ends

For purposes of verification of the above, a suitable experiment was performed, whose major results are presented in Fig. 5.11.

It should be noted, however, that an epoxy adhesive cured with Z-1 triethylene-tetramine is a “stiff” adhesive. In this case the effect of chamfering is more observable. For adhesives with greater flexibility the effect is not so pronounced.

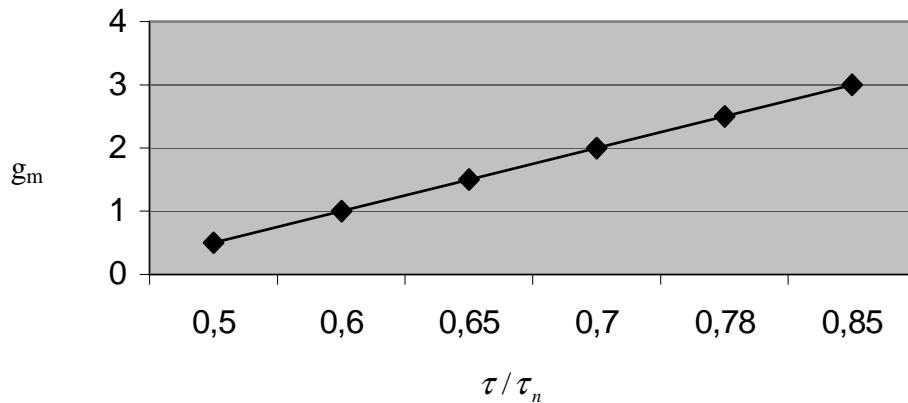

Fig. 5.11. Comparison of shearing strength of a PA6–PA6 lap joint (AW–AlCu4MgSi acc. to PN-EN 573-3:1998) in destructive tests: τ/τ_n – ratio of stress breaking the bond for a joint without chamfering of overlap ends to corresponding stress value for a bond with chamfered overlap ends, adhesive E5/Z-1/10:1, sheet thickness $g_m = 2$ mm, $\alpha = 45^\circ$ [5.22]

The phenomenon of the occurrence of considerable concentration of stresses at the ends of bond overlap inseparably accompanies adhesive lap joints. As follows from theoretical analysis, destructive tests and model analysis with finite elements method, the coefficient of stress concentration depends primarily on the stiffness of the binding medium, characterized by the modulus of rigidity G_k , or longitudinal modulus of elasticity E_k , bending stiffness EJ of bonded materials, thickness of the layer of adhesive, and boundary conditions. Analysis of these factors shows that the possibilities of controlling the coefficient of stress concentration should be sought in changes of bending stiffness EJ . Increasing the thickness of the layer of adhesive usually leads to a decrease in the strength of the bond, so it cannot be the right way to go, and controlling the modulus of elasticity of the adhesive as a function of overlap length is very difficult technologically. In view of this, chamfering of overlap ends is the simplest solution. This is confirmed unquestionably by the results of the experiment. It should be emphasized, however, that the effect of chamfering is significant at small values of thickness of bonded materials, and for steel sheets with thickness above 3 mm the strength increase resulting from the application of overlap ends chamfering is already less than 5%.

It should also be noted that in chamfered bonds the positive effect of adhesive flash virtually disappears, nevertheless the overall effects achieved with this method are highly advantageous.

5.1.3. Effect of adhesive flash at overlap ends

Flash of adhesive at the edge of a lap joint is a typical technological phenomenon in adhesive bonding operations. A schematic illustration of a lap joint with adhesive flash is presented in Fig. 5.12.

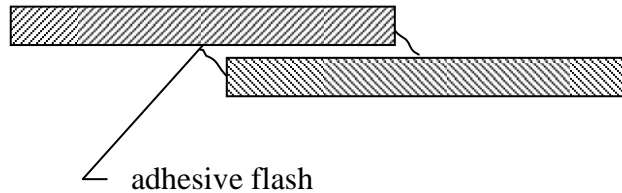

Fig. 5.12. Schematic illustration of adhesive flash at overlap ends

It is frequent for technological process to provide for the removal of adhesive flashes. The effect of the presence of flashes on the stress condition at overlap ends was subjected to finite elements analysis.

It was expected that the existence of the adhesive flash in the area of stress concentration could significantly reduce that concentration. This is confirmed by the results of a numerical experiment, presented in Fig. 5.13.

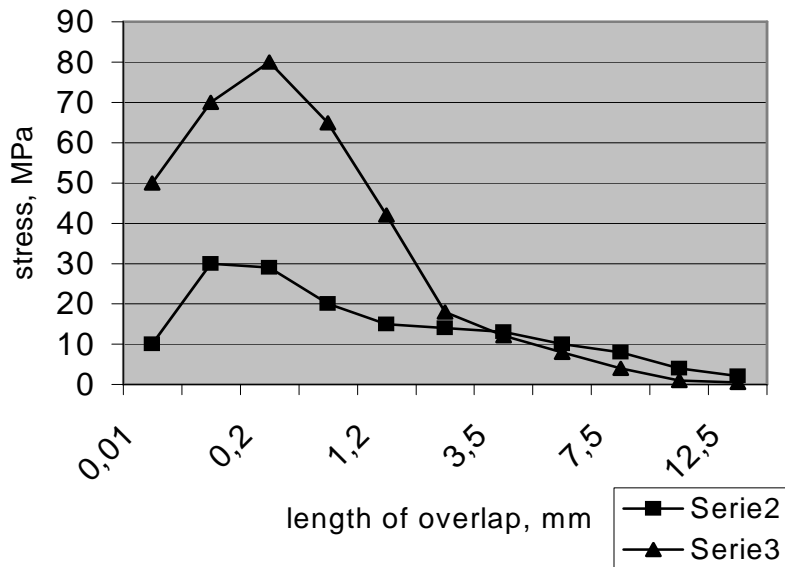

Fig. 5.13. Tangential stress distribution along overlap length: $E_k = 3500$ MPa, $E = 0.7 \times 10^5$ MPa, $g_m = 2$ mm; $P = 2700$ N, $\tau_{sr} = 5.4$ MPa, 2 – lap joint without adhesive flash, 3 – lap joint with adhesive flash [5.22]

As follows from Fig. 5.13, the highest shear stress occurs at a distance of about 0.2 mm from the edge of the joint and its value for the joint with adhesive flash is less than a half of that in the joint without adhesive flash. The presence of the adhesive flash significantly reduces stress concentration. This phenomenon is favourable for the load capacity of adhesive joints of metals. As adhesive flashes are an inseparable element of adhesive bonding operations, the practical conclusion following from the reported experiments is that the flashes should not be treated as technological flaws and should not be removed unless necessary.

The above considerations, and the physical and numerical experiments permit the formulation of the following major conclusions:

1. The analysed edge effects significantly affect the strength of adhesive joints of metals, therefore they may have to be taken into consideration, especially in joints with small dimensions of bonding surface.
2. Favourable effect of chamfering is observed for a variety of materials bonded and of adhesives - from the practical point of view the best effects are obtained by applying chamfering at the angle of $\alpha = 45^\circ$.
3. Adhesive flashes at overlap ends have a positive effect on the distribution of stresses and should not be removed unless it is necessary.
4. The performed experiment involving variation in the edge line length at constant surface area of bond and length of overlap confirmed the significance of the effect of the edge phenomena on the strength of adhesive bonds.

5.2. Strength of face-face (heading) bonds

It is an infrequent occurrence to employ a face-face (heading) adhesive joint subjected to tensile loads. An example of such a joint is presented in Fig. 5.14.

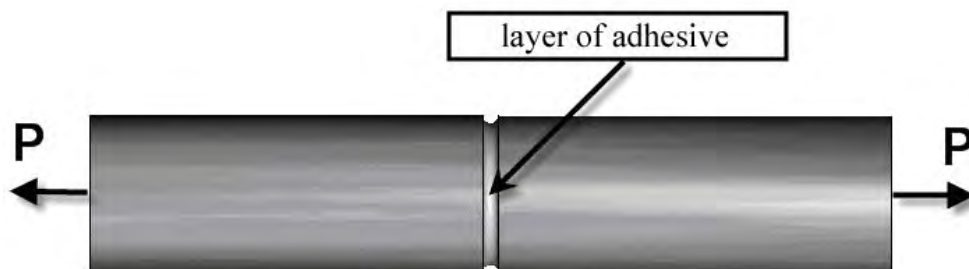

Fig. 5.14. Heading joint with characteristic deformation of the layer of adhesive

Characteristic deformation of the layer of adhesive is the result of large difference in the values of longitudinal modulus of elasticity. This effect causes that in the layer of adhesive immediately adjacent to the bonded material the adhesive

displays an apparently higher value of the longitudinal modulus of elasticity than in the central zone of the layer of adhesive. Adams and Coppendale [5.1] present the following relation

$$E_k' = E_k \frac{1-\nu}{(1+\nu)(1-2\nu)} \quad (5.13)$$

where ν is Poisson coefficient, E_k' – longitudinal modulus of elasticity in the boundary zone of the layer of adhesive, E_k – longitudinal modulus of elasticity in the inner zone of adhesive

Fig. 5.15 presents a heading joint of two sleeves. It is not a recommended type of joint. Unless there are specific design counter-indications, joint types presented in Chapter 4 should rather be used.

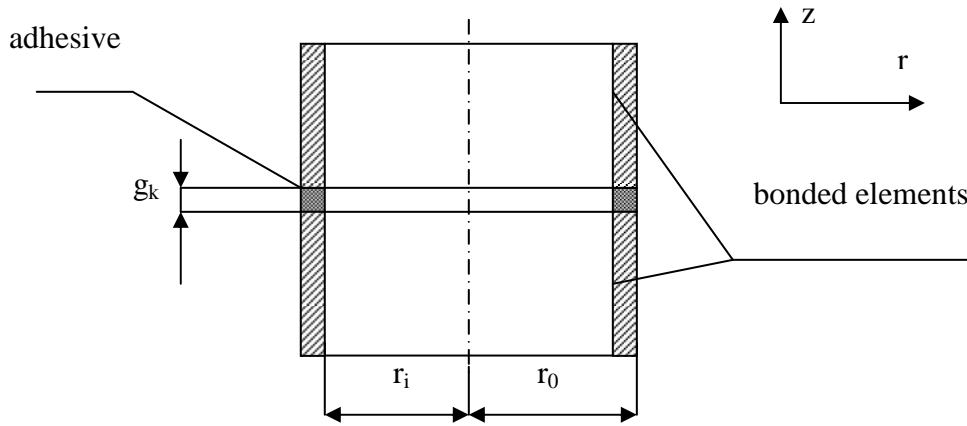

Fig. 5.15. Heading joint of two sleeves

The value of tangential stress on radius r in the case of a heading joint of sleeves is determined as follows [5.1, 5.5, 5.9]:

$$\tau_z = \frac{2T \cdot r}{\pi(r_0^4 - r_1^4)} \quad (5.14)$$

where: T is a tangential force applied on radius r

Circumferential and radial stresses in a heading joint of sleeves loaded with an axial force can be calculated from the relation

$$\sigma_r = \sigma_o = \left(\nu - \frac{E\nu_a}{E_a} \right) \left(\frac{\sigma_z}{1-\nu} \right) \quad (5.15)$$

Heading joints subjected to axial tensile loads are calculated by dividing the value of load force F by the value of the bond surface area S .

$$\sigma = \frac{P}{SK} \quad (5.16)$$

where K is the safety coefficient, σ – permissible tensile breaking stress, also dependent on the adhesive layer thickness .

As a rule, adhesive bonds should not be designed for tensile loads, especially when the bond surface area is not large. Also significant are characteristic boundary conditions. Considerable differences in the values of longitudinal modulus of elasticity E for the adhesive and the bonded material cause that under tensile loading of such a bond the boundary zone of the layer of adhesive, bound with forces of adhesion to the bonded material, behaves differently than the central zone of the layer of adhesive. This is illustrated in Fig. 5.14 in the form of characteristic concavities in the layer of adhesive.

The strength of heading joints, as opposed to lap joints, is proportional to the surface area of the bond. However, we should keep in mind that the edge phenomena related to stress concentration cause that, in the range of small bond surface areas, there is a distinct effect of the bond surface area on the strength of the bond. An example of the results of studies is presented in Fig. 5.16.

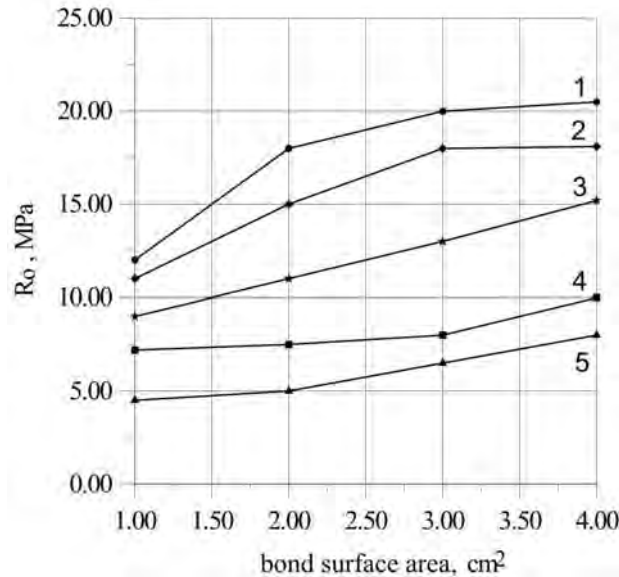

Fig. 5.16. Effect of the size of bond surface area on ultimate tensile strength R_0 ,
 1 – $g_k = 0.15$ mm, 2 – $g_k = 0.3$ mm, 3 – $g_k = 0.5$ mm, 4 – $g_k = 1$ mm, 5 – $g_k = 3$ mm,
 adhesive - E57/PAC/10:8 [5.22]

This effect [$R_o = f(s)$] is clearly visible for adhesive layer thickness values of $g_k = 0.3$ mm and 0.5 mm, that is for typical thickness values used in this type of joints. This supports the influence of the edge effect, including that of stress concentration – for small bond surface areas the influence is distinctly observable.

5.3. Strength of trunnion-sleeve bonds

A typical trunnion-sleeve joint is presented in Fig. 5.17.

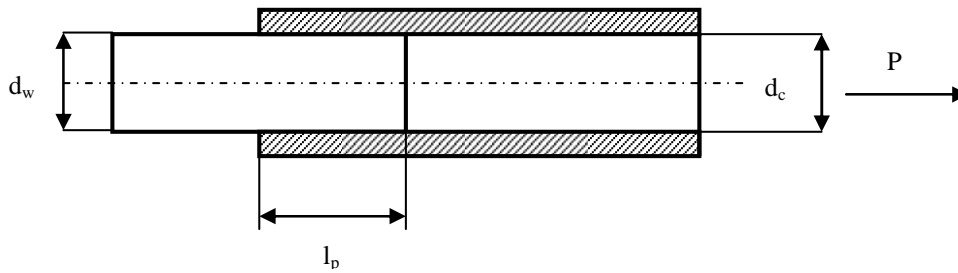

Fig. 5.17. Trunnion-sleeve joint; d_c – sleeve diameter, d_w – trunnion diameter, l – length of joint

Equation describing tangential stress in a trunnion-sleeve joint loaded with force P can be presented as follows [5.11]:

$$\tau(x) = 2C[\cosh \omega x + \chi \cosh \omega(l - x)]P \quad (5.17)$$

$$\text{where: } C = \frac{G_k}{\omega g_k E_1 F_1} \frac{e^{\omega l}}{e^{2\omega l} - 1}, \quad \omega = \sqrt{\frac{\pi D G_k}{C_z g_k}}, \quad \chi = \frac{E_1 F_1}{E_2 F_2}$$

$E_1 F_1$ – longitudinal rigidity of internal element, $E_2 F_2$ – longitudinal rigidity of external element

$$C_z \text{ – equivalent rigidity defined by the relation } C_z = \frac{E_1 F_1}{1 + \frac{E_1 F_1}{E_2 F_2}}$$

For $x=0 \rightarrow \tau_{(0)} = 2C(1 + \chi \cosh \omega l) \leq \frac{\tau_{dop}}{K}$, where K is the safety coefficient

The coefficient of stress concentration can be calculated from the relation

$$\alpha_k = \frac{1}{\sqrt{g_k R}} \sqrt{\frac{G_k e^{\omega l} + 1}{G e^{\omega l} - 1}} \quad (5.18)$$

In a situation where a trunnion-sleeve joint is loaded with a moment

$$\tau(x) = \frac{G_k R e^{\omega x} + e^{\omega(1-x)}}{g_k (1 + e^{\omega l})} \varphi_0 \quad (5.19)$$

where $\omega = \frac{2}{\sqrt{g_k R}} \sqrt{\frac{G_k}{G}}$

$$\varphi(x) = \frac{e^{\omega x} + e^{\omega(1-x)}}{1 + e^{\omega l}} \varphi_0, \quad \varphi_0 = \varphi(0) \quad (5.20)$$

$$\tau_{\max} = \tau_0, \text{ dla } x = 0$$

$$\tau_0 = \frac{R}{g_k} G_k \varphi_0 \leq \frac{\tau_{dop}}{K} \quad (5.21)$$

The presented analysis from the viewpoint of strength permits the formulation of the following general conclusions:

- recommended thickness of adhesive bond (0,13 – 0,15)mm,
- trunnion length $l = (11 – 13)$ mm,
- increase in trunnion length causes increased stress concentration,
- variable loads are better transmitted by adhesive bonds with greater thickness, which is related to better shock absorbing properties.

Presumably, trunnion-sleeve adhesive joints will be more and more commonly used in machine building. This is related to the good shock-absorbing properties of the layer of adhesive and permits the forecast of increasing interest in the application of such bonds in gear or chain drive units, etc.

5.4. Tear-off strength

Tearing-off or peeling is a characteristic type of loading of an adhesive bond, characterized by considerable stress concentration along the peel line. An example of such a load is presented schematically in Fig. 5.18.

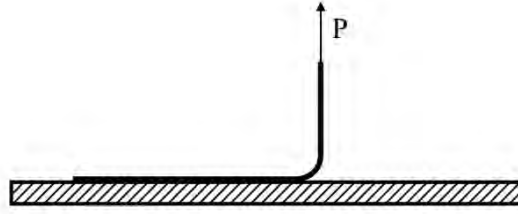

Fig. 5.18. Example of adhesive bond with peel load

For the case presented in Fig. 5.18 the maximum peel stress can be calculated from the relation [5.9]

$$\sigma_{\max} = \frac{M_g}{b} \sqrt{\frac{12E_k}{Eg_m^3 g_k}} + \frac{P\sqrt{2}}{b} \sqrt[4]{\frac{12E_k}{Eg_m^3 g_k}} \quad (5.22)$$

where b – width of bond, M_g – bending moment.

Assuming that the component related to force P is of a lower order compared to the moment, a reduced relation can be adopted

$$M_g = \sigma_n b \sqrt{\frac{Eg_m^3 g_k}{12E_k}} \quad (5.23)$$

As follows from the above relation, the thickness of bonded elements has a considerable effect on the value of the bending moment. It should also be kept in mind $\sigma_n = f(\delta_k)$.

The value of force P that causes de-cohesion of the bond depends also on the width b of the bond. A simplified indicator defining the ability of a bond to transmit peel loads can be the unit value of the peel force which can be determined from the relation

$$t_i = \frac{P}{b} \quad (5.24)$$

In the case of adhesive joints subjected to peel loads, adhesives characterized by high flexibility are used.

5.5. Compound cases of bonded joint loading

5.5.1. Resistance to cracking

The resistance to cracking, rarely analysed in the assessment of adhesive bonds, in certain situation may have a significant effect on the safety of structures [5.13, 5.18, 5.22]. This concerns primarily adhesives with relatively higher values of the longitudinal modulus of elasticity. Even adhesives with considerable elasticity as a result of the processes of ageing may gradually lose their resistance to cracking. The assumption of continuity and homogeneity of bonds within the adhesive and cohesive areas is risky, mainly for the following reasons:

- surfaces prepared for adhesive bonding are not uniform in terms of energy; local changes in sorptive properties may cause changes in the properties of cured adhesive,
- during adhesive preparation, especially chemically cured, it is very difficult to obtain thorough mixing of the curing agent with the other components of the adhesive, which causes a non-uniform degree of crosslinking, and in an extreme case may lead to the appearance of a “thin spot”, i.e. an irregularity where the adhesive is semi-liquid,
- during adhesive preparation frequently air bubbles are inadvertently introduced into the composition and not fully removed during the curing process; they remain then in the cohesive zone or migrate to the phase boundary and, joining with gas molecules at the bottom on micropores of the bonded surfaces, may form unbonded spots, frequently of considerable dimensions.

Observations of the process of adhesive bond breaking under static load show that usually the process of de-cohesion has a violent character, irrespective of the elastic properties of the adhesive. Cured adhesive, in the form of a thin coat and supported on both sides by the joined surfaces of bonded elements, has higher stiffness than the same adhesive cast in the form of a classic dumbbell. The problem of catastrophic character of cracking of adhesive bonds of metals can, in some cases, be an important determinant in the assessment of safety margin of bonded structures. Fig. 5.19 presents typical cases of non-homogeneity in the adhesive and cohesive zones of an adhesive bond.

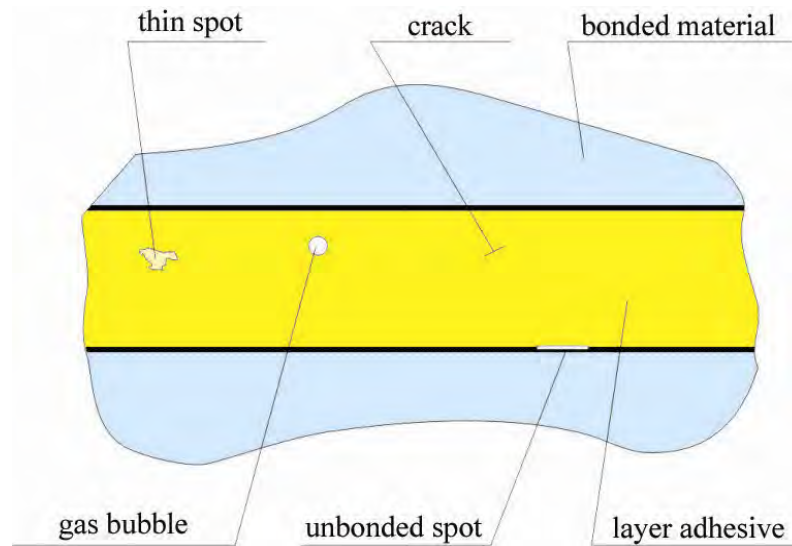

Fig. 5.19. Typical examples of non-homogeneity in adhesive and cohesive zones of an adhesive bond

Unbonded spots and gas bubbles in the cohesive zone may act as stress concentrators and significantly affect the operational characteristics of adhesive bonds.

Gas bubble in the cohesive zone

The analysis of adhesive bonds resistance to cracking is presented on the basis of a monograph [5.22]. Let us assume that in the neighbourhood of a gas bubble with radius R , under the effect of load σ , there formed a crack in the form of a circular ring with radii R and $R + a$. The front of the crack is surrounded with a toroidal plastic area with radius r_{pl} , as presented schematically in Fig. 5.20.

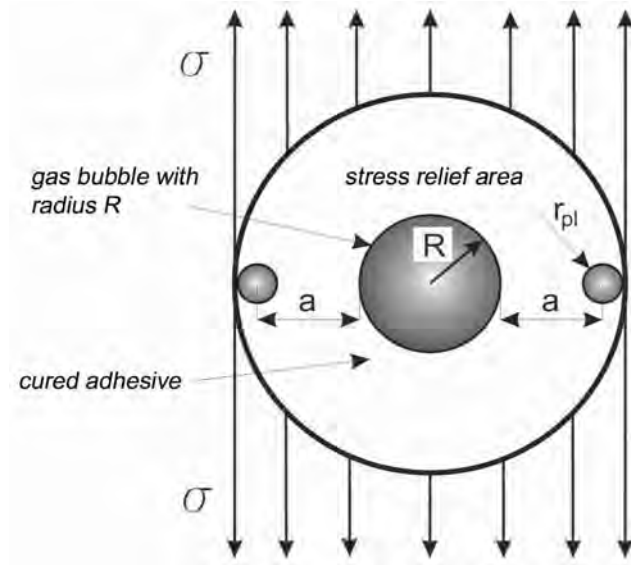

Fig. 5.20. Schematic presentation of the zone around a gas bubble

Thus, around the gas bubble there forms an area of stress relief, in the form of a sphere with radius $R+a+r_{pl}$. If we treat it as an isolated area, we can represent the balance of energy processes occurring in the course of cracking. In the homogeneous medium subjected to load σ potential elastic energy U_o is accumulated. When the crack is formed, a part of that energy is released in the form of relief energy U_{od} . This energy partially remains in the form of surface energy U_p , and another part is used for the work of plastic deformation U_{pl} in the toroidal surroundings of the crack edge. The balance of energy processes, therefore, has the form [5.25]

$$U = U_o - U_{od} + U_p + U_{pl} \quad (5.25)$$

The specific elastic energy (energy per unit of volume) is $\Phi = \sigma^2/2E_k$. Assuming that, for the gas bubble, $E = 0$ (E – longitudinal modulus of elasticity, σ – stress, as in Fig. 5.21), we obtain the relief area in the form of a sphere with radius $R + a + r_{pl}$ with a hollowed out sphere of radius R inside. The relief energy is, therefore

$$U_{od} = \Phi \cdot V_{od} = \frac{\sigma^2}{2E_k} \left[\frac{4}{3} \pi (R + a + r_{pl})^3 - \frac{4}{3} \pi R^3 \right] \quad (5.26)$$

where: V_{od} – volume of the relief area.

The surface energy is calculated from the relation

$$U_p = 2 F \alpha \quad (5.27)$$

where: F – surface area of the crack, α – specific surface area.

In the case under consideration, the surface area of the crack is a circular ring with the outer radius $R + a$ and inner radius R . Surface energy, therefore, has the value

$$U_p = 2 F \alpha = 2[\pi(R + a)^2 - \pi R^2] \alpha = 2\pi[(R + a)^2 - R^2] \alpha \quad (5.28)$$

The most important element in the calculation of energy of plastic deformations is the determination of the plastic area. In linear mechanics of cracking [5.43] the cracking intensity coefficient K_c is used for this purpose. If the plastic deformation area attains a size of the order of the crack dimensions (which may happen in the case of adhesives), coefficient K_c ceases to have physical sense. For the determination of the radius of the plastic area around the apex of the crack the relation formulated by M.P. Wnuk was employed [5.43]

$$r_{pl} = (R + a) \left[1 - \left(\frac{\sigma}{R_{ek}} \right)^2 \right]^{-0.5} - 1 = (R + a) \left(\frac{R_{ek}}{(R_{ek}^2 - \sigma^2)^{0.5}} - 1 \right) \quad (5.29)$$

The energy of plastic deformations U_{pl} was calculated from the relation

$$U_{pl} = R_{ek} \cdot \varepsilon_e \cdot V_t \quad (5.30)$$

where: $R_{ek} \cdot \varepsilon_e$ – specific plastic energy, R_{ek} – limit of plasticity of the adhesive, ε_e – relative plastic elongation, $V_t = 2\pi^2 (R + a) r_{pl}^2$ – volume of the toroidal plastic area as in Fig. 5.21. Therefore, the energy of plastic deformation assumes the form

$$U_{pl} = R_{ek} \cdot \varepsilon_e \cdot 2\pi^2 (R + a)^3 \left(\frac{R_{ek}}{(R_{ek}^2 - \sigma^2)^{0.5}} - 1 \right)^2 \quad (5.31)$$

Ultimately, the sought energy equation, after the inclusion of the argument (5.29) in the relation (5.26), assumes the form:

$$\begin{aligned}
 U = U_0 - \frac{\sigma^2}{2E_k} \frac{4}{3} \pi (R+a) \left(\frac{R_{ek}}{(R_{ek}^2 - \sigma^2)^{0.5}} \right)^3 - \frac{4}{3} \pi R^3 + \\
 2\pi \left[(R+a)^2 - R^2 \right] \alpha + \\
 + R_{ek} \cdot \varepsilon_e \cdot 2\pi^2 (R+a)^3 \left(\frac{R_{ek}}{(R_{ek}^2 - \sigma^2)^{0.5}} - 1 \right)^2
 \end{aligned} \tag{5.32}$$

In a situation where the size of the crack exceeds the critical value, cracking (brittle) takes place spontaneously, without any energy input from outside, and then the critical value (R+a) corresponds to the extreme (maximum) of the function of energy (5.32):

$$\begin{aligned}
 \frac{\delta U}{\delta (R+a)} = -2 \frac{\sigma^2}{E_k} \pi \left(\frac{R_{ek}}{(R_{ek}^2 - \sigma^2)^{0.5}} \right)^3 (R+a)^2 + 6(R+a)^2 R_{ek} \cdot \varepsilon_e \cdot \pi^2 \\
 \left(\frac{R_{ek}}{(R_{ek}^2 - \sigma^2)^{0.5}} - 1 \right)^2 + 4\pi \cdot \alpha (R+a)
 \end{aligned} \tag{5.33}$$

Equating to zero the value of the first derivative from the relation (5.33) we can calculate the critical value of R+a

$$R+a = \frac{2\alpha}{\frac{\sigma^2}{E_k} \left(\frac{R_{ek}}{(R_{ek}^2 - \sigma^2)^{0.5}} \right)^3 - 3R_{ek} \cdot \varepsilon_e \cdot \pi \left(\frac{R_{ek}}{(R_{ek}^2 - \sigma^2)^{0.5}} - 1 \right)^2} \tag{5.34}$$

We should take note of the conclusions from the relation obtained. Assuming that $\alpha = 0$ we can determine the critical dimensions of the gas bubble at which crack initiation occurs. The value of R_{kryt} is:

$$R_{kryt} = \frac{2\alpha}{\frac{\sigma^2}{E_k} \left(\frac{R_{ek}}{(R_{ek}^2 - \sigma^2)^{0.5}} \right)^3 - 3R_{ek} \cdot \mathcal{E}_e \cdot \pi \left(\frac{R_{ek}}{(R_{ek}^2 - \sigma^2)^{0.5}} - 1 \right)^2} \quad (5.35)$$

It is also worth noting that for a value of σ that is low with relation to R_{ek} the argument

$\frac{R_{ek}}{(R_{ek}^2 - \sigma^2)^{0.5}}$ tends to one. As a consequence, the relation (5.35) tends with the

accuracy of the multiplicative constant to the form of the Griffith formula [5.20], the basic formula in the liner mechanics of cracking. There is one more important conclusion that follows from the relation (5.35). In a situation when the denominator in the relation (5.35) tends to zero, R_{kryt} tends to infinity. This means that it is possible to calculate, from the relation, the critical value of relative plastic elongation beyond which brittle cracking will not take place irrespective of the dimensions of the gas bubble. In accordance with the essence of considerations, we are considering such a range of values of the function defined by the formula (5.35) for which it assumes positive values and is a decreasing function of the variable σ . With such boundary conditions, the critical values of the gas bubble dimensions should only be sought in a case when

$$\mathcal{E}_e \leq \min(\mathcal{E}_1, \mathcal{E}_2) \quad (5.36)$$

where:

$$\mathcal{E}_1 = \frac{\sigma^2}{3E_k \cdot \pi (R_{ek}^2 - \sigma^2)^{0.5}} \frac{R_{ek}^2}{\left[R_{ek} - (R_{ek}^2 - \sigma^2)^{0.5} \right]^2} \quad (5.37)$$

$$\mathcal{E}_2 = \frac{1}{6E_k \cdot \pi (R_{ek}^2 - \sigma^2)^{0.5}} \frac{2R_{ek}^3 + \sigma^2 R_{ek}}{\left[R_{ek} - (R_{ek}^2 - \sigma^2)^{0.5} \right]^2} \quad (5.38)$$

Assuming for a specific adhesive the value of α and \mathcal{E}_{pl} we can determine the critical values of the gas bubble radius in the function of σ/R_{ek} . Such calculations were performed, and an experiment was undertaken, the objective of which was the comparison of the calculated values of R_{kryt} with the true values, simulated in the experiment. Selected results of the experiment are presented in Fig. 5.21. For the determination of the critical values of radius the following relation was applied:

$$R_{kryt} = \frac{JE}{\pi\tau^2} \quad (5.39)$$

The critical value of integral J was determined in the experiment in accordance to the relevant standard [5.28]

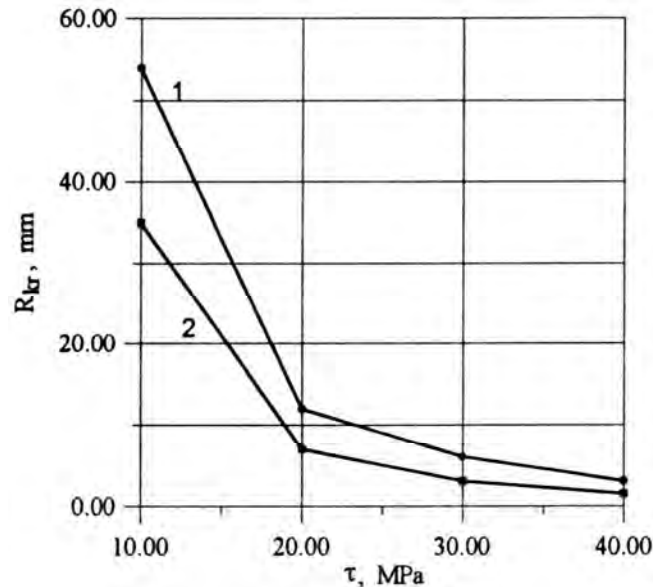

Fig. 5.21. Relation $R_{kryt} = f(\tau)$ for $E_k = 3000$ MPa, 1 – $J = 5.65$ N/mm, 2 – $J = 3.65$ N/mm [5.22]

The experiment carried out indicates a considerable divergence between the critical values of gas bubble radius determined from the classical and modified Griffith analysis and those determined in the experimental study through the determination of the critical value of integral J. The comparison, however, concerns the average values of stress adopted for the analysis, while stresses at overlap ends are sometimes several times higher and it is those stresses that should be subjected to analysis. Figure 5.21 can be useful for the estimation of critical dimensions of instances of non-homogeneity in the adhesive.

Unbonded spot

The occurrence of unbonded spots is a typical technological flaw. Unbonded spots are a frequent occurrence despite the observance of strict technological discipline, even in fully automated systems. This may be related with air bubbles, enclosed in micropores, which can join one another under specific conditions. Such

a situation can take place irrespective of what type of clamping pressure is applied – negative or positive pressure.

Let us assume that in an unloaded adhesive bond there is an unbonded spot as shown in Fig. 5.22.

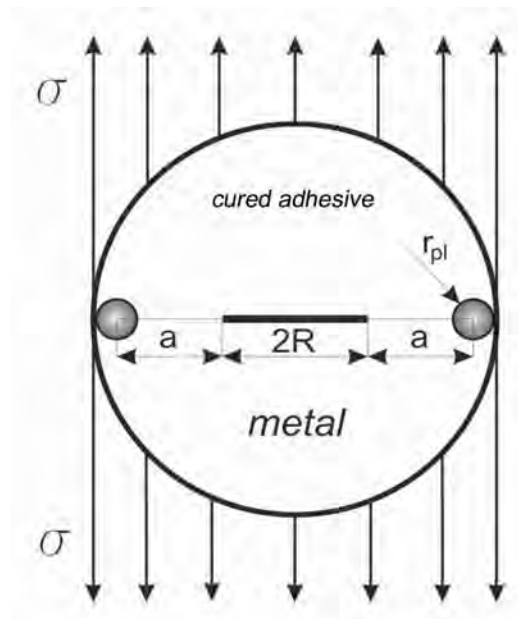

Fig. 5.22. Circular unbonded spot with indicated relief area and toroidal zone of plasticization

Under the effect of applied load σ the radius of the non-homogeneity (unbonded spot) R increases to $R+a$. For simplification, it was accepted that the thickness of the bond is sufficient to cover the whole relief area for the adhesive, i.e. $g_k \geq R+a+r_{pl}$. Adopting, for simplicity, the principle of identical deformations at the phase boundary, the radius of the plastic zone was determined after M.P. Wnuk [5.43]. The value of R_{ek} was adopted for the adhesive, assuming that the processes of de-cohesion in adhesive joints of metals occur as a rule within the adhesive layer or at the phase boundary. The relief energy, after going through the line of consideration like that in the case of gas bubble, will now take the following form (index „m” related to the metal, index „k” to the adhesive):

$$\begin{aligned}
 U_{ad} &= \frac{\sigma^2}{2E_m} \cdot \frac{1}{2} \cdot \frac{4}{3} \pi (R + a + r_{pl})^3 + \frac{\sigma^2}{2E_k} \cdot \frac{1}{2} \cdot \frac{4}{3} \pi (R + a + r_{pl})^3 = \\
 &= \frac{\sigma^2}{3} \cdot \pi (R + a + r_{pl})^3 \left(\frac{1}{E_m} + \frac{1}{E_k} \right)
 \end{aligned} \tag{5.40}$$

Assuming that in an adhesive bond there exists a distinct phase boundary between the adhesive and the bonded materials (we leave out from our consideration cases of adhesive joints in which diffusive processes play an important role in the formation of the joint – in metal bonding such cases do not occur), the component of surface energy in the energy balance was substituted by the work required to separate the adjacent phases, that is by the work of adhesion W_a on the surface of a circular ring with the radii R and $(R+a)$

$$U_p = W_a \cdot \pi [(R + a)^2 - R^2] \tag{5.41}$$

The energy of plastic deformation U_{pl} was calculated in the same manner as before, assuming that the area of plasticization is the same in the layer of adhesive and in the metal (note should be taken that this is a simplification adopted to facilitate the calculations)

$$\begin{aligned}
 U_{pl} &= R_{em} \cdot \varepsilon_v \cdot \pi^2 (R + a)^3 \cdot \left(\frac{R_{ek}}{(R_{ek}^2 - \sigma^2)^{0.5}} - 1 \right)^2 + \\
 &+ R_{ek} \cdot \varepsilon_v \cdot \pi^2 (R + a)^3 \cdot \left(\frac{R_{ek}}{(R_{ek}^2 - \sigma^2)^{0.5}} - 1 \right)^2 = \\
 &= \varepsilon_v \cdot \pi^2 (R + a)^3 \cdot \left(\frac{R_{ek}}{(R_{ek}^2 - \sigma^2)^{0.5}} - 1 \right)^2 (R_{em} + R_{ek})
 \end{aligned} \tag{5.42}$$

Therefore, the energy equation assumes the form

$$\begin{aligned}
 U = & U_a - \frac{\sigma^2 \cdot \pi}{3} \cdot (R+a)^3 \cdot \left(\frac{R_{ek}}{(R_{ek}^2 - \sigma^2)^{0.5}} \right)^3 \cdot \left(\frac{1}{E_m} + \frac{1}{E_k} \right) + W_a \cdot \pi \cdot [(R+a)^2 - R^2] + \\
 & + \varepsilon_e \cdot \pi^2 \cdot (R+a)^3 \cdot \left(\frac{R_{ek}}{(R_{ek}^2 - \sigma^2)^{0.5}} - 1 \right)^2 \cdot (R_{vm} + R_{ek})
 \end{aligned}
 \tag{5.43}$$

Following a procedure analogous to that employed before, after differentiating energy U (5.43) with relation to (R+a) and after suitable transformations, we obtain

$$R_{kryt} = \frac{2W_a}{\sigma^2 \cdot \left(\frac{1}{E_m} + \frac{1}{E_k} \right) \left(\frac{R_{ek}}{(R_{ek}^2 - \sigma^2)^{0.5}} \right)^3 - 3\varepsilon_e \cdot \pi \left(\frac{R_{ek}}{(R_{ek}^2 - \sigma^2)^{0.5}} - 1 \right)^2 \cdot (R_{vm} + R_{ek})}
 \tag{5.44}$$

Adopting the boundary conditions that the function (5.44) is to assume positive values and that it is to be decreasing function of the variable σ we obtain the critical values of relative plastic deformation above which brittle cracking will not occur irrespective of the value of the radius of the unbonded spot. With these assumptions the values of ε_e are as follows:

$$\varepsilon_e < \min(\varepsilon_1, \varepsilon_2)
 \tag{5.45}$$

$$\varepsilon_1 = \frac{\left(\frac{1}{E_m} + \frac{1}{E_k} \right) \frac{\sigma^2 R_{ek}^3}{(R_{ek}^2 - \sigma^2)^{3/2}}}{3\pi (R_{ek} + R_{vm}) \left(\frac{R_{ek}}{(R_{ek}^2 - \sigma^2)^{0.5}} - 1 \right)^2}
 \tag{5.46}$$

$$\varepsilon_2 = \frac{\left(\frac{1}{E_m} + \frac{1}{E_k} \right) \frac{2R_{ek}^4 + R_{ek}^2 \cdot \sigma^2}{R_{ek}^2 - \sigma^2}}{6\pi(R_{cm} + R_{ek}) \left(\frac{R_{ek}}{(R_{ek}^2 - \sigma^2)^{0,5}} - 1 \right)} \quad 5.47$$

It is worth noting that for $E_m = E_k$ and $R_m = R_{ek}$, which occurs in the bonding of many polymer materials, the relation (5.44) assumes the same form as in (5.35), the difference being that 2α is replaced by $2W_n$. Surface energy is closely related both with the work of adhesion and with the work of cohesion. Unit work of cohesion is equal to 2α . The work of adhesion is equal to the work of cohesion only in the case of ideal wetting of the bonded materials by the adhesive, that is in a situation when the wetting angle equals zero. On actual surfaces such a situation never occurs, hence the unit work of cohesion is always greater than the unit work of adhesion. It should also be noted that in lap-type adhesive joints there occur variable stresses along the length of overlap, so unbonded spots of gas bubbles of the same size will produce various effects on the load capacity of the structure depending on their location in the bond.

The mechanical properties of a layer of adhesive weakened by the occurrence of non-homogeneity can be described by means of the Maxwell model [5.12, 5.22, 5.31], for which total deformation is the sum of elastic and viscous deformations. Our own experiments as well as published works [5.31] indicate the applicability of the model for the description of the behaviour of deformed adhesive bond under load. The rheological equation for the model is as follows:

$$\frac{d\gamma}{dt} = \frac{1}{G} \frac{d\gamma}{dt} + \frac{\tau}{\eta} \quad (5.48)$$

where: $\gamma = \text{tg}\gamma$ – angle of non-dilatational strain (equality adopted for small values of angle γ), η – dynamic viscosity. Non-homogeneities existing in the layer of adhesive weaken the load transmission capability and can be accounted for in the above expression by the term of damage [5.31]

$$(1 - \psi) \frac{d\gamma}{dt} = \frac{1}{G} \frac{d\gamma}{dt} + \frac{\tau}{\eta} \quad (5.49)$$

The damage term can be determined experimentally, for example with the method of acoustic emission. Then the damage term can be defined as follows:

$$\psi = 1 - \rho_c \quad (5.50)$$

where ρ_c is the coefficient of emission determined as the ratio of the value of stress at which the first micro-cracks appear to the value of the destructive stress.

Assuming proportional relation between the dimensions of the non-homogeneity and the angle of non-dilatational strain, and boundary conditions of $\tau = \tau(\gamma)$, for $\gamma = 0$

$\rightarrow \tau = 0$ we can obtain the equation

$$\tau = \frac{G}{\gamma} \left\{ \left(1 + \frac{\omega}{\lambda} \right) [1 - \exp(-\lambda\gamma) - \omega\gamma] \right\} \quad (5.51)$$

where: $\lambda = \frac{G}{\frac{d\gamma}{dt}\eta}$ was adopted as a structural coefficient, $\omega = \frac{\psi}{\gamma - \gamma_{crit}}$ - damage

parameter, γ_{crit} - critical angle of non-dilatational strain at which bond destruction occurs, η - dynamic viscosity. The values of ω and λ can be determined from the diagram of $\tau = \tau(\gamma)$ from two pairs of values

$$\tau_1, \gamma_1 \text{ and } \tau_2, \gamma_2.$$

It should be stated, however, that experimental verification, especially of the postulate of proportionality of relation between the size of the non-homogeneity and the angle of non-dilatational strain, is not unique due to excessive scatter of results.

The experiment performed with the use of the critical integral J, determined in experimental studies for the epoxy adhesive E5/Z-1/10:1, was utilized for the determination of the critical dimensions of non-homogeneity of bonds. The adhesive used is rather "stiff", so assuming that the value of plasticization around the front of the crack is less than the size of the crack, and that there occurs planar state of stress and the anti-planar state of stress does not, we can write:

$$J_{IC} = \frac{1}{E} \left[\left(\sigma \sqrt{\pi R_{kryt}} \right)^2 + \left(\tau \sqrt{\pi R_{kryt}} \right)^2 \right] \quad (5.52)$$

For $\sigma \rightarrow 0$ (high bending stiffness of the bonded elements) it is possible to calculate the critical dimensions of unbonded spot according to the relation (5.39).

Using the relation (5.39), after experimental determination of the critical value of integral J it is possible to estimate the critical dimensions of unbonded spot like in the case of gas bubble (Fig. 5.21)

5.5.2. Thermal shock fatigue

Adhesive joints subjected to static loads, operated under conditions of exposure to atmospheric effects, are subject to diurnal thermal cycle. A cause of changes in the temperature of a joint can also be the conditions of its operation. A typical case is aerospace – at the moment of takeoff of a plane the temperature above the runway can be dozens of degrees Celsius above zero, and several minutes after takeoff, when the plane has reached a certain altitude, ambient temperature may be about forty degrees Celsius below freezing. In view of the considerable differences in the values of thermal expansion coefficient of the bonded materials and the adhesive, we should expect variable thermal loads of considerable value [5.39]. These problems are not addressed in the research literature. There is also a lack of standardisation in the range of testing methodology relating to fatigue phenomena resulting from thermal loads.

The fairly modest experiments conducted in this area by this author indicate that the phenomenon of thermal fatigue has a statistically significant effect on the strength of adhesive joints. The experiments were made for steel and aluminium alloy samples with lap and heading joints. Two types of epoxy adhesives were used - E5/Z-1/10:1 (a „stiff” adhesive) and E5/PAC/10:8 (an adhesive with increased elasticity). The character of the cycle of thermal effect is presented in Fig. 5.23, and some results of the experiment in figures 5.24 and 5.25.

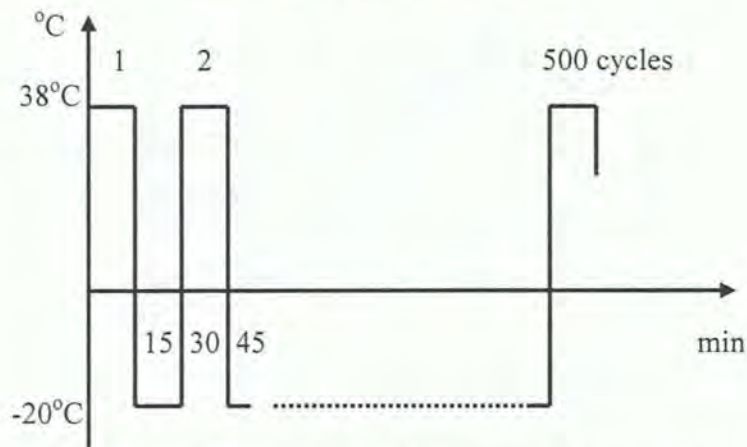

Fig.5.23. Course of the test cycle in experiments on thermal fatigue

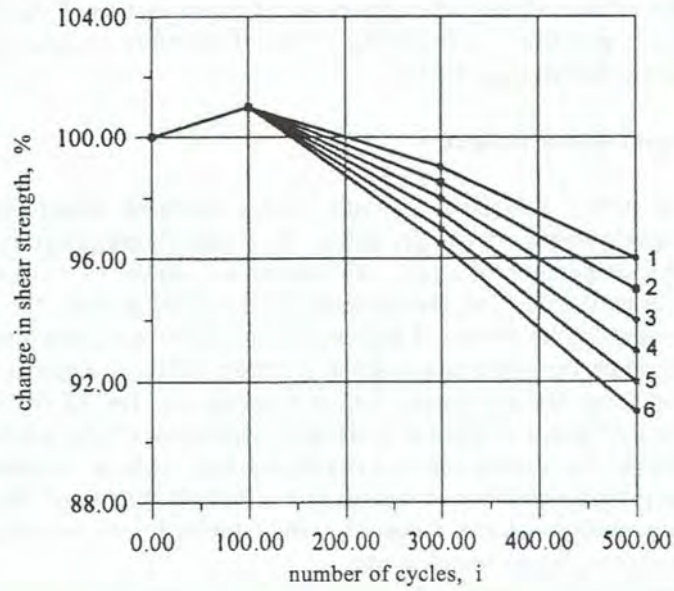

Fig. 5.24. Changes in the strength of lap joints under the effect of thermal shock ageing, 1 – E5/Z-1/10:1, 2 – E5/PAC/10:8 [5.22]

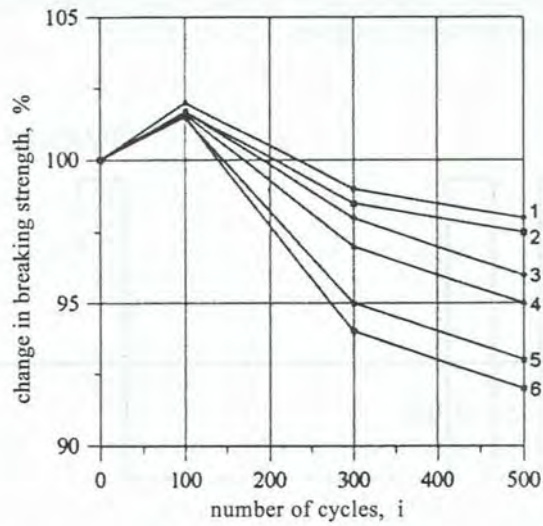

Fig. 5.25. Changes in the strength of heading joints under the effect of thermal shock ageing, 1 – E5/Z-1/10:1, 2 – E5/PAC/10:8 [5.22]

More important observations resulting from analysis of the effects of ageing with thermal shock as follows:

1. In the initial period of ageing a slight increase in strength was observed, probably an effect of after-bake of the bond; the bonds were cured at ambient temperature.
2. After 500 cycles of thermal load as in Fig. 5.23 a slight decrease in strength was observed.
3. After the ageing no significant differences in the strength of joints were observed with relation to the type of adhesive used (considerable differences in stiffness when cured).
4. Lap joints and heading joints display similar responses to the process of ageing with thermal shock.

The experiments carried out indicate, however, that the results obtained cannot be directly applied to other conditions, e.g. diurnal changes in temperature, as those differ in the conditions of stress relaxation, in amplitudes of temperature changes, etc. What the results do indicate is that the problem is significant and should be included in serious analyses of strength.

5.5.3. Eccentricity of load

This type of loading relates rather to heading joints with high bending rigidity of the elements bonded. A schematic presentation of a heading joint loaded in this manner is given in Fig. 5.26.

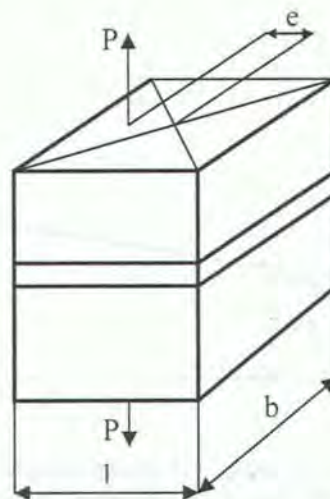

Fig. 5.26. Heading joint under eccentric load

The highest normal stresses are defined by the relation [5.9]

$$\sigma_{\max} = \frac{P}{b.l} \left(1 + \frac{e}{l} \right) \quad (5.53)$$

In the case of joining the face surfaces of two cylinders with diameter d the relation is as follows [5.9]:

$$\sigma_{\max} = \frac{4P}{\pi.d^2} \left(1 + 8 \frac{e}{d} \right) \quad (5.54)$$

where: d – cylinder diameter, P – force loading the joint, e – eccentricity of load.

The above relations are true with the assumption of high rigidity of the elements joined, and such – most frequently - is the case with heading joints.

5.6. Creep in bonded joints

Creep is most generally defined as a phenomenon describing an increase in deformation in time under constant load. As a rule, structural materials creep according to a conventional schematic as presented in Fig. 5.27.

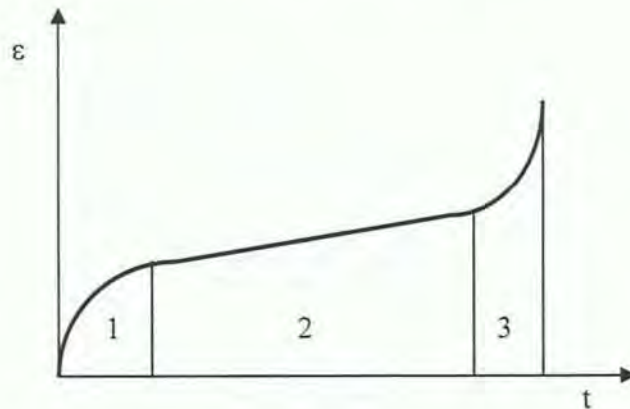

Fig. 5.27. Typical course of creep of structural materials: 1 – initial, non-linear phase of creep, 2 – steady creep phase, 3 – accelerated creep, to breaking point

It is also worthwhile to mention a phenomenon that in a sense is opposite to that of creep, i.e. the phenomenon of stress fading that occurs at constant strain. It is the phenomenon of relaxation.

Most frequently, for the description of the behaviour of adhesive joints under load we use the Maxwell or Voigt models [5.40, 5.41].

The Maxwell model can be described with the equation:

$$\frac{d\gamma_z}{dT} = \frac{1}{G_1} \left[\frac{d\tau}{dT} \right] + \frac{\tau}{\eta_1} \quad (5.55)$$

where: η_1 - coefficient of viscosity.

Graphically the model can be presented as shown in Fig. 5.28.



Fig. 5.28. Graphic presentation of the Maxwell model

The constitutive equation of the Voigt model, also known as the Kelvin-Voigt model, can be described as follows:

$$\sigma = E\varepsilon + \lambda \dot{\varepsilon} \quad (5.56)$$

Graphic interpretation of the Voigt model is presented in Fig.5.29.

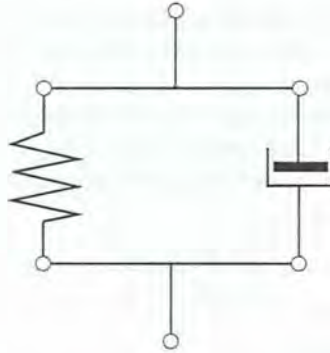

Fig. 5.29. Graphic interpretation of the Voigt model

The model of Burgers body [5.33] is formed through series joining of the models of Maxwell and Voigt. It is an interesting model for qualitative description of phenomena in viscoelastic materials. The equation describing the model has the form:

$$\frac{d^2\tau}{dt^2} + \left[\frac{G_1}{\eta_2} + \frac{G_1}{\eta_1} + \frac{G_2}{\eta_2} \right] \frac{d\tau}{dt} + \left[\frac{G_1 G_2}{\eta_1 \eta_2} \right] \tau = G_1 \left[\frac{d^2\gamma}{dt^2} \right] + \left[\frac{G_1 G_2}{\eta_2} \right] \frac{d\gamma}{dt} \quad (5.57)$$

Where: G_1 – parameter characterising elastic element A,
 G_2 – parameter characterising elastic element C,
 η_1 – parameter characterising viscous element B,
 η_2 – parameter characterising viscous element D
 γ – deformation,
 t – time

Graphic interpretation of the Burgers model is presented in Fig. 5.30.

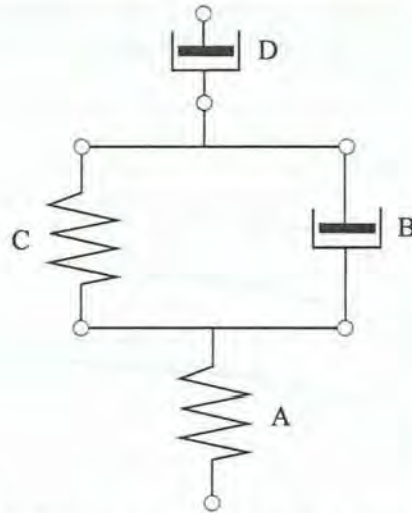

Fig. 5.30. Graphic interpretation of the Burgers model

Studies on creep can be utilized for the prediction of long-term strength properties, and one of the tools in the process can be a modification of the Žurkow equation presented in [5.29]

$$\sigma = M - N \log t \quad (5.58)$$

where: $M = \frac{U_0}{\lambda} + \frac{kT \log t_0}{\lambda \log e}$, $N = \frac{kT}{\lambda \log e}$, t_0 – constant, close to the natural period of an atom, U_0 – energy barrier corresponding to the energy of activation of the process of thermodestruction, λ – structural coefficient dependent on the features of the material and on stress distribution, $\sigma = R_{z/t}$ – temporal resistance to creep, k – Boltzman constant ($k=1,38 \cdot 10^{-26}$ kJ/K).

Experimental diagram permits the determination of the parameters U_0 , λ (utilizing two pairs of relations (σ_1, t_1) and (σ_2, t_2)),

$$\lambda = \frac{kT}{\log e} \cdot \frac{\log t_2 - \log t_1}{\sigma_1 - \sigma_2} \quad (5.59)$$

$$U_0 = \lambda \left[\frac{\log t_2 - \log t_0}{\log t_2 - \log t_1} (\sigma_1 - \sigma_2) + \sigma_2 \right] \quad (5.60)$$

Figure 5.31 presents the results of an experiment conducted on lap joint samples $b_z \times l_z = (20 \times 20)\text{mm}$, for adhesives E5/Z-1/10:1 and E5/PAC/10:8.

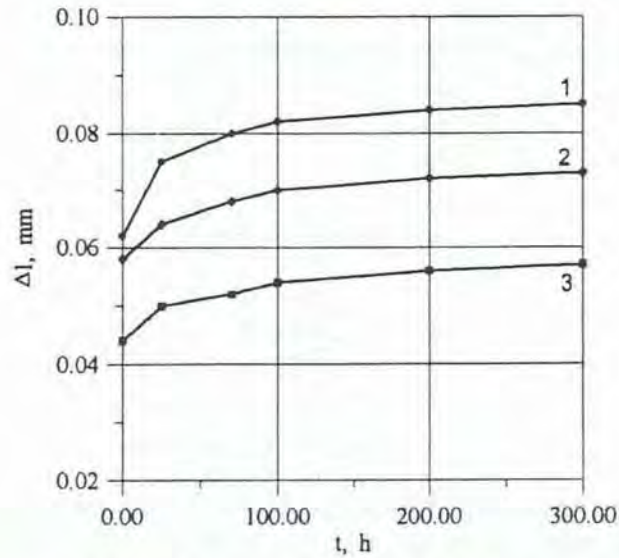

Fig. 5.31. Relation $\Delta l = f(t)$ for E5/Z-1/10:1;
 1 - $\tau/\tau_n = 0,5$, K 2 - $\tau/\tau_n = 0,3$, K 3 - $\tau/\tau_n = 0,2$ [5.22]

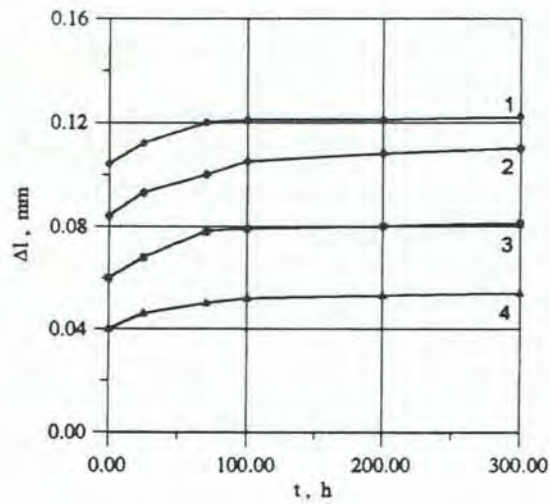

Fig. 5.32. Relation $\Delta l = f(t)$ for E5/PAC/10:8;
 1 - $\tau/\tau_n = 0,5$, K 2 - $\tau/\tau_n = 0,4$, K 3 - $\tau/\tau_n = 0,25$, K 4 - $\tau/\tau_n = 0,15$ [5.22]

The results of the studies indicate that within the range of steady creep, for loads not exceeding one half of the value of the breaking stress, the creep rate $d(\Delta l)/dt$ is approximately constant and does not depend on the value of the load. Also interesting is that within the range of steady creep the creep rate is similar for both of the adhesives applied, the one conventionally termed „stiff” (with Z-1 curing agent) and the one conventionally termed „elastic” (with PAC curing agent). The difference is significant only in the range of instantaneous strain.

The total linear deformation measured in the experiment can be written as $\Delta l_c = \Delta l_0 + \Delta l(t)$, where Δl_0 is the instantaneous strain, $\Delta l(t)$ is deformation in the function of time. Analysing the results of the study presented in figures 5.33 and 5.34 one can observe that in a logarithmic-monotonous scale they can be written in the form

$$\Delta l_c = \Delta l_0 + g_k \log t \quad (5.61)$$

If we adopt the assumption that the creep rate is approximately constant up to the critical value of the angle of non-dilatational strain, the results obtained can be extrapolated beyond the range covered in the experiment and used as a basis for the prediction of long-term strength properties. The results of the experiment in the logarithmic-monotonous scale are presented in figures 5.33 and 5.34.

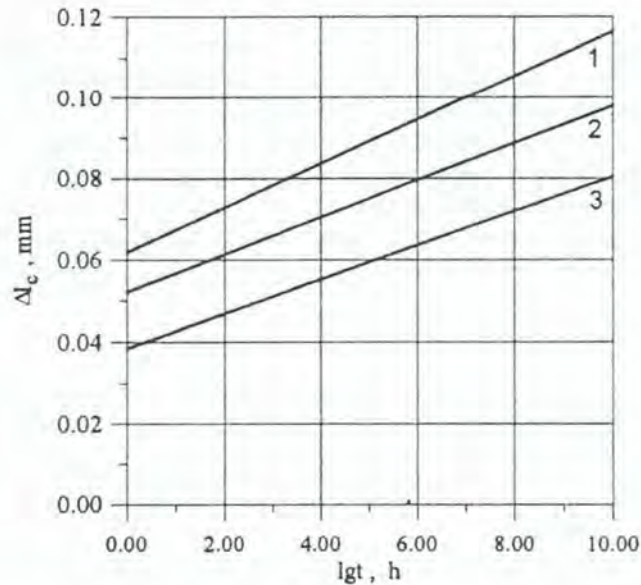

Fig. 5.33. Relation $\Delta l_c = f(\log t)$ for E5/Z-1/10:1; 1- $\tau/\tau_n=0.5$, 2 - $\tau/\tau_n=0.3$, 3 - $\tau/\tau_n=0.2$ [5.22]

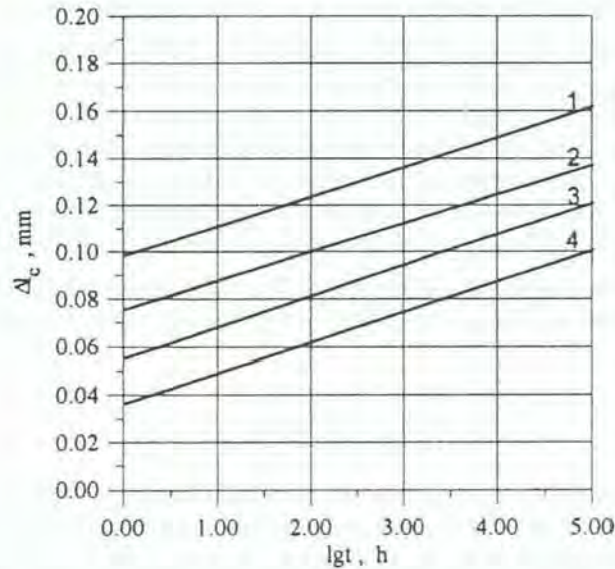

Fig. 5.34. Relation $\Delta l_c = f(\log t)$ for E5/PAC/10:8; 1 - $\tau/\tau_n = 0.5$, 2 - $\tau/\tau_n = 0.4$,
3 - $\tau/\tau_n = 0.25$, 4 - $\tau/\tau_n = 0.15$ [5.22]

In the application of thermal-temporal superposition, however, one should exercise considerable care, keeping in mind that the strength of adhesive bonds is a function of cohesive strength and adhesive strength as well. In the case of adhesive strength it is by no means obvious how adhesive forces and bonds will behave in time. This depends on a variety of factors, especially such that may cause the release of bonds, as is the case with the desorptive effect of moisture in particular. It should also be kept in mind that the processes of ageing significantly affect the properties of polymers, which may have a modifying effect on creep characteristics.

5.7. Fatigue strength of bonded joints

Fatigue strength is most frequently defined through two fundamental values [5.18, 5.35, 5.38]:

- fatigue life (service life of the joint), defined as a number of cycles that a bonded joint can transfer until the moment of its destruction at a given level of stress,
- fatigue strength (unlimited fatigue strength), i.e. the highest cyclic stress for a given cycle of stresses at which a bonded joint does not break during a number of cycles equal to the base of a fatigue test sample.

The base of a fatigue test cannot be less than 2000 cycles, the recommended value being 10^7 cycles. Standards such as ASTM D 3166-73, OCT 90112-73, DIN 54452 recommend that the mean stress in a cycle should be less than or equal to 50% of the static strength, the index of asymmetry should be 0.1, and the recommended frequency is 30Hz. The literature of the subject does not provide many reports on experiments concerned with fatigue strength, but the generalised conclusions that are formulated indicate that fatigue strength of bonded joints varies within the range of 0.15 – 0.5 of the immediate static strength. Fig. 5.35 presents an example of results of an experiment in this field.

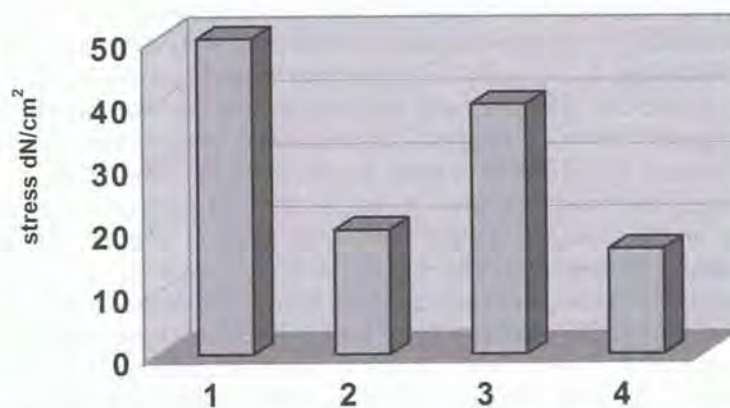

Fig. 5.35. Comparison of immediate and fatigue strength of adhesive lap joints bonded with ME1 adhesive: 1 – immediate strength for 30HGSA steel (X30CrMg-2 acc. to PN-EN 100881), 2 – fatigue strength for bonded joints of elements of that steel, 3 – immediate strength for PA7 aluminium alloy (EN-AW 20-24 acc. to PN-EN 573-3:1998), 4 – fatigue strength for bonded joints of elements of that alloy [5.24]

The ratio of fatigue strength to immediate strength depends on many factors, and especially on the viscoelastic properties of the bond, the method of adhesive curing, the rigidity of the bonded elements, etc.

Fatigue strength tests are usually conducted with sinusoidal loading. In practice we often encounter loads of stochastic character. Experiments show that for a stochastic course of loading within the scope of a given cycle the ratio of fatigue strength to immediate strength is higher than for a sinusoidal load run [5.38]. This provides an additional safety margin.

5.8. Ageing of adhesive materials

One of the most important properties of polymer materials is their resistance to environmental effects in the course of their service life. Physical and chemical

phenomena occurring under the effect of external factors lead to ageing changes in materials. The process of ageing concerns, to a lesser or greater degree, all groups of polymers, including also adhesive polymers. The growing interest in polymer materials as structural materials causes that more and more attention is devoted to the study of the process of ageing and to methods of counteracting that phenomenon. From the point of view of the user or operator, the process of ageing is an unfavourable phenomenon. It encompasses all the chemical and physical changes taking place under the conditions of operation, processing, or storage. Ageing leads considerable deterioration of the usable values of products, thus limiting the possibility of their use. Changes caused by ageing are especially important where stability of physical properties, and mechanical features in particular, is required of the material itself or of its participation in a structure.

Epoxy materials, due to their very good mechanical and adhesive properties, are extensively used as adhesives and sealants, and also as coating materials. In spite of their good mechanical properties and numerous applications, however, their usable features may be subject to changes in the course of exposure, processing, or storage. Changes occurring as a result of physicochemical processes depend, among other things, on the chemical composition of the material affected, its form, and numerous external factors [5.28, 5.32, 5.33, 5.34, 5.36, 5.45, 5.46].

In a majority of cases, the basic external factors that intensify the process of ageing of epoxy materials are heat, light, hard radiation, oxygen, moisture, active chemical compounds (acids, bases, organic solvents), mechanical effects, and microorganisms. Moreover, changes in the properties of materials largely depend on the duration of their exposure to climatic conditions and on the intensity of the constantly changing climatic effects. The most important of the groups of external factors affecting the ageing process are listed in Table 5.1.

Table 5.1. External factors intensifying the process of ageing of protective coatings and adhesive bonds [5.8, 5.12, 5.17, 5.19, 5.42, 5.45, 5.46]

Item	Group of factors	External factors intensifying the process of ageing
1	Climatic factors	Atmospheric oxygen, carbon dioxide, solar radiation, hard radiation, wind, rain, dew, fog, frost, snow, smoke, temperature gradients.
2	Operating environment factors	Mechanical factors (e.g. vibrations, variable loads, etc.), erosive factors (dust, sand), chemical factors (acids, bases, inorganic solvents, oxides of nitrogen, sulphur, carbon, hydrogen chloride, ammonia, various vapours, variable pH of the environment), thermal factors (temperature gradients), biological factors (microorganisms - fungi, bacteria).
3	Material factors	Kind of materials joined, chemical structure of material and its ability for form chemical bonds (e.g. adhesive, curing agent, paint, varnish, etc.), kind of coating material protecting the bond, etc.

4	Technological factors	Method of preparation of bonded surfaces, type of joint and method of its effecting, method and extent of its protection, etc.
5	Duration of exposure to aggressive environment	Duration of exposure to the effect of moisture, radiation, aggressive liquids and gases, temperature changes, mechanical and thermo-mechanical loads, curing time, etc.

Each of the listed factors – in a greater or lesser degree - leads to deterioration of the properties of adhesives. The action of the particular factors (and usually we encounter the combines effect of several) causes that changes occur in the material affected, most frequently of an irreversible character. The changes occur through the initiation of processes of destruction, depolymerization, degradation, crosslinking, crystallization, migration of admixtures in the polymer, and - in some cases – of increase in viscosity, formation of pseudo-crystalline phase, or micro-cracks, or through so-called polymer-analogous transformations.

The processes of ageing can be classified according to various criteria. These include, among other things, the type of environment in which the process takes place, the state of stress, climatic conditions, biological and microbiological activity, etc. Earlier, studies on ageing were conducted on the basis of visual assessment of the surface of materials, which did not permit for estimation of the kinetics of degradation not for the determination of limit states. Only in the nineteen eighties the first works in the field of IR testing appeared – spectroscopic methods. Moreover, other methods used for the assessment of ageing changes in materials include derivatographic, impedance, and strength methods [5.19].

In a general approach, it is the change in a given property of feature of a material, obtained in the course of ageing, that is adopted as the criterion for the assessment of resistance to ageing. This, according to general formulae, can be expressed as:

$$K_{\tau_1} = \frac{C_1}{C} \cdot 100\% \quad (5.62)$$

$$K_{\tau_2} = \frac{C_1 - C}{C} \cdot 100\% \quad (5.63)$$

where: K_{τ_1} , K_{τ_2} – percentage indexes of change in a property of feature resulting from ageing, C – property of feature before the process of ageing, C_1 - the same property or feature after the process of ageing.

Frequently, strength methods are used for the assessment of the kinetics of the process of ageing, consisting in the study of changes in tensile or shear strength and of changes in linear dimensions.

Due to the unfavourable effects of the process of ageing, all the research activities are focused on the development of methods for counteracting that

phenomenon. One of such methods is modification of materials, with physical and chemical methods [5.3, 5.4, 5.14, 5.29, 5.34]. Among the modification methods we can distinguish the following:

- modification of the structure of polymer through copolymerization with monomers containing groups resistant to processes of oxidation or reacting with radicals,
- blocking of end groups of the molecular chain in order to render depolymerization more difficult,
- modification of polymers with the method of admixing chemical compounds capable of intercepting free radicals.

Substances used as anti-ageing agents include the following [5.2, 5.8, 5.17]:

- thermal stabilizers, most frequently acids or salts of lead, cadmium, magnesium, calcium, sodium,
- antioxidants, most often phenols, aromatic amines, sulphates, carbon black,
- light stabilizers, most frequently derivatives of acrylonitrile, esters of aromatic acids, carbon black, 2-hydroxybenzophenol derivatives,
- combustion retardants, most often pentabromophenols, polyols containing phosphorus or halides,
- fungicides, radiational, biostabilizers, antioxidants, antiozonants, etc.

The study of the process of ageing is relatively troublesome due to the duration of experiments, complexity of phenomena taking place, and large number of factors causing or affecting the process. Methods developed for accelerated testing may yield results divergent from those obtained under actual conditions. This may be caused by increased speeds of reactions through increased temperatures, by increased intensity of action of particular factors, and by cyclic changes of conditions under which the tests take place. Therefore, it is necessary to verify the results obtained through conducting parallel tests under natural conditions.

Due to the intensive effect of phenomena occurring during ageing on the strength properties of adhesive materials, assessment of the kinetics of the process – as has been mentioned earlier - is most frequently performed on the basis of changes in tensile strength, shear strength, or in linear dimensions. Changes in the structure of materials, taking place in the process under the effect of environmental factors, cause the destruction of macromolecules and a change in the mechanical characteristics.

A thirteen-year study on adhesive bonding conducted by P. Jasiulek [5.15] shows that the atmospheric environment has a significant effect on the ageing of epoxy adhesives. Adhesive bonds aged under atmospheric and laboratory conditions display different character of changes in strength properties within the adopted time-range of testing. It turned out that the polluted atmosphere of Silesia (during the time of the study) caused a rapid decrease in the strength of adhesive bonds effected with adhesives type E57/PAC and E57/Z-1 with relation to identical joints aged under laboratory conditions. Published [5.1] results of a four-year study

by M.G.D Hockney showed that a relatively rapid decrease in the strength of an adhesive bond takes place under hot and humid climatic conditions. In the initial period of ageing, in both wet and dry environments, an increase in the strength of adhesive joints was observed. After the first year of exposure of a joint aged under the conditions of humid climate a rapid drop was recorded in its strength, and a no-change situation for adhesive bonds aged under dry climatic conditions. Research on the ageing of epoxy adhesives conducted by Z. Zaczek [5.44] provides supporting evidence for the phenomenon of reduction in the strength of an adhesive joint bonded with adhesive type *VA115+Epon* and aged under atmospheric and laboratory conditions. The study showed that the decrease in the strength of the bond is greater in the case of ageing under atmospheric conditions as compared to laboratory conditions. It also turned out that "hard" mains water causes a greater drop in the strength of adhesive joints than distilled water does. On the basis of the results obtained it was found that water environment causes a much greater decrease in strength (by approx. 40÷50%) than natural environment (ageing in the air). Moreover, ageing in oil products such as kerosene or spindle oil causes a somewhat more intensive ageing than that in the air.

The author conducted his own studies [5.21, 5.32] on the process of ageing in order to determine the character of ageing changes in adhesive lap joints. Samples were bonded with an epoxy adhesive based on *Epidian 5* epoxy resin which was hardened with triethylenetetramine (*Z-1*) and with polyaminoamide *C (PAC)*. Two adhesive sets were thus obtained - *E5/Z-1/10:1* and *E5/PAC/10:8*. As the criterion for the assessment of the kinetics of ageing-induced changes in the shear strength, the ratio of the strength after time x to the immediate strength at the beginning of the experiment was adopted. The five-year study showed that in the initial period of the experiment there occurred an increase in the strength of the bond, and then, after six months of incubation, there followed a decrease in the strength. Curves illustrating the changes in shear strength in the function of time are presented in figure 5.36.

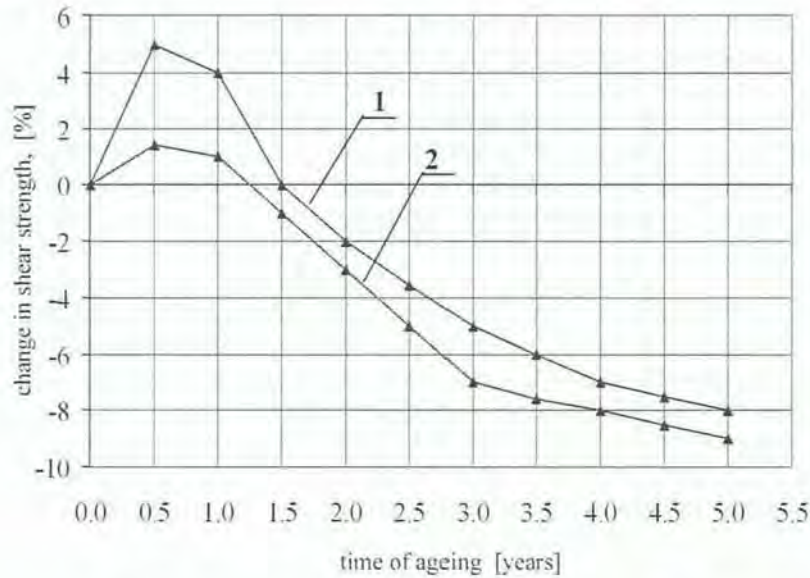

Fig. 5.36. Effect of time of ageing on the strength of adhesive bonds: 1 – E5/Z-1/10:1 adhesive, 2 – E5/PAC/10:8 adhesive [5.22]

Analysis of the obtained results of own studies, including statistical analysis, indicates that they can be approximated with the following compound function $F(x, \alpha, \beta)$:

$$F(x, \alpha, \beta) = \begin{cases} c \cdot \exp(-\beta c_1 x) & \text{for } c_1 x < 0.5 \\ \beta \alpha (c_1 x)^{(\beta-1)} \exp[-\alpha (c_1 x)^\beta] + \beta - 0.01 x c_1 & \text{for } c_1 x > 0.5 \end{cases} \quad (5.65)$$

where: $c_1 = 1$ [1/year], α, β, c - non-dimensional coefficients, x - time in years

On the basis of the results obtained the coefficients α and β of the adopted model were determined. For joints bonded with the E5/Z-1/10:1 adhesive the values of the coefficients obtained were $\alpha = 0.193$, $\beta = 0.875$, while in the case of joints bonded with E5/PAC/10:8 the values obtained were $\alpha = 0.158$, $\beta = 0.89$, respectively. The runs of values obtained through approximation within the range from 0 to 15 years are presented in Fig. 5.37, 5.38. Characteristics obtained in this manner can be used for the prediction of changes in the strength of adhesive lap joints produced with the help of E5/Z-1/10:1 and E5/PAC/10:8 adhesives.

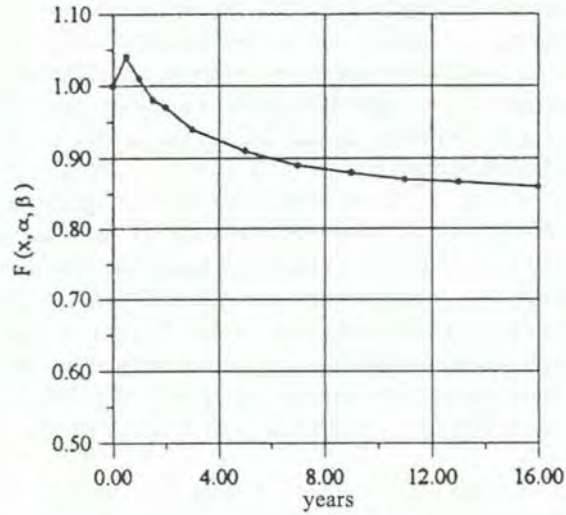

Fig. 5.37. Predicted course of changes in the strength of adhesive bonds for E5/Z-1/10:1 [5.22]

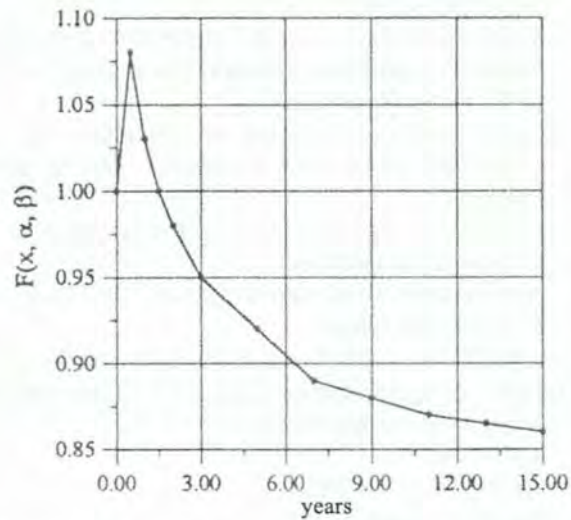

Fig. 5.38. Predicted course of changes in the strength of adhesive bonds for E5/PAC/10:8 [5.22]

The performed own studies and analysis of literature data indicate clearly that, as a result of the action of external factors of the environment and time, there occurs a change in the character of the curves illustrating the behaviour of selected

mechanical properties of epoxy materials. In a majority of cases differences in the shapes of the curves are limited only to the initial phase of the process of ageing. This phase in the process of ageing is referred to in literature as the period of incubation. Increase in strength during the incubation period (for a considerable group of cases) is attributed to an increase in the degree of crosslinking of epoxy materials, and thus to increase in the cohesive strength. It is worth noting that the analysed results of studies indicate significant effect of environmental conditions on the long-term strength of adhesive bonds, a lack of definitive correlation between the physical properties of adhesives and their long-term strength characteristics, and a good agreement of the trend function with the results of experimental studies.

The effect of the process of ageing is surface changes, changes in the structure of materials, and resultant changes in physical properties. All those changes are referred to as symptoms of the process of ageing. Symptoms of ageing of epoxy materials are most frequently analysed with relation to the factors causing that process.

The basic phenomena occurring during the ageing of polymers can be classified in several main groups [5.2, 5.8, 5.14, 5.16, 5.18, 5.41, 5.44]:

- destruction, i.e. breaking of bonds, leading to a reduction in molecular weight - caused by heat, light, radiation, oxygen, ozone, chemical agents; materials specially susceptible to destruction - PE, PP, PS, PVC, PA,
- depolymerization, i.e. decomposition consisting in emission of monomer; materials specially susceptible to depolymerization - PTFE and polycarbonates,
- degradation, i.e. process of decomposition of high-molecular compound into smaller fragments; may be caused by mechanical effects,
- migration, concerning mainly the emission of admixtures to the surface of the material,
- polymer-analogous transformation, i.e. lateral chains breaking off from the main chain,
- crosslinking, crystallization, stress corrosion, etc.

The symptoms of ageing can be categorized in two principal groups:

1. Change in external appearance:
 - loss of sheen,
 - appearance of wrinkles,
 - flaking of surface,
 - tackiness of surface,
 - tarnish, blooms on surface,
 - change in dimensions.
2. Change in properties:
 - change of strength characteristics,
 - change of longitudinal modulus of elasticity,

- change of hardness,
- change of thermal properties,
- change of optical properties.

The most important of these are grouped in Table 5.2 with relation to the external factors that cause them and to the related physicochemical processes. Table 5.2 has been compiled partially on the basis of analysis of available literature [5.2, 5.4, 5.8, 5.14, 5.16, 5.17, 5.19, 5.27, 5.29, 5.32, 5.34, 5.42, 5.45] and in part as a result of own studies.

Table 5.2. Symptoms of changes of physical properties of epoxy materials during the process of ageing [5.2, 5.3, 5.4, 5.8, 5.16, 5.17, 5.19, 5.37, 5.43, 5.46]

External factors	Kind of physicochemical process	Symptoms of ageing
UV radiation	Chemical and physical reactions (oxidation, breaking of bonds), photochemical reactions (photolysis and photo-oxidation), linear or volumetric expansion.	Increased brittleness, micro-cracks, appearance of scratches, cracks and chipping, loss of leaktightness and cohesion between coat and metal substrate, emission of coloured products of degradation, loss of sheen, loss of cohesion through different thermal expansion of epoxy material and bonded material, lowered tensile and breaking strength after period of incubation, change of characteristics of relative elongation and lowered value of Young modulus.
Moisture (water, dew, vapour, etc.)	Water absorption, swelling, water vapour condensation, corrosion of substrate, processes of biodegradation.	Change of colour, change of sheen of coat, formation of blisters, loss of cohesion, softening, swelling, lowered abrasive resistance, lower bending strength, deterioration or loss of electro-insulating properties, intensified process of corrosion of coat substrate, increased activity of sulphur dioxide and sodium chloride action on metal substrate, shorter service life, fungal growth, biological corrosion, biodegradation.
Heat	Increase in the speed of chemical reactions, appearance of thermal stresses, processes of thermodestruction, linear or volumetric expansion, increased rate of propagation of cracks, processes of softening.	Cracking due to increase rate of micro-crack propagation, crumbling and chipping of coats, loss of adhesion, cohesion, lowering of strength properties, wrinkling of coats, loss of leaktightness, accelerated processes of biodegradation and corrosion, cracking due to high temperature gradients, delamination, emission of degradation components, cracking due to shrinkage caused by lowered temperature, increase in hardness and brittleness, in the case of coats loss of adhesion to substrate.

Erosive factors (dusts, sands, smoke)	Intensification of corrosive processes, formation of sediments and retention of moisture, surface abrasion and scratching, appearance of conditions conducive to development of fungi and bacteria, sustained processes of oxidation.	Contamination of surface, formation of sediments, deterioration of parameters of stereometric features of surface – increased roughness, abrasiveness, scratches, peeling of coats, mechanical and biological corrosion, tarnish, blooms.
Microbial activity (fungi and bacteria)	Reactions of biodegradation.	Discolouration, loss of sheen, local etching, lowered hardness, adhesiveness, elasticity, flaking of surface, tarnish, blooms.

According to [5.19], UV radiation is one of the factors that most strongly destroy epoxy materials. Every chemical reaction requires activating energy. In a majority of chemical reactions the value of such energy falls within the range of 15÷65 kcal/mol, which corresponds to radiation with wavelength of $\lambda=1900\div440$ nm. Energy required to break a single covalent bond (for most cases) is 40÷100 kcal/mol (correspondingly: $\lambda=710\div290$ nm). Solar radiation reaching the earth has sufficient energy to activate photochemical degradation [5.2, 5.19] of such materials. UV radiation with wavelength $\lambda=300\div400$ nm leads to the breaking of single covalent bonds. Certain polymer structures (e.g. PP, PVC, PS) are not sensitive to the absorption of radiation with wavelength of $\lambda>300$ nm and are not subject to degradation. Processing under real conditions, however, leads to the presence of at least small amounts of contaminants (ketones, aldehydes, peroxides) or flaws in polymers. Such contaminants and flaws cause initiation of the process of absorption of electromagnetic radiation and photochemical reactions leading to the degradation of polymers. A part of that energy dissipates, but the remaining part, through photochemical reactions, causes the breaking of the main molecular chain and the formation of radicals. This, in consequence, leads to increased brittleness of the polymer, lowering of strength properties, appearance of surface cracks, loss of leaktightness of coats, and in some cases to the emission of coloured products of degradation. The formation of free radicals, which in the presence of oxygen initiate the reactions of oxidation, causes a deterioration of mechanical properties – tensile strength, breaking strength, lowered value of Young modulus, impact resistance, changes in relative elongation. The external appearance of the material also changes. The surface loses its sheen and becomes rough. The appearance of micro-cracks intensifies the process of sedimentation of hydrophilic contaminants which

are conducive to microbial growth and cause an increase in the rate of degradation of the material.

Epoxy resins are considered to be materials with low permeability, but the process of diffusion of moisture (e.g. of water vapour) is significant and has a negative effect on the properties of epoxy resin-based products. Considerable sensitivity to the effect of moisture is displayed by epoxy adhesive bonds and protective-decorative coatings. Diffusion of moisture into epoxy material consists in water molecules penetrating into the inter-macromolecule spaces and into macromolecules themselves. Although the specific structure of epoxy resin macromolecules constitutes a certain obstacle to water penetration (due to the highly developed structure and irregular shape of molecules), yet ultimately the effect of moisture leads to changes in the physical properties of epoxy materials. The length of macromolecules of epoxy materials and their spatial cross-linking, however, cause that water molecules have to cover considerable distances and cannot penetrate to greater depths. A significant role is that of the time of moisture effect and of other factors simultaneously intensifying the process of ageing. The longer the water environment affects an epoxy material the more extensive the changes caused by that factor. According to the authors quoted in reference [5.1], in the case of protective coatings alternation of wet and dry climatic conditions leads to the destruction of the coat. The coat changes its thickness, loses adhesion to the substrate, and due to the absorbed moisture, swells and softens.

Temperature, too high as well as too low, has a negative effect on the usable features of epoxy materials and epoxy adhesive bonds in particular are sensitive to heat. Increase of temperature causes a relatively rapid decrease in the strength of epoxy materials. High level of temperature may cause mechanical stress and lead to thermal degradation. The effect of increased temperature may cause the breaking of macromolecular chain at its weak links. Then a complex mixture of products appears, the origin of which can be attributed to the inter- and intra-molecular reactions of transport of radicals. Destruction proceeding according to the free radical mechanism is characteristics for most epoxy materials, especially in the presence of atmospheric oxygen. The process of thermal destruction of epoxy resins, both uncured and cured, begins at a temperature of about 200°C. A characteristic feature of thermal destruction is the emission of considerable amounts of gaseous products. In the case of protective and decorative coatings thermal effects may cause the loss of cohesiveness of the coat, and thus a deterioration in its adhesion to the substrate as well as cracking [5.8, 5.19].

Atmospheric contaminants such as dust, sand, particles of soot, ashes, volatile hydrocarbons, sulphur dioxide (rapidly oxidizing sulphur dioxide, reacting with water, forms sulphuric acid), sea salt, iron oxides and carbon oxides, cause deterioration in the usable value of epoxy materials. Some of those factors may cause loss of sheen and flaking of the surface of materials, mainly of materials used for protective and decorative coatings. Moreover, settling dust with hygroscopic properties causes retention of moisture and its diffusion into the material.

Absorption of atmospheric oxygen leads to the process of oxidation. Acid or alkaline reaction of dust in the presence of moisture may cause corrosion of epoxy coats. Increase in the humidity of the environment of operation of epoxy products may lead to microbiological corrosion or to corrosion of the metal substrate. Atmospheric contamination with sea salt particles only accelerates the process. Presence of moisture at higher temperature facilitates dissolution of salts, forming electrolyte which diffuses into the structure of the material. In particular, coats applied on metals are exposed to the effect of this type of corrosion-inducing electrolyte. Dust particles settling on the surface of epoxy materials may cause their abrasion and to deterioration of the stereometric features of the surface. Epoxy coats are characterized by low abrasive resistance. Increase in the abrasive resistance of epoxy coats can be achieved through the application of fillers. Ageing processes are considerably accelerated in large industrial centres and cities, where the level of atmospheric contamination is much higher [5.19].

Microbiological factors such as fungi and bacteria may cause discolouration, loss of sheen, local etching of epoxy materials in areas of their increased activity. Bacterial and fungal growth is augmented by the presence of carbon and nitrogen, increased temperature and humidity in the environment, and by the presence of contaminants and toxic agents discussed above. The effect of fungal activity is a decrease in the hardness of epoxy materials, and a reduction of the adhesive and elastic properties of coats. Studies showed that microbiological resistance is largely dependent on the degree of hardening of coats. Epoxy resins display a high degree of microbiological resistance as compared to other materials [5.19].

The obtained results [5.32] of studies indicate a notable relation between the time of the ageing process and the strength properties of epoxy adhesive bonds. In view of the intensive effect of phenomena occurring in the course of ageing on the strength properties of epoxy materials, and to ensure definitive interpretation of the results obtained, assessment of the kinetics of ageing can be made on the basis of strength characteristics. The ageing of epoxy coats and adhesive bonds (in a majority of cases) clearly indicates an increase of strength in the initial phase of tests, followed by a drop after the period of incubation. Intensification of phenomena taking place during the process of ageing under the effect of climatic, operation environment, and material factors is especially important in the case of epoxy adhesive bonds. Frequently adhesive bonds have an especially great contribution to the safety of structures. Ageing changes often disqualify a given material, restricting the limits of its applications. Therefore, the ability of evaluation of a given material on the basis of symptoms of ageing is an extremely important problem, a significant element of which is the choice of a suitable method for the identification of changes occurring in the material. This is relatively difficult, due to the usually high number of factors simultaneously intensifying the process of ageing under real conditions. With respect to the required physicochemical properties, ageing changes in epoxy materials can be analysed in the aspect of visually observable surface changes (e.g. changed colour, surface networks of

cracks, local etching) or changes in the mechanical characteristics (reduced strength, changes in relative elongation, changes in the values of Young modulus). Studies on the ageing process of epoxy materials, conducted by numerous researchers, indicate a distinct relation between the ageing changes and the humidity of the environment, UV radiation, and thermo-mechanical loads.

References

- 5.1. Adams R.D.: Structural Adhesive Joints in Engineering. Elsevier Applied Science Publishers. London and New York, 1984.
- 5.2. Bauer D. R. i inni: „Photodegradation and photostabilization of urethane crosslinked coatings”. *Industry Engineering and Chemical Research* 1991, N. 30, p. 2482-2487.
- 5.3. Brojer Z., Hertz Z., Penczek P.: „Żywicze epoksydowe”. WNT, Warszawa 1998.
- 5.4. Brzozowski Z. K., Pijewski M.: UV-resistans epoxy – challone resins. *Polimery* 1998, 43, nr 11-12, 720.
- 5.5. Cagle Ch.V.: Kleje i klejenie. WNT, Warszawa, 1997,
- 5.6. Chlebus E.: Podstawy kształtowania funkcjonalnych cech i własności układów konstrukcyjnych obrabiarek. *Prace Naukowe ITMiA Politechniki Wrocławskiej. Seria Monografie*, nr 14, Wrocław 1993.
- 5.7. Dietrych M. (red): Podstawy konstrukcji maszyn. Warszawa, 1995.
- 5.8. Gerlok J.L. i inni: „Photooxidation kinetics in crosslinked polymer coatings”. *Polymer Degradation and Stability* 1992, vol. 38, N. 1, p. 57-67.
- 5.9. Godzimirski J., Kozakiewicz J., Lunarski J., Zielecki W.: Konstrukcyjne połączenia klejowe elementów metalowych w budowie maszyn. *Oficyna Wydawnicza Politechniki Rzeszowskiej*. Rzeszów, 1997.
- 5.10. Goland M., Reissner E.: The stresses in cemented joints. *J. of App. Mech.* 1/1994.
- 5.11. Harsan Kasra: Wpływ czynników konstrukcyjnych i technologicznych na wytrzymałość zmęczeniową klejowych połączeń czopowo-tulejowych. *Rozprawa doktorska*, Politechnika Rzeszowska, 1997.
- 5.12. Hyla I.: Tworzywa sztuczne. Własności – przetwórstwo - zastosowanie. *Wydawnictwo Politechniki Śląskiej*. Gliwice, 2004.
- 5.13. Hyla I., Ślężiona J.: Kompozyty. *Elementy mechaniki i projektowania*. *Wydawnictwo Politechniki Śląskiej*. Gliwice, 2004.
- 5.14. Jachowicz T.: Badania wpływu procesów starzeniowych na wybrane właściwości telekomunikacyjnych rur osłonowych z polietylenu. *Rozprawa doktorska*. *Politechnika Lubelska*, 2002.
- 5.15. Jasiulek P.: „Wyniki trzynastoletnich badań starzenia stalowych połączeń klejowych”. *Materiały konferencyjne*, Kozubnik 1988.
- 5.16. Józwik J., Kuczmaszewski J.: „Wytrzymałość długotrwała statyczna połączeń klejowych”. *Materiały Polimerowe i Ich Przetwórstwo*. *Wydawnictwo Politechniki Częstochowskiej*, Częstochowa 2000.
- 5.17. Józwik J., Kuczmaszewski J.: Starzenie tworzyw epoksydowych. *Przetwórstwo tworzyw* 3-4/2001.
- 5.18. Kocańda S., Szala J.: Podstawy obliczeń zmęczeniowych. *Wyd. Naukowe PWN*, Warszawa 1985.
- 5.19. Kotnarowska D.: „Wpływ procesu starzenia na trwałość powłoki epoksydowej”. *Wydawnictwo Wyższej Szkoły Inżynierskiej*, Radom, 1994.

- 5.20. Krzemiński J.: Podstawy mechaniki pękania i tworzenia mikroszczelin. Politechnika Poznańska, 1975.
- 5.21. Kuczmaszewski J.: Prognozowanie wytrzymałości statycznej wybranych połączeń adhezyjnych. *Polimery* 7-8/1988.
- 5.22. Kuczmaszewski J.: „Podstawy konstrukcyjne i technologiczne oceny wytrzymałości adhezyjnych połączeń metali”. Wydawnictwo Uczelniane, Lublin, 1995.
- 5.23. Kuczmaszewski J.: Obliczanie zakładkowych połączeń klejowych. *Przegląd Mechaniczny* 2/1988.
- 5.24. Lurski M.: Wytrzymałość na obciążenia wahadłowe przy ścinaniu zakładkowego połączenia klejonego metali. Materiały Kraj. Konf. Techn. „Problemy wytrzymałości konstrukcji klejonych. PTMTiS, Szczecin, 1972.
- 5.25. Łączkowski R.: Katastroficzny model nieliniowej mechaniki pękania. *Przegląd Mechaniczny* 12/1989.
- 5.26. Neimitz A.: Mechanika pękania. Wydawnictwo Naukowe PWN, 1998.
- 5.27. Nicholson J.W.: „Chemia polimerów”. WNT, Warszawa, 1996.
- 5.28. PN 88/H-04336. Metoda badania odporności na pęknięcie przez wyznaczanie krytycznej wartości całki J, J_{IC} .
- 5.29. Nowak M.: Wytrzymałość tworzyw sztucznych. Wydawnictwo Politechniki Wrocławskiej, Wrocław, 1987.
- 5.30. Porębska M., Skorupa A.: „Połączenia spójnościowe”. PWN, Warszawa, 1993.
- 5.31. Schimmer M.: Festigkeitsrechnung für Klebverbindungen. *Kunststoffe* 76/1986.
- 5.32. Sikora R., Kuczmaszewski J.: Badania wytrzymałości długotrwałej statycznej niektórych konstrukcyjnych połączeń adhezyjnych. *Polimery* 1986, 31, nr 9.
- 5.33. Sikora R.: „Tworzywa wielkocząsteczkowe. Rodzaje, właściwości i struktura”. Wydawnictwo Uczelniane, Lublin 1991.
- 5.34. Sikorski R.T.: „Podstawy chemii i technologii polimerów”. WNT, Warszawa 1981.
- 5.35. Szala J.: Ocena trwałości zmęczeniowej elementów maszyn w warunkach obciążeń losowych i programowych. Akademia Techniczno-Rolnicza w Bydgoszczy. Bydgoszcz 1980.
- 5.36. Szlezyngier W.: „Tworzywa sztuczne. Chemia. Technologia wytwarzania. Właściwości. Przetwórstwo. Zastosowanie”. Tom II, Wydawnictwo Oświatowe FOSZE, Rzeszów 1998.
- 5.37. Szlezyngier W.: Właściwości wytrzymałościowe modyfikowanych, klejowych żywic epoksydowych. *Technologia i automatyzacja montażu*, nr 3/1994.
- 5.38. Topoliński T.: Analiza teoretyczna i badania kumulacji uszkodzeń zmęczeniowych konstrukcyjnych kompozytów polimerowych. Politechnika Gdańska 1998.
- 5.39. Weroński A., Hejwowski T.: *Thermal fatigue of metals*. Marcel Dekker, Inc. New York, 1991.
- 5.40. Wilczyński A.P.: *Mechanika polimerów w praktyce konstrukcyjnej*, WNT, Warszawa, 1984.
- 5.41. Wilczyński K.: *Reologia w przetwórstwie tworzyw polimerowych*. WNT, Warszawa 2001.
- 5.42. Winkler J., Zajac W., Bursa J.: „Starzenie kompozytów epoksydowych w atmosferze ozonu”. Materiały konferencyjne, Kozubnik 1988, 239.
- 5.43. Wnuk M.P.: *Podstawy mechaniki pękania*. AGH, Kraków, 1981.
- 5.44. Zaczek Z.: „Studium wytrzymałości statycznej i odporności na działanie środowiska klejonych połączeń metali i laminatów szklanych”. Wydawnictwo Wyższej Szkoły Marynarki Wojennej, Gdynia 1973.

-
- 5.45. Zahavi J.: „Solid particles erosion of polymeric coating”. *Wear*, 1981, vol. 71, N.2.
5.46. Żuchowska D.: „Polimery konstrukcyjne”. WNT, Warszawa 1995.

Chapter 6

Special tooling for bonding operations

6.1. Typical procedures in bonding operations

Technological tooling is used in all the phases of the process of adhesive bonding, from the preparation of the adhesive composition to the inspection of effected joints. Major functions of technological tooling in adhesive bonding operations are the following:

- dosage and mixing of components of the adhesive,
- application of adhesive on the surface,
- application of suitable clamping pressure on bonded surfaces,
- maintaining correct temperature of bonding process,
- fixing of bonded elements,
- to facilitate or permit the processes of inspection,
- sealing of the bonding area,
- fulfilment of auxiliary functions in operations of inspection of joints,
- other functions resulting from the specific character of the operation.

6.2. Dosage and mixing equipment

Preparation of adhesives depends on their form, type, and manner of curing, the most important factor being the form or consistence. Adhesives can be solid (lumps, sticks, films, powders), semi-liquid (pastes) and liquid. In the case of multi-component adhesives, especially those chemically cured, the dosage of components and their mixing together is very important.

The term mixing equipment (mixers) covers devices in which various substances are mixed together in a forced manner, irrespective of the physicochemical processes that take place inside.

Dosage equipment means devices that, in a forced and repeatable manner, meter out predetermined amounts of substances. Dosage of components can be effected by means of droppers, special metering tips or nozzles, and other devices.

A variety of mixers are used, depending on the form of substances mixed and on the purpose of the mixing operation. Effectiveness of mixing largely depends on the type of mixer. More important types of mixers are presented in Fig.6.1.

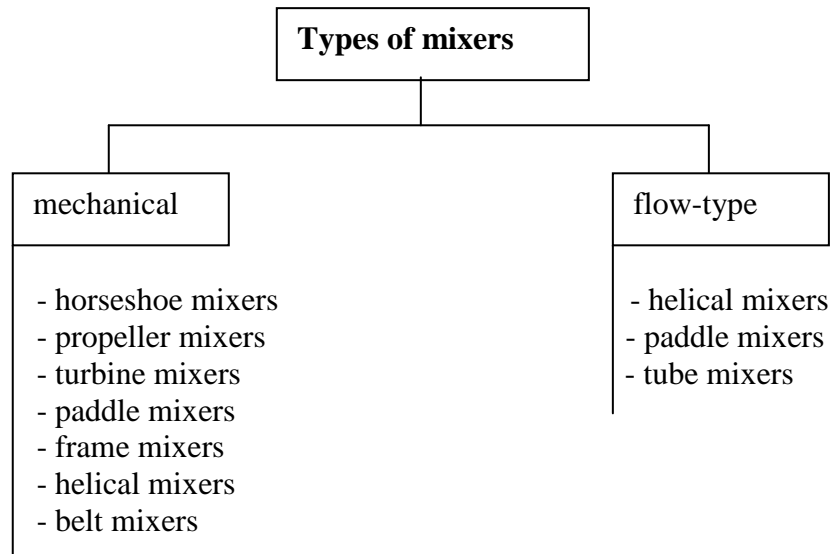

Fig. 6.1. Major types of mixers [6.3, 6.6]

The choice of mixer is strongly related with the rheological properties of the adhesive, and especially with its viscosity. Fig.6.2. presents relevant recommendations.

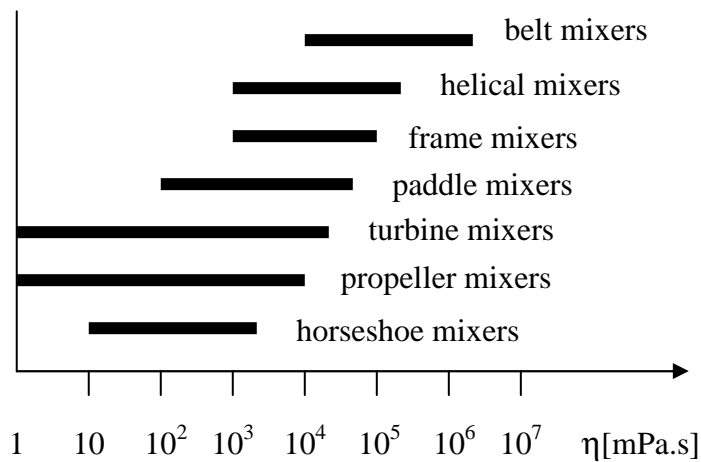

Fig. 6.2. Recommended types of mixers with relation to viscosity of mixture of liquids [6.6]

High-melt adhesives are applied in liquid state, using special pouring heads, pistol-type applicators with heating elements, or special sets composed of a pot for

melting the adhesive, a pump, and an applicator. In the case of large surfaces, adhesive can be applied by means of special electrically- or steam-heated rollers.

Adhesives in the form of paste are applied by means of putty knives or spray-guns.

Adhesives in the form of powders can be sprayed by means of mechanical, electrostatic or electromechanical spray-guns; curtain-type spreaders can also be used.

The following should be taken into consideration when designing mixing equipment:

- the substance mixed is an adhesive material and easily adsorbs on elements of the mixer, hence the recommendation to use such materials for stirrers and mixing chambers that have the lowest possible value of surface energy,
- mixers should be easy to disassemble and the mixing chamber readily accessible, to facilitate the process of cleaning after use, provided the equipment is not disposable,
- the process of mixing of the components of an adhesive should protect the substance against aeration - gas molecules introduced into the adhesive composition may cause decohesion of cured adhesive.

Dosage or metering equipment plays a very important role, especially in the case of chemically cured adhesives. The curing agent should be added to the resin (resin is often mixed with modifying admixtures) in amounts close to stoichiometric. Available on the market are simple and disposable metering devices, plunger- or flow-type. Those are used primarily by individual users who buy adhesives confectioned in special containers. On the outlet nozzle of such a metering container one has to place a static flow-type mixer attachment which splits the outflow in an exponential manner:

$$n=2^k \quad (6.1)$$

where: k - number of cascades.

Every cascade divides a single outflow jet in two. As a rule, such a mixer attachment has about 10 cascades, and sometimes even more, so the result is good mixing of the base (resin and modifying admixtures) with the curing agent.

6.3. Adhesive applicators

Application of adhesives can be manual or mechanized in character. More important types of applicators or spreading equipment are classified as shown in Fig. 6.3.

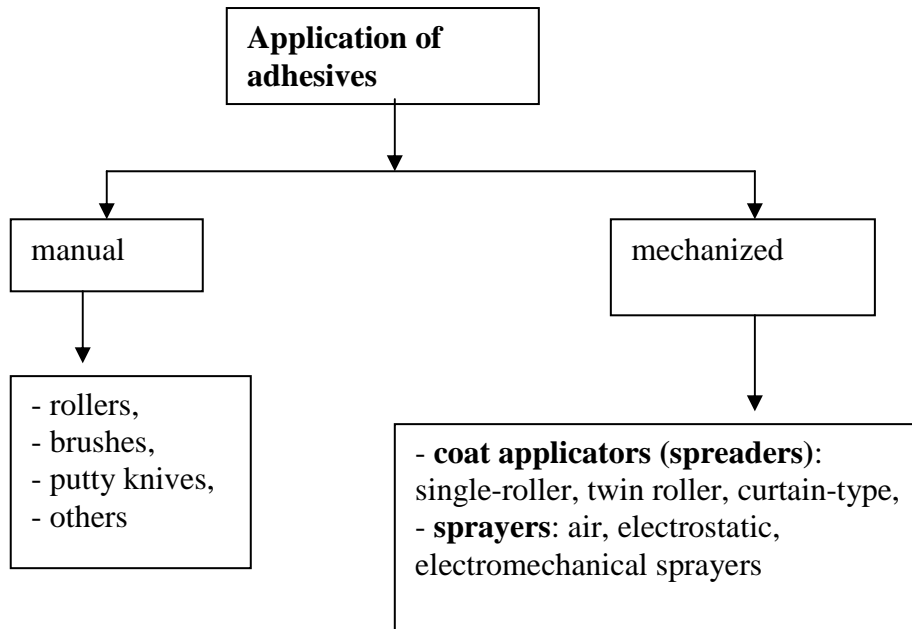

Fig. 6.3 Typical equipment for the application of adhesives

When bonding small elements under conditions of piece production or small batch production the adhesive can be applied by hand, using a brush or a putty knife. In a situation when the adhesive is applied onto large surfaces, specialized equipment for adhesive application is required (Fig. 6.4, 6.5). These can be mechanical spreaders using the forces of gravity, friction or inertia in the process of adhesive application, or coating equipment, such as e.g. equipment for electrostatic application of adhesives.

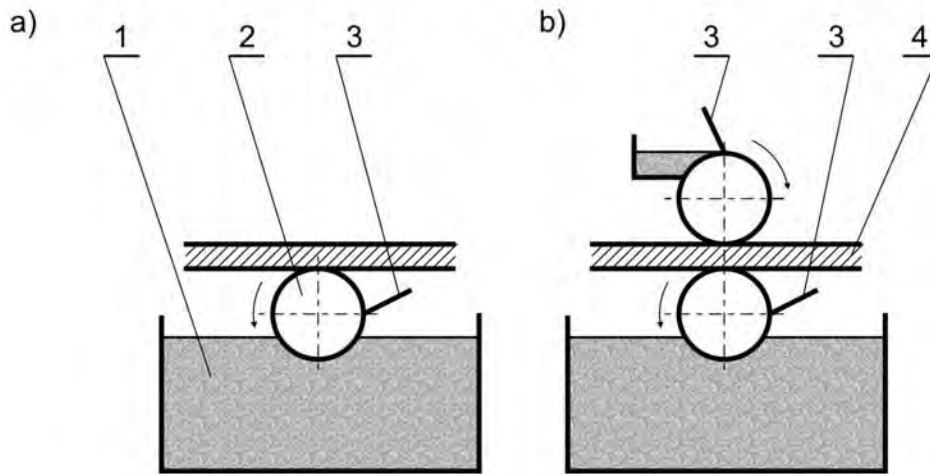

Fig. 6.4. Principle of operation: a – of single-roller spreader, b – twin-roller spreader: 1 – container with adhesive, 2 – roller, 3 scraper edge, 4 – material coated with adhesive [6.3]

More economical in operation and at the same providing a more uniform coat of adhesive are curtain-type spreaders, a schematic of operation of which is presented in Fig. 6.5.

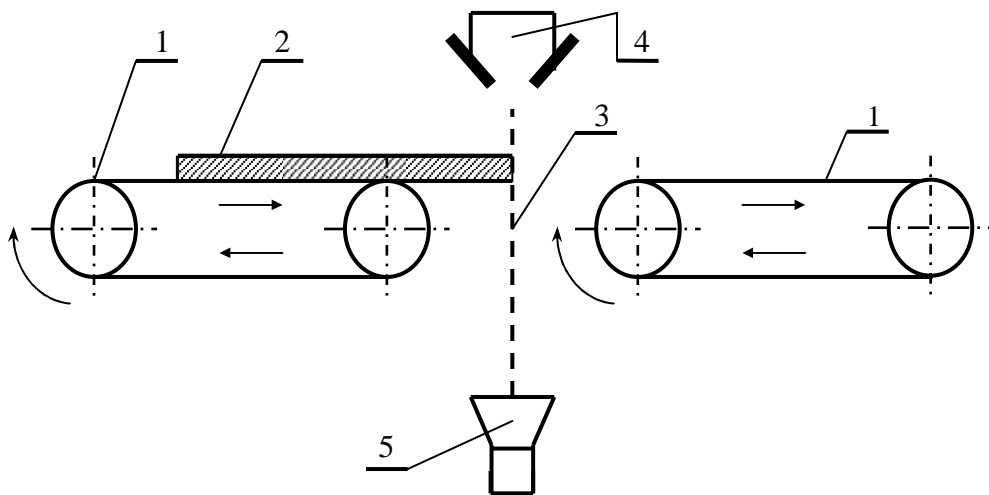

Fig. 6.5. Schematic of a curtain-type adhesive spreader: 1 – belt conveyor, 2 – element bonded, 3 – adhesive, 4 – head, 5 – drip trough [6.3]

A curtain-type adhesive spreader is equipped with a head, from which the adhesive flows through a controlled-width slot, and a conveyor moving the coated elements at controlled speed.

The best uniformity of adhesive coat application on a surface can be achieved through spraying. The method can be used to apply adhesives in liquid and powdered form, using air, mechanical, electrostatic and other types of sprayers. Air spray-guns are relatively simple in design, but burdened with the following shortcomings:

- considerable loss of adhesive in the form of atomized mist,
- high energy consumption of the process,
- contamination of the working environment,
- high consumption of solvents, etc.

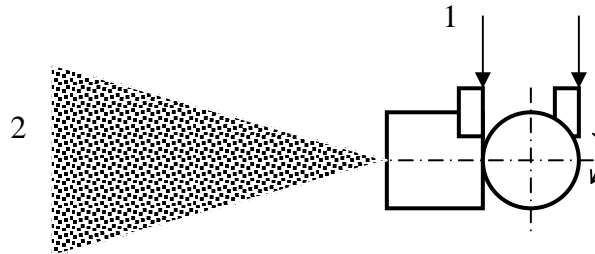

Fig. 6.6. Schematic of operation of a mechanical sprayer for adhesives; 1 – inlet, 2 – sprayed adhesive

Stream of adhesive gets into the sprayer through an inlet located on a tangent to the surface of the canal, slides on its cylindrical surface under the effect of centripetal force. At the same time, under the effect of pressure, the adhesive moves axially towards the outlet. It is estimated that, in comparison with air spraying, the consumption of adhesive is reduced by approximately 20%. Figure 6.7. presents an example of a device for the application of adhesive in electrostatic field.

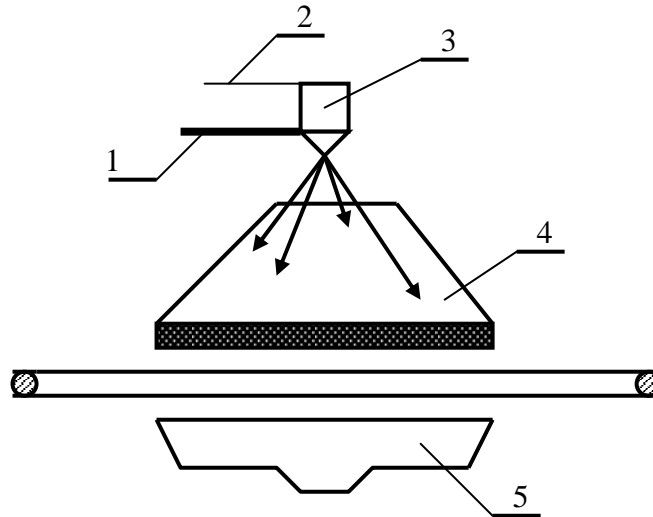

Fig. 6.7. Schematic of device for adhesive application with electrostatic method: 1 – high voltage lead, 2 – adhesive supply by means of compressed air, 3 – reciprocating spraying nozzle, 4 – metal element coated with powdered adhesive, 5 – dust collector removing excess adhesive

The equipment shown in figures 6.4 – 6.7 is used in large lot production and for the application of adhesives onto large surfaces. It permits a reduction in the time of adhesive application and in its consumption, and ensures uniform thickness of the coat of adhesive applied.

6.4. Fixtures and alignment tools

Alignment of bonded surfaces in the process of adhesive bonding is difficult. This results both from the presence of liquid adhesive between the bonded elements, which causes that the elements move easily with relation to each other, and from the frequently large dimensions of the bonded elements, these – as a rule – being thin-walled structures. Correct alignment of bonded elements should ensure not only correct mutual positioning of the elements, but also uniform thickness of the bond. Fixing of mutual alignment of flat elements can be achieved with conventional clamping and thrust elements. When bonding metal sheets, uniform thickness of the bond is usually a secondary issue; under the effect of properly chosen pressure element and force there occurs a process of self-alignment of the elements, with the bond thickness being related to the viscosity of the adhesive. In certain situations it is possible to use spacing elements, such as e.g. lengths of wire of specific diameter.

The problem of alignment is more significant in adhesive-mounting of rolling bearings, gears and pulleys, and other elements mounted on shaft trunnions or journals in the form of trunnion-sleeve joints. Such situations require good coaxiality of the elements joined. More and more frequently, trunnion-sleeve adhesive bonds replace conventional key joints. This results from economic reasons – in the case of bonding technology there is no need for high accuracy machining of the hole and trunnion (it is sufficient to apply a fitting gap of about 0.1 mm), moreover, adhesive bonds has good shock absorbing properties, which is also highly desirable. Gears, pulleys and other elements often have considerable mass, so they can get displaced relative to each other during rotary motion in spite of the phenomenon of self-alignment. In this situation the joint may have notable flaws, especially face or radial run-out. Therefore, bonding in such situations should be effected in special fixtures. An example of the design of such a fixture is schematically presented in Fig. 6.8.

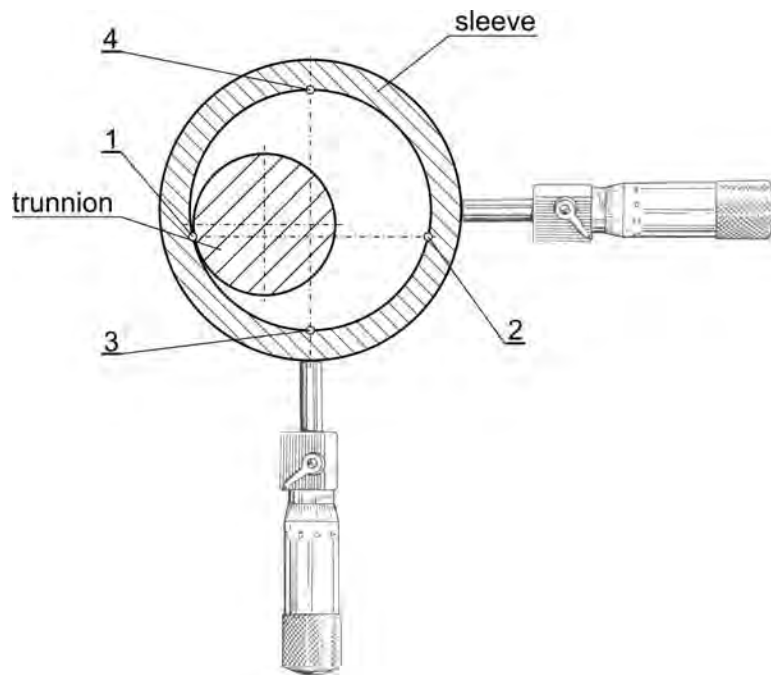

Fig. 6.8. Principle of operation of fixture for trunnion-sleeve concentricity alignment

Let us assume that the element that is moved, e.g. by means of a micrometric screw in a special fixture, is a trunnion which, initially, is random located with relation to a sleeve. By rotating the screw for lateral adjustment we bring the trunnion and sleeve into contact at point 1. The fact of contact may be signalled by the illumination of a control light. Taking a readout of the position, we then turn the

screw until achieving contact with the sleeve at point 2. Knowing the length of section 1-2 we can retract the trunnion by a half of that section, obtaining correct positioning of the trunnion relative to the vertical axis. The same procedure is followed in the other plane, moving the trunnion to point 3 and then to point 4, and retracting the trunnion by one half of section 3-4. In this way we obtain concentricity of the trunnion and the sleeve. For better clarity of the drawing, the difference in the diameters is greatly exaggerated. In reality the difference is approximately 0.3 mm, hence the necessity of using accurate instruments for correct alignment of the trunnion and sleeve.

6.5. Equipment for application of clamping pressure

Technological discipline of adhesive bonding process, and especially observance of technological parameters concerning pressure and temperature, is one of fundamental conditions of achieving high indexes of bonding quality [6.2, 6.7]. In adhesive bonding operations appropriate clamping pressure is achieved in the following major ways:

- clamping pressure applied in spring or pneumatic equipment,
- negative pressure clamping,
- pressure applied in by means of hydraulic, screw and pneumatic presses,
- pressure applied by means of mechanical clamps,
- pressure applied by means of magnetic equipment,
- pressure applied by means of hybrid equipment.

It is frequent to combine the functions of applying clamping pressure and maintaining correct process temperature in a single device. These are, most often:

- autoclaves,
- chamber driers with mechanical or pneumatic systems,
- fixtures and devices with spot heating system,
- clamping tables with electric or steam heating,
- presses with heating plates,
- radiation lamps,
- ultrasonic generators,
- special devices with liquid heating medium.

In the case of high-responsibility structures, e.g. aircraft, adhesive bonding operations are frequently performed in complex and expensive devices such as autoclaves. Fig. 6.9 presents schematically the major functional groups or systems of an autoclave.

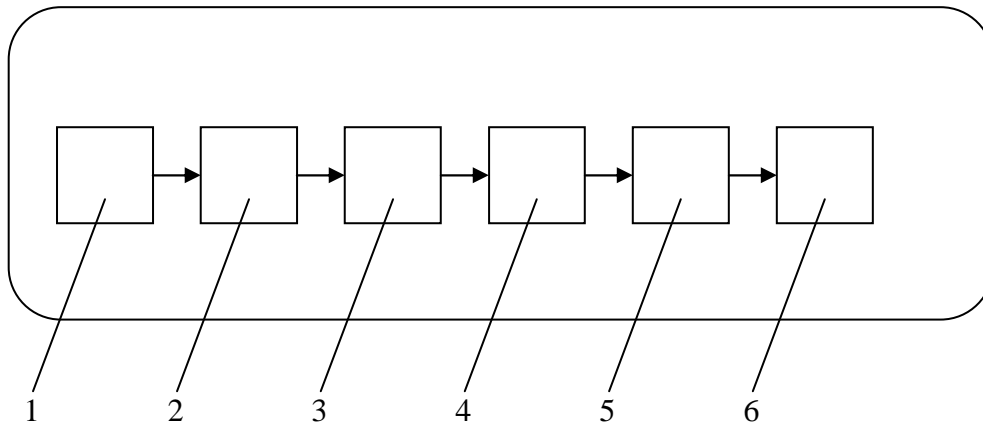

Fig. 6.9. Functional elements of autoclave: 1 – pressure system, 2 – negative pressure system, 3 – heating system, 4 – cooling system, 5 – control and monitoring system, 6 – loading-unloading system

Autoclaves are usually large enough to hold elements of considerable dimensions, like for example helicopter rotor blades. Bonded elements are placed in special bags from which air is then “sucked out”. In this way pressure is applied uniformly over the whole surface area. The curing cycle is controlled automatically. The idea of the pressure-vacuum method is presented in Fig. 6.13.

Adhesive bonding is frequently performed on compound surfaces, where uniformity of pressure over the whole bonding area is important. This can be achieved through the application of alignment and clamping equipment corresponding to a “negative” of the bonded surface, or by using diaphragm pressure devices. Flexible diaphragms, coupled with a suitable pressure or vacuum system, permit such effective clamping pressure. Modern systems tend to employ negative pressure solutions. Moreover, the “sucking out” of air mentioned before permits additionally the removal of air from the cohesive zone of the adhesive or from the phase boundary area. Figures 6.10 – 6.12 present schematically several designs of pressure devices used in bonding equipment.

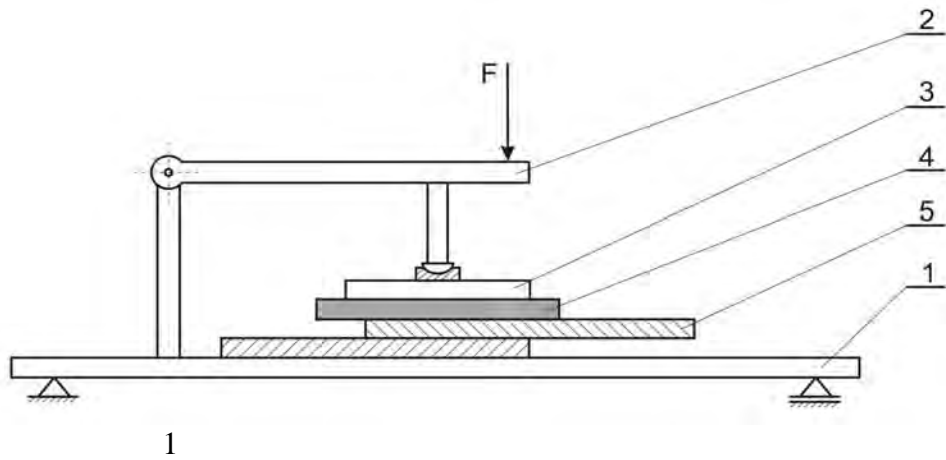

Fig. 6.10. Lever-type bonding fixture with mechanical clamping: 1 – base, 2 – clamping arm, 3 – swivel pressure plate, 4 – elastic pad, 5 – element of lap joint

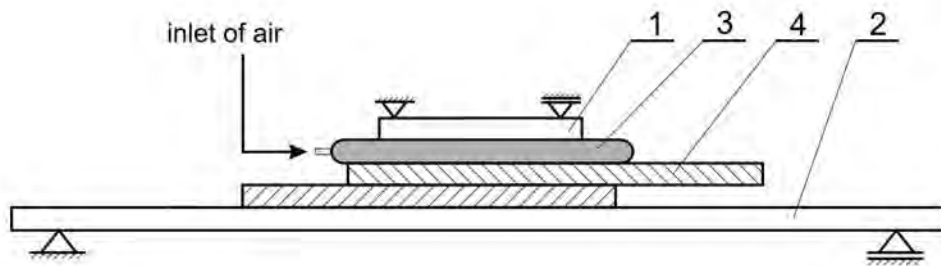

Fig. 6.11. Bonding fixture with pneumatic clamping system: 1 – upper plate, 2 – lower plate, 3 – air pressure bag, 4 – lap joint

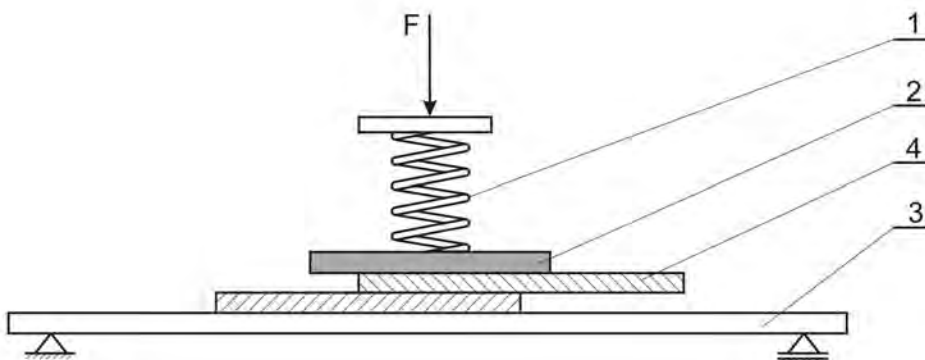

Fig. 6.12. Bonding fixture with spring-type clamping system: 1 – pressure spring, 2 – plate clamp, 3 – base, 4 – bonded lap joint

Usually in bonding fixtures the element considered as the mechanical clamp is a rigid element accurately reproducing the profile of the bonded elements. That element is usually lined with an elastic material, for instance with rubber. The lining permits uniform pressure to be applied over the whole surface area and eliminates local concentration of pressure resulting from machining errors of clamping elements and of particular elements of the bonded component. As a rule it is inadmissible to use point pressure clamping, except when bonding very rigid elements. Highly important in adhesive bonding operations are diaphragm-type clamping devices, used in autoclaves and in pressure-vacuum systems. The idea of the pressure-vacuum method is presented schematically in Fig. 6.13.

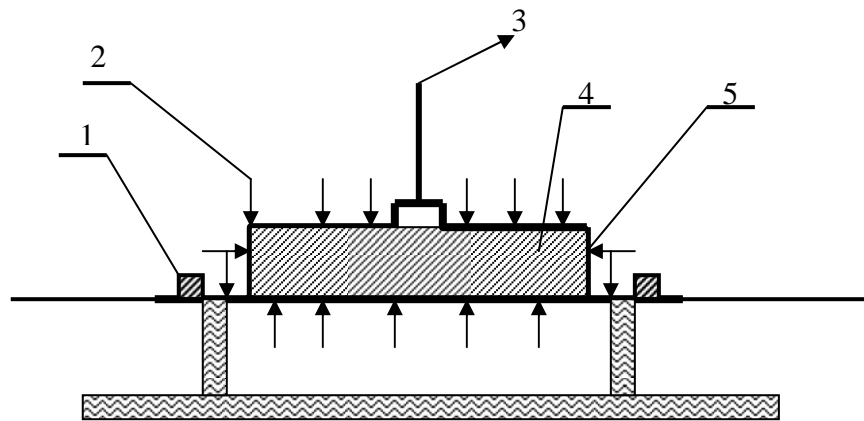

Fig. 6.13. Principle of operation of pressure-vacuum systems: 1 – spring clamp, 2 – atmospheric pressure, 3 – vacuum pump connection, 4 – bonded elements, 5 – negative-pressure bag

Placing the bonded elements in the negative-pressure bag (from which air is removed by the vacuum pump) ensures uniformity of pressure applied to the bonded surfaces.

6.6. Heating equipment

The following methods of heating are most frequently used in adhesive bonding operations:

- electric (resistance) heating in heating chambers,
- induction heating,
- ultrasonic heating,
- heating with infrared lamps,
- heating with a circulating heating medium.

Temperatures at which the process of curing is conducted usually do not exceed 180°C. For high-melt adhesives (usually derivatives of thermoplastics) curing temperatures are lower; the reason for applying elevated temperature in such cases is melting the adhesive down and obtaining the lowest viscosity possible. In the case of chemo-setting adhesives the objective is increase in the degree of crosslinking of cured adhesive and improvement in its operation properties, especially increase in its resistance to loads under conditions of elevated temperature. Curing at elevated temperatures must proceed at correct rates of heating and cooling. It is necessary to be aware of the various thermal characteristics of the adhesive and the materials bonded. One should also keep in mind that elevated temperature may initiate various chemical processes in the cohesive zone of the adhesive and at phase boundary, as well as cause considerable thermal stress.

6.7. Important tips for engineers designing bonding fixtures

Bonding fixtures equipment are designed for specific technological situations [6.3, 6.4], nevertheless some issues of universal character should be taken into considerations, such as:

- pressure should be applied uniformly on the whole surface of bonding, and for this reason point pressure clamping is not used in bonding fixtures,
- bonding fixture should be designed so as not to cause deformation of bonded elements,
- bonding fixture should permit free thermal expansion of bonded elements,
- heating elements should be designed so as to ensure uniform temperature distribution over the whole bonding area,
- bonding fixture should permit control of clamping pressure value,
- aligning and fixing elements should basically have the form of a negative of the bonded elements,
- heating elements should be designed so that the area of adhesive bond is uniformly heated throughout. Also important is automatic temperature control with effective protection against exceeding a preset limit value,
- in many cases the fixture should ensure sealing of the bond zone.

More and more frequently bonding fixtures are equipped with control and monitoring systems that ensure fully automatic operation. This concerns not only large-lot production, but also small batch production or even piece production. In aircraft or space industry the objective is total elimination of the human element from the process. Effects of adhesive bonding largely depend on the observance of strict technological discipline, and contact of bonding surface - after the completion of the process of its preparation for the bonding operation – with tools or human hand is totally inadmissible.

References

- 6.1. Feld M.: Technologia budowy maszyn. PWN, Warszawa, 1995.
- 6.2. Feld M.: Uchwyty obróbkowe. WNT, Warszawa, 2002.
- 6.3. Kuczmaszewski J.: Technologia śmigłowców. Teoria i technika klejenia. Wydawnictwa Uczelniane Politechniki Lubelskiej. Lublin, 1990.
- 6.4. Kuczmaszewski J., Rudawska A.: Klejenie blach ocynkowanych. Wydawnictwa Uczelniane Politechniki Lubelskiej. Lublin, 2005.
- 6.5. Kuczmaszewski J., Borowski G.: Utylizacja drobnoziarnistych odpadów metalowych. Wydawnictwa Uczelniane Politechniki Lubelskiej. Lublin, 2005.
- 6.6. Lewicki P.P. (red.): Inżynieria procesowa i aparatura przemysłu spożywczego. WNT, Warszawa, 1990.
- 6.7. Sikora R.: Oprzyrządowanie technologiczne. Przegląd Mechaniczny 1/1983.

Chapter 7

Design of bonded joint structures

7.1. Input data for bonded joint design

The strength of adhesive bonds should be analysed both in the context of adhesive and of cohesive strength, the strength of the joint as a whole being determined by the strength of the weakest link or element. Analysing cohesive strength one should take into account the fact of active influence of surface, or rather of the surface layer of metal, on the structure and strength of the bond. Attempts of simple transformation of results of cohesive strength tests of samples cast from the adhesive onto the same material in an adhesive bond is burdened with an unacceptable risk of error, and cannot be applied for all groups of adhesives. Moreover, it is necessary to take into consideration the effect of structural non-homogeneity on cohesive strength is we accept the postulate of unavoidability of occurrence of such non-homogeneities in the structure of adhesives. No less difficult to predict is the adhesive strength, the difficulty basically resulting from the very essence of adhesion as a complex of phenomena that are still little known till now. In design work on adhesive bonds it is necessary to take into account the effect a various technological, structural and operational factors on their strength.

The major technological and structural factors include [7.5]:

- kinds of adhesive applied and of materials bonded,
- method and care applied in the preparation of surfaces for bonding,
- technological parameters of bonding (temperature, surface pressure),
- time elapsing from the moment of preparation of adhesive to its application on bonded surfaces,
- thickness of adhesive bond,
- manner of loading applied to the bond,
- shape and dimensions of the bond,
- technological discipline during the bonding process, and especially during the metering out and mixing of components.

Choice of the type of adhesive used is one of the first steps in the process of designing a bond. There is no single adhesive that would ensure good bonding effects with respect to all materials. There are many adhesives for metal bonding available on the market, differing significantly in their chemical structure and physicochemical properties. The choice of proper adhesive requires consideration of numerous factors, and primarily:

- environmental conditions under which the bond will be operated,
- rigidity of bonded elements,
- coefficients of thermal expansion of cured adhesive and bonded materials,

- load value and manner of loading of bond and duration of projected operation,
- kind of materials bonded,
- location of the bonds in the structure.

The choice of suitable adhesive is a key problem and the ultimate determining factor for the success of long-lasting and reliable operation of the bond, but it is not a sufficient condition. Another important factor is the adopted method of surface preparation. The ability to predict the effects of mechanical and chemical preparation of surfaces with respect to the application of specific materials is a very important element in the design of bonding process, and especially in the determination of conditions of technological discipline.

The geometric features of the bond are an extremely important factor. More information on that is given in [7.4].

A problem of bonding technology that is usually underestimated is the time that elapses from the moment of adhesive application on bonded surfaces to the moment of actual joining together of the bonded elements. This is especially important for chemical setting adhesives.

The factors enumerated are important, but they do not exhaust the problem. It is also necessary to take into consideration the manner of loading, operating conditions, method of protection of the bond against environmental effects, diurnal cycle of temperature and humidity, and other that the design and process engineers will assume to be important.

Designing adhesive joints requires analysis of the following major types of input data:

- scale of production,
- kind of materials bonded,
- dimensions of elements joined,
- functions and importance of the joint in the structure,
- features of the environment in which the joint is to be operated,
- character of load that will be applied to the joint,
- rigidity of the structure,
- importance, level of responsibility of the joint in the structure,
- other types of data as required.

The scale of production determines primarily the degree of automation of the bonding operations, the type and number of technological equipment, logistic solutions, and the required size of the bonding workstation.

The type of bonded materials determines the kind of auxiliary operations, such as the method of surface preparation, choice of adhesive, technological parameters of adhesive curing.

The dimensions of joined elements have a fundamental effect on the method of adhesive application, choice tooling for mutual alignment of the joined elements, and have a bearing on the choice of adhesive.

Correct process engineering of the operation of adhesive bonding requires knowledge of the functions and importance of the joint in the structure. Requirements relating to adhesive joints may be various and include, among other things, high strength, good sealing properties, suitable plastic properties, resistance to elevated temperature, resistance to the destructive effect of the environment, physiological inertness, suitable electric, magnetic characteristics, etc.

Knowledge of the features of the environment in which the joint will be operated is important for the choice of a suitable adhesive, hardening parameters, method of surface preparation, and also appropriate protection of the bond, e.g. through the application of suitable paint coats on the bond.

The load character determines the shape of the bond, the size of the bonding surface area, and in the case of lap joints also the application (or not) of overlap end chamfering. Operation at elevated temperatures or under conditions of high humidity has a significant effect on the choice of adhesive and auxiliary materials.

Rigidity of the structure has a significant effect on the choice of clamping pressure application method. Elements with low rigidity require uniform pressure over the whole bonding area.

The importance and degree of responsibility of the joint in the structure determine primarily the value of the factor of safety of the strength of the structure.

7.2. Analysis of stress status

Prediction of the strength of adhesive bonds is difficult, and the result is always burdened with a degree of uncertainty. Such bonds are employed in highly responsible structures, and their “over-engineering” resulting from the adoption of too high a factor of safety is not always permissible due to the necessity of miniaturization of certain structures.

Analysing the stress status of a joint special attention should be paid to the following elements:

- load variability, i.e. whether the joint will operate under typical work conditions or dynamic loads will occur,
- thermal conditions under which the joint will be operated,
- environmental features, especially humidity and corrosive aggressiveness.

Adhesive joints perform well under dynamic loads, which follows primarily from the very good shock-absorbing properties of the layer of adhesive. Research works on the subject shows that the fatigue strength of adhesive joints may be estimated, on average, at the level of 30 – 40% of the immediate strength value.

Extremely important, sometimes of key significance, is the analysis of thermal conditions under which the joint will be operated. As a rule, adhesive bonds made with typical thermoplastic adhesives cannot be operated at temperatures higher than 60°C, as above that level their strength parameters drop rapidly. Adhesives based on certain synthetic resins, such as phenolic or silicone resins, suitably modified, can be operated at temperatures reaching the level of up to 300°C. Above that

temperature level ceramic adhesives are usually used, as bonds established with the help of such adhesives can be operated even at the temperature of 1500°C.

Adhesives joints of metals, not protected by means of suitable paint coating against the effect of moisture, are exposed to the desorptive effect of water molecules. In a hot and humid climate, the long-term strength of such bonds is considerably lower compared to the strength of bonds operated under the conditions of a dry climate.

7.3. Heuristic model for strength estimation of bonded metal-metal joints

The problems presented in preceding chapters, involved in the estimation of strength of adhesive bonds of metals demand that care must be taken in attempts at algorithmization of the process. The first and most important condition for undertaking such an attempt is the identification of factors affecting that strength. Identification of factors, understood not only formally as their cause-effect relation with strength, but also as a function of strength, permits duality of the structure of the estimation.

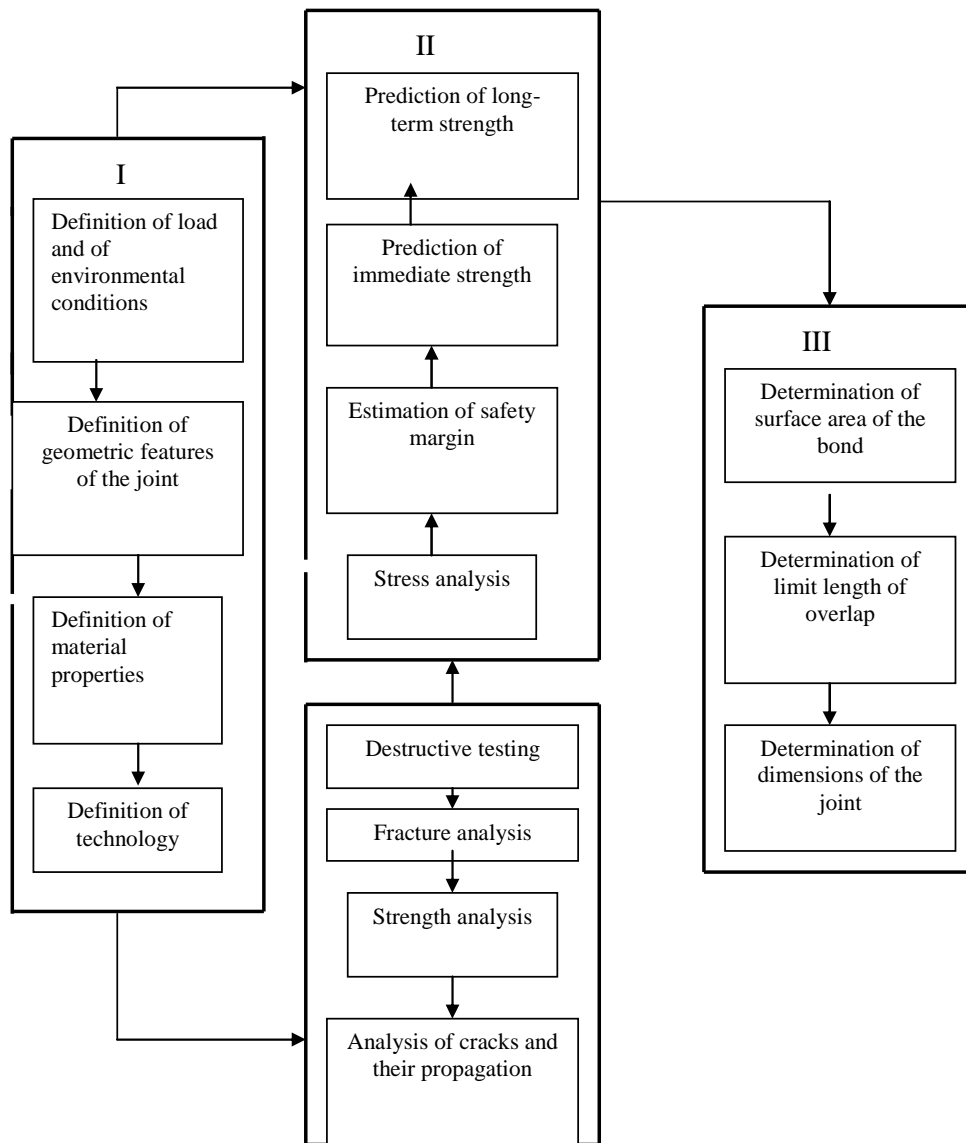

Fig. 7.1. Estimation of strength of adhesive joints of metals – general model [7.4, 7.5]

The problem can be approached in a comprehensive way and formulation of strength estimation can be attempted on the basis of the poly-optimisation procedure, or which sees safer, on the basis of fragmentary assessments resulting from process optimisation at several stages, especially at the stage of design and

process engineering with defined conditions of operation. A general model of the structure of the estimation process, modular in character and taking into account duality of the process of estimation, is presented in Fig. 7.1.

The model contains three basic modules: I - definition module, II – analytical-predictive module, III – testing module. The definition module comprises four blocks: definition of loads and environmental conditions, definition of geometric features of the joint, definition of the properties of materials, and definition of technology. Detailed structure of the particular blocks is presented in figures 7.2 – 7.5. Analysis of the joint on the basis of the structure of the definition block facilitates the estimation of strength and determination of factor of safety.

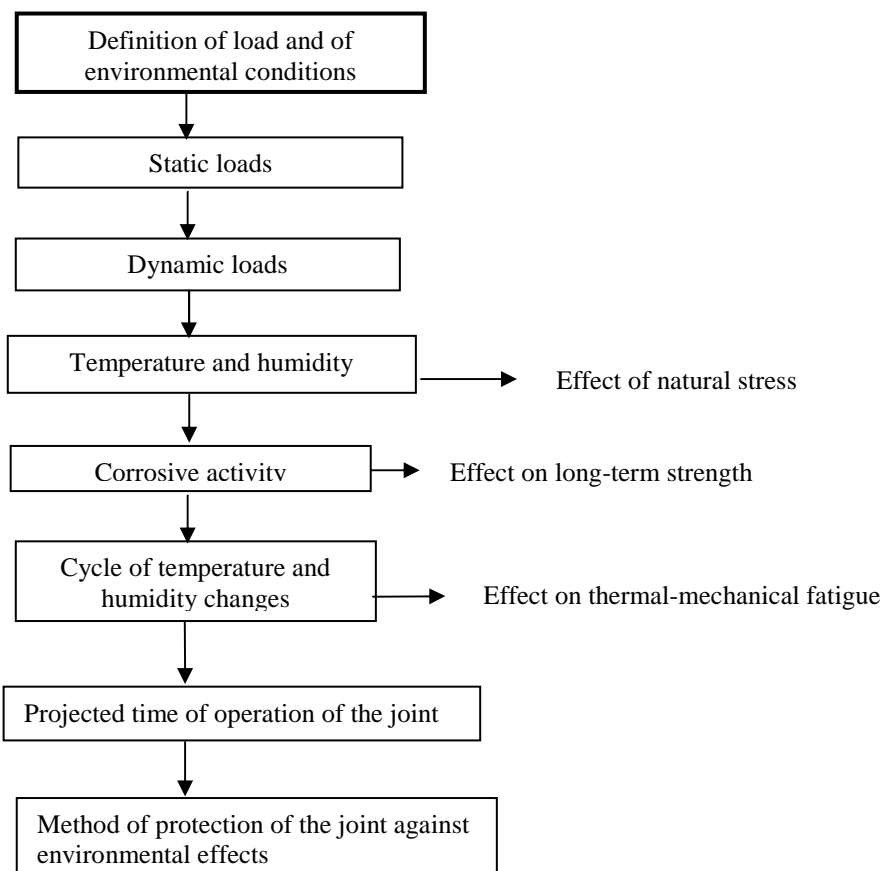

Fig. 7.2. Structure of the block covering the definition of loads and environmental conditions [7.4, 7.5]

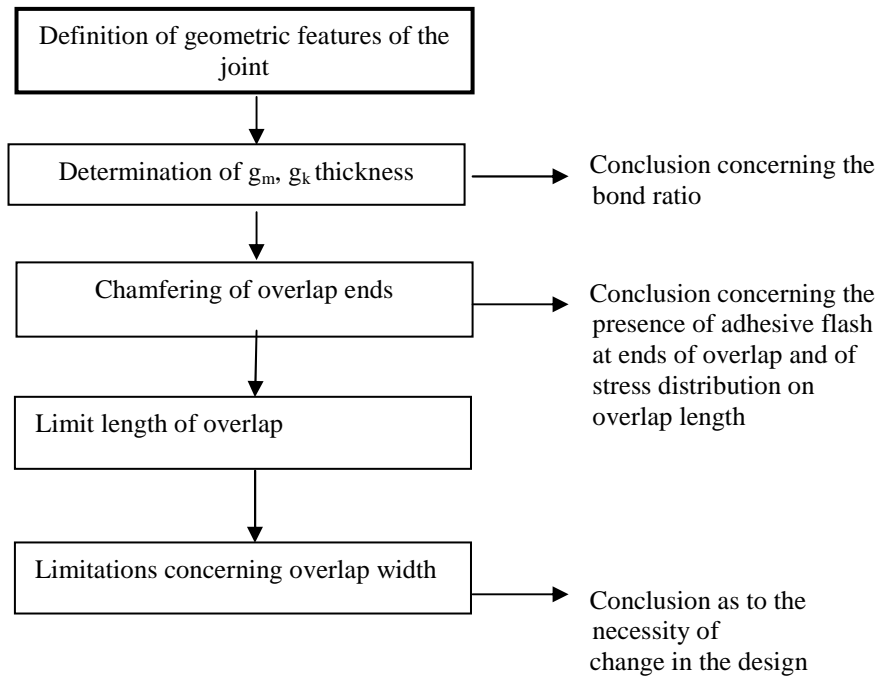

Fig. 7.3. Structure of the block covering the definition of the geometric features of the joint:
 g_m – thickness of bonded materials, g_k – thickness of layer of adhesive [7.4, 7.5]

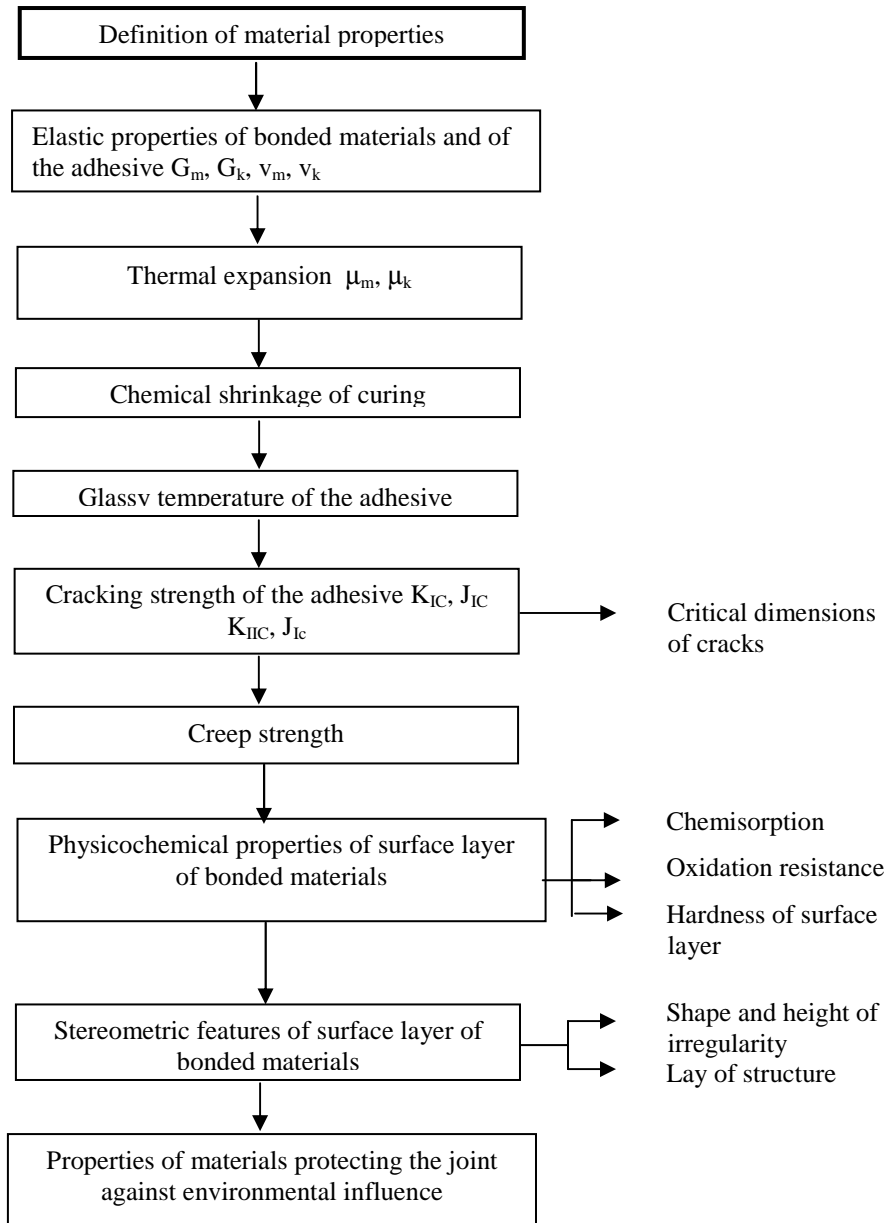

Fig. 7. 4. Structure of the block covering the definition of properties of materials: G – shear modulus, ν - Poisson coefficient, K – coefficients of stress intensity, J_{IC} – critical value of integral J, μ - coefficient of thermal expansion; index „m” refers to the materials bonded, index „k” to the adhesive [7.4, 7.5]

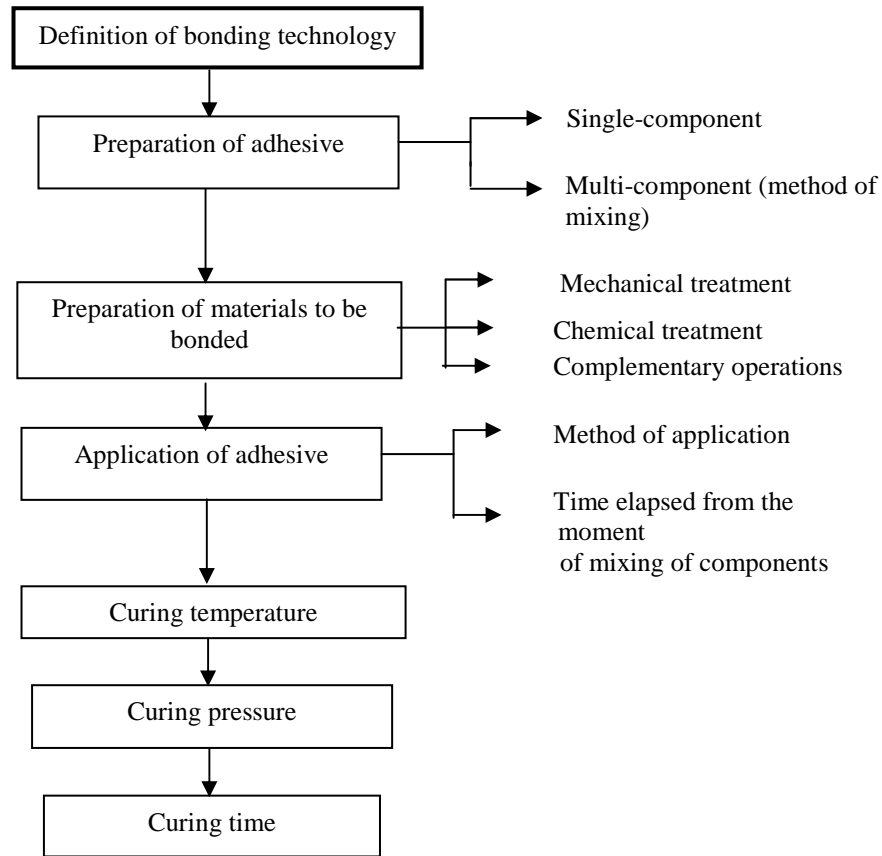

Fig. 7.5. Structure of the block covering the definition of bonding technology [7.4, 7.5]

After working through the module of definitions, there are two possible approaches to further prognostic work. The first is to skip the testing module and to proceed with the prognostic work on the analytical basis, and the second is to perform tests for the particular batches of adhesive. Especially important in such tests is the determination of the scatter of results (in the sense of mathematical statistics). Scatter of results is a measure of repeatability of material properties, technological discipline of the process of bonding, and the testing conditions. Important information, especially on the technology of surface preparation, can be obtained from fracture analysis. The best situation is when cohesive or adhesive-cohesive fractures are obtained – such fractures are usually accompanied by the least scatter of results. Application of adhesives with high values of E_k entails also the possibility of occurrence of violent cracks resulting from the existence of non-homogeneities of structure within the adhesive or cohesive zone. Studies of the cracking resistance of cured adhesives provide significant information on the

behaviour of adhesive coats, with the non-homogeneities existing in their structure, under the effect of external loads.

In prognostic work concerned with the long-term strength properties of adhesive bonds it is important to determine the creep characteristics of the bonds, which facilitates the prediction of permissible loads for the projected time of operation of the structure.

In practice it would be important to skip this stage and, making use of suitable mathematical models or correction coefficients resulting from analytical research, to conduct prognostic work on the basis on the definition module and the analytical-predictive module. Such work, however, is rendered difficult due to the fact that only some manufacturers provide the values of R_{mk} , E_k for adhesives in hardened state. Availability of such data would permit, on the basis of results of studies presented in [7.3, 7.4], to conduct design work and to predict the strength parameters for specific joints and specific conditions of operation.

In a situation when the values of R_{mk} , E_k are not known (e.g. for an adhesive prepared according to proprietary recipe) it is necessary to include the testing module. Estimation of those values on the basis of the chemical structure of the adhesive, though possible, may be burdened with considerable error. Very often the testing module can be limited to destructive tests only, to determine the values of breaking stress and the character of deformations. Fracture analysis plays in this case an auxiliary role, permitting for the formulation of conclusions on whether the bonding technology adopted, and especially the technology of surface preparation for bonding were appropriate.

7.4. Safety assessment of bonded structures

An adhesive joint, especially in structural bonding of metals, constitutes a system in which the strength of the structure is affected by many factors. In most general terms, those factors can be related to the technology, to design, and to operation. Frequently they interact mutually in a complex manner, which makes it convenient for the optimisation of the factor of safety to be conducted on the basis of statistical estimation. Such an analysis should be conducted every time on the basis of analysis of the scatter of strength parameters. This concerns both immediate strength and the prediction of changes in the factor of safety under conditions of long-term operation under load [7.1, 7.2, 7.3].

The adoption of correct factor of safety is an important moment in the work of a design engineer. Adoption of too high a factor of safety leads to „over-engineering” of structure, with all the negative consequences involved. Basing on the general assumptions one can accept that the function determining the factor of safety in lap-type adhesive joints can have the form:

$$n = f(x_s, x_{ce}, x_t, x_{wp}, x_p, x_g, x_n, x_{ob}, x_{sr}, x_w, x_{st}, x_{sz}, x_{uk}) \quad (7.1)$$

where: $x(\)$ – non-dimensional correction factors, including: x_s – correction factor for variability of micro-stereometric features of bonded surfaces, x_{ce} – correction factor for variability of chemical composition of surface layer and of energy properties of bonded surfaces, x_t – correction factor for variability of particular procedures in operations of adhesive bonding, x_{wp} – correction factor for variability of bonding coefficient, x_p – correction factor for variability of bonding surface area, x_g – correction factor for changes in the thickness of adhesive layer, x_n – correction factor for non-homogeneity of physical properties and structure of the adhesive, x_{ob} – correction coefficient for variability of loading conditions, x_{sr} – correction factor for environmental conditions and their variability, x_w – correction factor for the importance (level of responsibility) of the joint in the product, x_{st} – correction factor for non-homogeneity of materials constituting the joint, x_{sz} – correction factor for bending stiffness of elements joined, x_{uk} – correction factor for chamfering of overlap ends.

Determination of the detailed form of a function that would include the effect of all the factors enumerated above is extremely difficult. Prediction of the value of the factor of safety should have sub-optimal character. Let us consider that the factors included in the relation (7.1) can be categorized in two groups as follows:

- factors of random character,
- factors whose effects can be predicted and suitably quantified.

The effect of factors of random character is determined by the lowest permissible value of the factor of safety that can be determined statistically on the basis of analysis of scatter of strength. The probability of breaking the bond [7.6] can be expressed in the following way:

$$\alpha_1 = P(R < 0) = P[(\tau_n - \tau_o) < 0] = \int_{-\infty}^0 \varphi(x) dx \quad (7.2)$$

where: τ_n – stress breaking the bond, τ_o – stress applied, $\varphi(x)$ – probability density function.

For normal distribution (average strength of adhesive bonds is subject to distribution close to the normal) function $\varphi(x)$ has the form:

$$\varphi(x) = \frac{1}{(2\pi)^{0.5} D(R)} e^{-\frac{(x-\bar{R})^2}{2D^2(R)}} \quad (7.3)$$

where: \bar{R} , $D^2(R)$, $D(R)$ are the expected value, variance, and standard deviation, respectively, of the random variable R .

After standardization of the random variable R we obtain:

$$\alpha_i = P(R < 0) = \frac{1}{2} - \frac{1}{(2\pi^{0,5})} \int_0^{\frac{\bar{R}}{D(R)}} e^{-\frac{x^2}{2}} dx \quad (7.4)$$

Assuming that $\tau_o = \text{const}$, as a result $\bar{\tau}_o = \tau_o$ and $D^2(\tau_o) = 0$

The upper limit of integration in the equation (4) can be written as:

$$\frac{\bar{R}}{D(R)} = \frac{(\bar{n} - 1)\tau_o}{D(\tau_n)}$$

where:
$$\bar{n} = \mu\left(\frac{\tau_n}{\tau_o}\right) = \frac{\bar{\tau}_n}{\tau_o}$$

and: $\mu\left(\frac{\tau_n}{\tau_o}\right)$ means the expected value of the variable $\frac{\tau_n}{\tau_o}$

Assessment of probability of bond breaking can be presented as follows:

$$\alpha_i = P(R < 0) = \frac{1}{2} - \frac{1}{(2\pi^{0,5})} \int_0^{\frac{(\bar{n}-1)\tau_o}{D(\tau_n)}} e^{-\frac{x^2}{2}} dx \quad (7.5)$$

Adopting the coefficient of significance $\alpha = 0,05$ after reading from the table the distribution function of normal distribution $N(0,1)$ we obtain

$$\frac{(\bar{n} - 1)\tau_o}{D(\tau_n)} \tau_o = 1,64$$

$$\text{hence } \bar{n} = 1,64 \frac{D(\tau_n)}{\tau_o} + 1 \quad (7.6)$$

This is the sought expected value of the lowest value of factor of safety n defined as the ratio of τ_n/τ_o .

The bonding coefficient calculated in the way has a base value that should be corrected through the inclusion of the correction factors, enumerated in the relation (7.1), that do not have random character. With this assumption, the function determining the value of the factor of safety could be defined by the formula:

$$n = \left[1,64 \frac{D(\tau_n)}{\tau_o} + 1 \right] \frac{1}{x_{uk}} x_p x_{st} x_{sz} x_g x_w \quad (7.7)$$

where: x_{uk} , x_p , x_{st} , x_{sz} , x_g , x_w – coefficients of correlation as in equation (7.1)

In the relation defining the factor of safety, the breaking stress is defined as the shear stress τ_n . In reality those are compound stresses in which the contribution of breaking stress is often significant. In real situations, even though a lap joint is subjected to shear loading, the breaking of the joint is largely dependent on breaking stresses.

The values of the correction factors have been determined on the basis of own studies.

Values of correction factors determined experimentally for samples of steel and aluminium alloy are given in tables 7.1 – 7.5 [7.4]

Table 7.1. Values of correction factors x_{uk}

material \ g_m	0,5	2	3
Steel	1,25	1,1	1,05
Aluminium alloy	1,4	1,2	1,15

Table 7.2. Values of correction factor x_p

Lap joints		Heading joints	
S[cm] ²	x_p	S[cm] ²	x_p
1	1,3	1	1,4
2	1,15	2	1,2
2,5	1,1	2,5	1,1
3	1	3	1

Table 7.3. Values of correction factor x_{st}

Size of non-homogeneity	Steel		Aluminium alloy	
	$E_k < 2500 \text{MPa}$	$E_k > 2500 \text{MPa}$	$E_k < 2500 \text{MPa}$	$E_k > 2500 \text{MPa}$
<10% of bonding area	1,2	1,5	1	1,2
10 – 15% of bonding area	1,5	2	1,3	1,5

Table 7.4. Values of correction factor x_{sz}

material	$E_k < 2500 \text{Mpa}$		$E_k > 2500 \text{MPa}$		For all adhesives				
	g_m	<1,5	<2	<1,5	<2	1,5 - 2	2 – 2,2	>2	>2,5
Steel		1,2		1,15		1,1		1	
Al alloy			1,2		1,15		1,1		1

Table 7.5. Values of correction factor x_g

$g_k, \text{ mm}$	Lap joints		Heading joints	
	$E_k < 2500 \text{MPa}$	$E_k > 2500 \text{MPa}$	$E_k < 2500 \text{MPa}$	$E_k > 2500 \text{MPa}$
<0,15	1	1	1	1
<1	2	1,5	1,5	1,3
<3	3	2	2	1,5

The tables do not provide values of the correction factor x_w , as it should be determined every time for a specific structure and for specific conditions of operation. We can only indicate that for most structures $1 < x_w < 2$.

The value of the factor of safety determined in accordance with the relation (7.7) can be used for the estimation of immediate strength. For the estimation of the long-term strength, the relation should also include change in the scatter of strength parameters, as well as the decrease of strength in time, i.e. the term $\left(\frac{D(\tau_n)}{\tau_o}\right) = f(t)$.

It should also be emphasized that in design work the relation (7.7) can be used with the adoption of manufacturer's data on the values of breaking stress for particular adhesives. In such a case it is necessary to adopt a suitable value of standard deviation. The following recommendations should be followed when adopting the value of scatter:

- scatter of results tends to increase with increasing value of E_k ,
- scatter of results tends to increase with increasing value of g_k ,
- scatter of results tends to decrease with increasing value of R_{mk} ,
- scatter of results tends to decrease with increasing value of g_m .

This permits the estimation of all the values necessary at the stage of designing an adhesive joint.

The presented analysis, based primarily on the author's own experience and research, permits the formulation of the following main conclusions of general character:

1. The presented model of the structure of the process of designing and adhesive joints and predicting their strength properties includes all the most important design and technological factors whose identification is the condition for the design and predictive work to proceed correctly. It can also constitute a basis for the algorithmization of such work in the computer-aided approach.
2. Especially important is the estimation of the dynamics and character of changes in the strength of joints in time, i.e. their long-term strength characteristics. The main area of interest here is the method of protection of the joints against environmental effects, which determines the ageing-related changes in adhesives and the mechanisms of bond release at phase boundary.
3. Estimation of the factor of safety requires the assessment of the scatter of strength properties, i.e. factors whose effect on strength is random in character and dependent on a variety of influences. It is important for the factor of safety not to be adopted on an irrationally high level, leading to so-called "over-engineering" of the structure. In the process of estimation of the factor, irrespective of the factors presented in the analysed model, the importance of the joint in the structure and its degree of responsibility should also be considered.

7.5. Determination of bond dimensions

The result of the above analysis should the determination of the dimensions of the bond. In the case of lap joints the significant element is the length of overlap. Knowing the value of the factor of safety, we can determine the permissible stress

$\tau_0 = \frac{\tau_n}{n}$. Predicting the value of structure loading F we can determine the bond surface area S .

$$S = \frac{F}{\tau_0} = \frac{F}{\tau_n} n \rightarrow b = \frac{F}{\tau_n l_{gr}} n \quad (7.8)$$

If it turns out that for design reasons the width of overlap should be smaller, the following solutions are possible:

- application of a double-strapped joint (greater bond area),
- increase of thickness g_m (greater value of l_{gr}),
- application of a “stronger” adhesive (greater value of τ_n),
- increase of the dimensions of the structure (possibility of increasing overlap width).

In the case of the double-strapped joint it is also necessary to test the condition

$$g_m b k_r \geq S \tau_n \quad (7.9)$$

as it might happen that the bond will be broken in the cohesive zone of the bonded materials.

In the case of heading joints the problem is simpler, as we are not restricted by the length of the overlap and have greater freedom of modifying the dimensions of the bond area. It should be kept in mind, however, that in heading joints of small dimensions of bonding area the strength of the joint is strongly affected by boundary effects, which is manifest in greater scatter of results and thus also entails the necessity of applying a higher factor of safety.

References

- 7.1. Chlebus E.: Podstawy kształtowania funkcjonalnych cech i własności układów konstrukcyjnych obrabiarek. Prace Naukowe ITMiA Politechniki Wrocławskiej. Seria Monografie, nr 14, Wrocław, 1993.
- 7.2. Dietrych M. (red): Podstawy konstrukcji maszyn. Warszawa, 1995.
- 7.3. Domińczuk J.: Analiza wytrzymałości połączeń klejowych z wykorzystaniem sieci neuronowej. Rozprawa doktorska. Politechnika Lubelska, Wydział Mechaniczny, 2005.
- 7.4. Kuczmaszewski J.: Podstawy konstrukcyjne i technologiczne oceny wytrzymałości adhezyjnych połączeń metali. Wydawnictwo Politechniki Lubelskiej. Lublin, 1995.
- 7.5. Kuczmaszewski J.: Heurystyczny model oceny wytrzymałości klejowych połączeń metali. Przegląd Mechaniczny 1/2002.
- 7.6. Worobiej W.W., Sirotkin O.S.: Sojedinienija konstrukcji iz kompozicionnych materialow. Izd. „Maszinstrojenije”, Leningrad, 1985.

Chapter 8

Quality inspection and testing of bonded joints

8.1. Testing of adhesives

Pre-operation tests of adhesives can concern their mechanical, electric, thermal and processing properties, as well as viscosity, wetting ability, content of solids, density, pH, content of functional groups, content of free monomers, and other features, depending on the purpose for which a given adhesive is to be applied.

Viscosity is an important feature of liquid adhesives. It can be used as a basis for the determination of the technological usability of a given adhesive under specific conditions of bonding. There also exists a relation between viscosity and other physical properties of adhesives, which permits the prediction of such properties as uniformity of density, uniformity and stability of physical properties, characteristics of ageing processes, etc. There are many ways of determining viscosity. The Brookfield and Hoppler viscometers are relatively frequently used. Also used are the Ostwald, Ostwald-Pinkiewicz, Engler, Saybolt, and Redwood viscometers [7.13]. All the methods of measurement employ the Hagen-Poiseuille law (capillary flow of liquids), or else the Stokes law (settlement of spherical bodies in a liquid). Sometimes also other equipment is employed, such as flow-through vessels, and other indirect and comparative methods.

Usable life of adhesive composition is the time elapsing from the moment when the adhesive is ready for application to the moment when the adhesive ceases to wet bonded surfaces. Basically the value is adopted conventionally, with a certain tolerance or margin. Experimental tests for the determination of the usable time of adhesives are based on measurement of viscosity or on shear tests.

Loss in weight is determined experimentally as the ratio of sample weight before curing to the sample weight after curing, usually expressed as a percentage value. In practice it consists in accurate weighing of a small amount of adhesive, followed by its thorough curing and repeated weighing when cured; then the index of loss in weight is calculated as follows:

$$a = \frac{A - B}{A} 100\% \quad (8.1)$$

where: a – index of loss of weight, A – initial weight of sample, B – weight of sample after curing.

Wetting ability is a very important property of adhesives that – to a large extent – determines the value of adhesion. It is relatively difficult to determine and, as a rule, is used only for purposes of comparing the wetting ability of various adhesives. Most often used in comparative tests is the measurement of the wetting

angle. It is not an accurate method, as the wetting angle depends not only on the wetting ability of the adhesive, but also on the adhesive properties of the surface. The mutual interactions may interfere with the interpretation of the adhesive properties of the adhesive.

Rate of curing (setting) – testing of this characteristic of adhesives usually consists in determination of changes in strength with relation to conditions of curing. Samples are prepared from the same adhesive, then the changes in the physical state of the adhesive are monitored in time, for example through measurements of strength or hardness.

Apart from the above tests for qualification of adhesives prior to bonding operations many other technological tests are used as recommended by industry standards or by standards imposed by licence agreements.

8.2. Testing of adhesive properties of surface layer of bonded elements

Adhesive properties of surface layer comprise all the properties that define the applicability of a given material for various operations in which adhesion plays the leading role.

In recent years in studies on adhesive properties a tendency is observed to adopt the energy approach as the most relevant to the essence of such processes. For exhaustive determination of the adhesive properties of the surface layer of a material it is necessary to determine its free surface energy. The value of free surface energy can be used as a measure for the estimation of the preparation of the surface layer for processes of e.g. adhesive bonding, sealing, printing.

In view of the lack of direct methods for the determination of free surface energy of materials in solid state, indirect methods are employed. Examples of indirect methods for the determination of free surface energy include the methods of van Oss–Good, Owens–Wendt, and others [8.8, 8.9, 8.14, 8.20, 8.33]. Those methods are most frequently based on measurement of wetting angle of measuring liquids.

The wetting angle can be determined through direct measurement or indirectly, through measurement of certain geometric dimensions of a drop. An auxiliary drawing for such calculations is presented in Fig. 8.1.

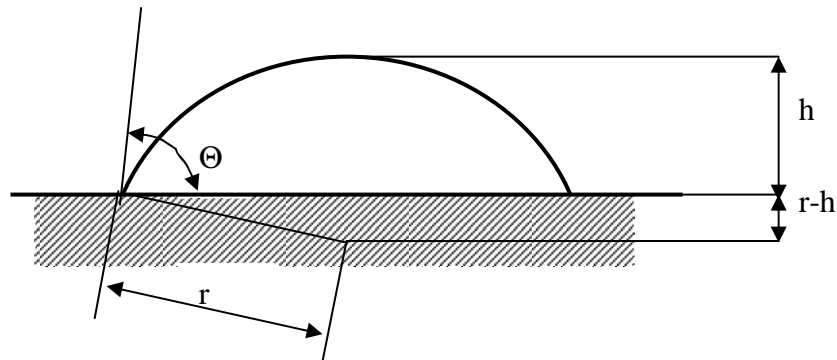

Fig. 8.1. Schematic drawing for the calculation of wetting angle from the geometric dimensions of a drop

The wetting angle Θ , on the basis of fig. 8.1, can be calculated from the relation:

$$\cos \Theta = \frac{r}{r-h} \quad (8.2)$$

It should be noted, however, that the indirect method, the idea of which is presented in Fig. 8.1, adopts the postulate that the shape of the drop corresponds to that of a segment of a sphere. That postulate is true only for a certain volume of the drop.

For comparative studies it is also possible to use the work of adhesion W_a . It is the value of free energy required to separate two phases at constant pressure and temperature. Although this does not provide full determination of adhesive properties, but can be used as a comparative measure due to its relatively simple and easy method of determination. Most frequently the measuring fluid used is distilled water, with known value of free surface energy [8.9, 8.14, 8.33].

Knowledge of the stereometric structure of surface [8.1, 8.3, 8.10] plays a significant role, especially in the theory of mechanical adhesion. It is also a source of information used in preliminary energy analysis of the surface under examination. It is possible to make a preliminary assessment of the ratio of active surface area (wetting) to the actual surface area. Increase in the actual surface area within the geometric surface multiplies the effect of intermolecular forces, among other effects. However, excessive content of narrow micro-pores is usually unfavourable, as an adhesive with high viscosity and a high value of free surface energy cannot fill such pores. In such a case there may appear a layer weakening the adhesive bond, formed of gas bubbles trapped in the pores.

Surface roughness is also a highly significant element [8.25, 8.26, 8.29, 8.30, 8.31, 8.32] in the aspect of the theory of mechanical adhesion. Considerable

increase in the share of mechanical adhesion in total adhesion can be achieved through suitable machining of the surface.

The literature of the subject provides the recommended values of various parameters of surface roughness of materials from the viewpoint of the technology of adhesive bonding [8.4, 8.24, 8.31, 8.32]. On the basis of knowledge of certain parameters of surface roughness it is possible to formulate conclusions concerning the suitability of surfaces for adhesive bonding. It is also possible to formulate certain recommendations concerning the method of preparation of the surface layer of materials.

There are many methods for the determination of free surface energy γ_s [8.8, 8.9, 8.14, 8.20, 8.31, 8.33]. The Owens–Wendt method gained the greatest importance due to its numerous advantages, though it also raises certain reservations, for a variety of reasons. In the method it is assumed that free surface energy is sum of two components: dispersive (γ_s^d) and polar (γ_s^p).

In the determination of free surface energy two measuring liquids are used. Often these are distilled water and diiodomethane. Distilled water is a strongly polar liquid, as its polar component is 51 mJ/m² with a total free surface energy value of 72.8 mJ/m². Diiodomethane - CH₂I₂ – is an almost totally apolar liquid. The polar component of diiodomethane is 2.3 mJ/m², with total free surface energy value of 50.8 mJ/m². For the measurement of the wetting angle the method employed is that of direct of measurement of the wetting angle formed by a drop of the measuring liquid with the surface tested.

In the Owens–Wendt method [8.14], after suitable transformations the following relations are obtained:

$$\left(\gamma_s^d\right)^{0.5} = \frac{\gamma_d(\cos \Theta_d + 1) - \sqrt{\frac{\gamma_d}{\gamma_w}} \gamma_w(\cos \Theta_w + 1)}{2\left(\sqrt{\gamma_d^d} - \sqrt{\gamma_d^p \frac{\gamma_w^d}{\gamma_w^p}}\right)} \quad 8.3$$

$$\left(\gamma_s^p\right)^{0.5} = \frac{\gamma_w(\cos \Theta_w + 1) - 2\sqrt{\gamma_s^d \gamma_w^d}}{2\sqrt{\gamma_w^p}} \quad 8.4$$

where: γ_s^d – dispersive component of free surface energy of tested materials, γ_s^p – polar component of free surface energy of tested materials, γ_d – free surface energy of diiodomethane, γ_d^d – dispersive component of free surface energy of diiodomethane, γ_d^p – polar component of free surface energy of diiodomethane, γ_w – free surface energy of water, γ_w^d – dispersive component of free surface energy of water, γ_w^p – polar component of free surface energy, θ_d – angle of wetting with diiodomethane, θ_w – angle of wetting with water

Performing the measurement of the angle of wetting with water and diiodomethane one can calculate the dispersive and polar components and then sum them up – the components are additive.

8.3. Non-destructive testing of bonded joints

Non-destructive tests [8.15] of bonded joints are, by assumption, to provide information on the condition of the joint, with the process of testing itself not causing any changes in the properties tested.

In non-destructive testing of adhesive bonds the methods used the most frequently include the following:

- acoustic methods,
- radiological methods,
- electromagnetic methods,
- thermal methods,
- optical methods,
- penetration methods.

A typical method of non-destructive testing is the ultrasonic method. For lap joints straight or fixed ultrasonic probe heads can be used, for heading joints – angled or indexing heads (Fig. 8.2).

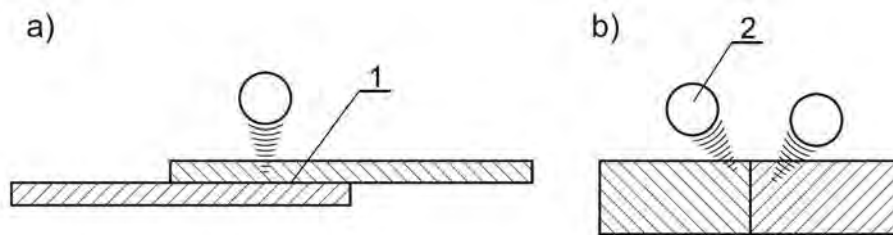

Fig. 8.2. Lap-type adhesive joint testing with straight probe head (a), and testing of heading joints with angled (or indexing) probe heads (b); 1 – bond area, 2 – probe head

At present, available on the market are small, portable defectoscopes with digital displays, for adhesive bond testing often equipped with automatic scanning systems.

The X-ray technique has been used in radiographic testing for a long time. Modern version of X-ray defectoscopes operate automatically and permit 3D visualisation of discontinuity of structure. They are also available in portable versions.

Flaw detection [8.15] testing can also be realized by means of portable magnetic detectors, but the greatest testing potential is still provided by stationary defectoscopes of high power.

Aerosol dye penetrants are used primarily for the detection of surface flaws and defects, but they can also be used for testing adhesive bonds, especially in the aspect of leak tightness.

Optical methods are primarily endoscopic methods which currently are going through a period of violent development.

For the detection of discontinuity of bonding also thermographic methods can be used. The application of thermal detection and imaging is especially interesting with relation to the detection of unbonded spots and gas bubbles.

A schematic diagram of an ultrasonic defectoscope is presented in Fig. 8.3

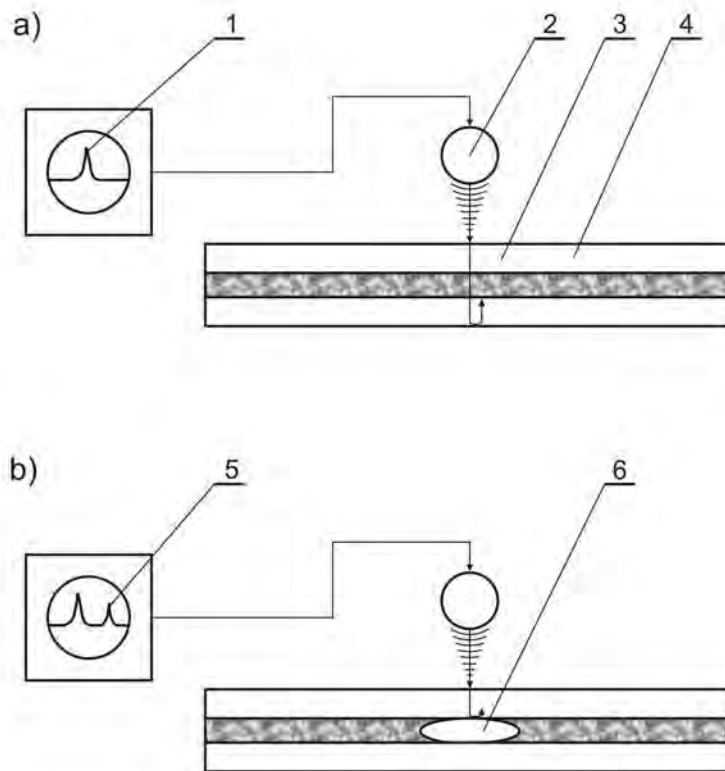

Fig. 8.3. Schematic of the operation of ultrasonic defectoscope (reflectoscope): a) in the case of adhesive bonding of materials strongly absorbing ultrasonic waves the reflected signal returns greatly weakened, b) in the case of unbonded spots the signal gets reflected by the material-gap boundary, 1 – initial signal, 2 – emitter-receiver probe, 3 – bonded material, 4 – layer of adhesive, 5 – signal reflected from unbonded spot, 6 – unbonded spot

All of the enumerated methods have the objective of localizing and determining the area of unbonded spots and other flaws, especially intrusions and

gas bubbles. The ultra-acoustic flaw detector [8.15] permits the detection of unbonded spots in sandwich structures, unbonded spots at the boundary between adhesive and bonded material, increased porosity (thin spots), delaminated areas in plastics.

The X-ray technique permits rapid assessment of the quality of bonding, but it requires more experienced personnel as it is more difficult in terms of interpretation of results, especially with relation to sandwich structures. A schematic of the principle of operation of X-ray flaw detection is presented in Fig. 8.4.

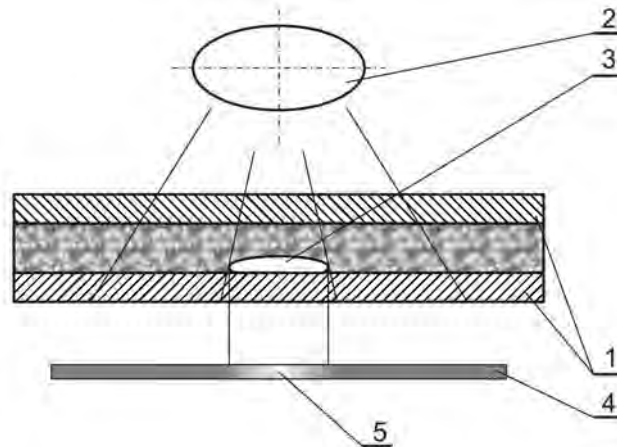

Fig. 8.4. Principle of operation of X-ray flaw detector: 1 – upper and lower layers of bonded materials, 2 – X-ray unit, 3 – unbonded spot, 4 – photographic plate (film), 5 – image of the gap

More and more often thermography is employed for flaw detection. An adhesive joint is illuminated from one side with an IR lamp and the image is recorded by a thermal imaging camera. The presence of a flaw (unbonded spot, gas bubble) changes the heat transfer image. Such a system is presented schematically in Fig. 8.5.

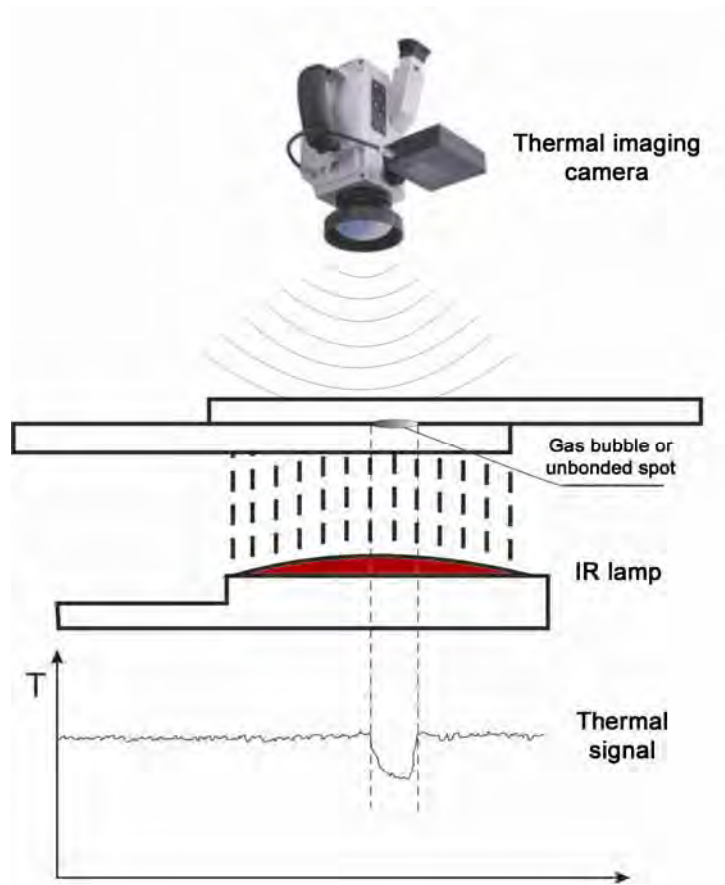

Fig. 8.5. Schematic diagram of thermographic flaw detector

A relatively new method for the detection of unbonded spots is based on the use of liquid crystals. The method makes use of properties of cholesterol compounds, consisting in colour change under the effect temperature change. Within the area of an unbonded spot there is a change in the thermal conductivity of the bonded elements, which makes unbonded spots to become visible during heating of the bonded assembly.

Moreover, stress analysis is employed in testing adhesive joints. The more important methods are the following:

Stress testing:

- extensometric method,
- brittle coats method,
- photo-elasticity method,
- holographic interferometry,

- spot method (interference of waves scattered by an actual surface; illumination with a light beam gives the effect of spotting)

Non-destructive testing:

- visual methods,
- penetration methods,
- magnetic methods,
- eddy current methods,
- ultrasonic methods,
- radiation methods.

It should be added that more and more advanced methods of model analysis with the use of finite elements method and extensive databases of results from material testing cause that stress analysis with the method of finite elements is more and more commonly used and it becomes more and more credible.

8.4. Destructive testing of bonded joints

Destructive testing is necessary to verify even highly advanced methods of strength prediction [8.2, 8.4, 8.12, 8.19, 8.24, 8.32]. Very often, especially with new batches of adhesives, so-called “companion samples” are made. Such tests most frequently consist in the determination of immediate shear, break, peel, or bending strength.

Increasingly common use of adhesive bonding in machine assembly causes that new standards are developed to cover the new areas of application. A list of the more important standards is given in table 8.1.

Table. 8.1. More important standard applicable to adhesive bonding of metals

Item	Standard No.	Title of standard
1	2	3
1	PN-69/C-89300	Adhesives for metal bonding. Determination of shear strength
2	PN-59/C-89301	Adhesives for metal bonding. Determination of breaking strength
3	PN-69/C-89302	Adhesives for metal bonding. Determination of peel strength
4	PN-69/C-89304	Adhesives for metal bonding. Determination of bending strength
5	PN-EN 2243-1:1999	Aircraft and spacecraft. Structural adhesives. Testing methods. Determination of shear strength of metal-metal adhesive bond.
6	PN-EN 2243-2:1999	Aircraft and spacecraft. Structural adhesives. Testing methods. Determination of peel strength of metal-metal adhesive bond.

1	2	3
7	PN-EN 2243-3:1999	Aircraft and spacecraft. Structural adhesives. Testing methods. Determination of peel strength of metal-cellular core adhesive bond.
8	PN-EN 1464:2000	Adhesives. Determination of peel strength of high-strength adhesive bonds. Floating roller method.
9	PN-EN 14173:2004	Adhesives for structural joints. Determination of peel strength, with T-method, of adhesive bond of two flexible materials.
10	PN-EN 26922:2000	Adhesives. Determination of tensile strength of heading joints.
11	PN-EN 26922:2000	Adhesives. Determination of peel strength of joint of flexible and rigid elements. Peel at 90 degrees.
12	PN-EN 26922:2000	Adhesives. Determination of peel strength of joint of flexible and rigid elements. Peel at 180 degrees.
13	PN-EN ISO 9664:2000	Adhesives. Methods for testing fatigue properties of adhesives for structural joints under shearing tension.
14	PN-EN ISO 10363:1999	High-melt adhesives. Determination of thermal stability.
15	PN-EN ISO 10365:1998	Adhesives. Determination of primary standards of breaking of adhesive bonds.
16	PN-EN ISO 10964:2000	Adhesives. Determination of unscrewing strength of threaded joints protected with anaerobic adhesives
17	PN-ISO 4588:1999	Adhesives. Guidelines for surface preparation – metals
18	PN-ISO 9653:2000	Adhesives. Method for testing the impact shear strength of adhesive bonds
19	PN-ISO 10354:2001	Adhesives. Strength characteristics of assemblies joined with structural adhesives. Wedge test.
20	PN-ISO 10364:1999	Adhesives. Determination of usable life of multi-component adhesives.
21	PN-ISO 15108:2002	Adhesives. Determination of bending-shear strength of adhesive bonds.
22	PN-ISO 15109:2002	Adhesives. Determination of time to breaking of adhesive bonds under static load.
23	PN-68/C-02004	Adhesives. Principles of classification.
24	PN-EN 1066:1999	Adhesives. Sampling.

1	2	3
25	PN-EN 1067:1999	Adhesives. Initial assessment and preparation of samples for testing.
26	PN-EN 12092:2004	Adhesives. Determination of viscosity.
27	PN-EN 1238:2001	Adhesives. Determination of softening point of thermoplastic adhesives (ring and sphere method).
28	PN-EN 1239:2000	Adhesives. Determination of frost resistance.
29	PN-EN 1240:2001	Adhesives. Determination of hydroxyl number and/or content of hydroxyl groups.
30	PN-EN 1241:2001	Adhesives. Determination of acid number.
31	PN-EN 1242:2001	Adhesives. Determination of content of isocyanate groups.
32	PN-EN 1244:2000	Adhesives. Determination of colour and/or colour change of adhesive coats under the effect of light.
33	PN-EN 1245:2001	Adhesives. Determination of pH. Method of testing.
34	PN-EN 12963:2002	Adhesives. Determination of content of free monomers in adhesives based on synthetic polymers.
35	PN-EN 14022:2005	Adhesives for structural joints. Determination of usable life of multi-component adhesives.
36	PN-EN 14258:2005	Adhesives for structural joints. Mechanical properties of adhesive bonds subjected to short- and long-term effect of specific temperature conditions.
37	PN-EN 14493:2004	Adhesives for structural joints. Determination of dynamic splitting strength of high-strength adhesive bonds under the effect of impact conditions. Wedge impact method.
38	PN-EN 1465:2003	Adhesives. Determination of shear strength in tensile test of lap joints of two rigid materials.
39	PN-EN 14869-1:2005	Adhesives for structural joints. Determination of shear strength of structural adhesive joints. Part 1: Torsion test with two hollow cylinders in heading joint.
40	PN-EN 14869-2:2005	Adhesives for structural joints. Determination of shear strength of structural adhesive joints. Part 2: Shear test with thick bonded elements.

1	2	3
41	PN-EN 1966:2004	Adhesives for structural joints. Determination of surface characteristics through adhesion measurement with the three-points bending method.
42	PN-EN 1967:2004	Adhesives for structural joints. Estimation of effectiveness of aluminium surface machining techniques through wet peel testing in combination with the floating roller method.
43	PN-EN 29142:1999	Adhesives. Guidelines for the selection of standardized conditions of laboratory ageing for adhesive bond testing.
44	PN-EN 828:2000	Adhesives. Determination of wetting ability through measurement of wetting angle and critical surface tension of solids.
45	PN-EN 924:2005	Adhesives. Solvent and non-solvent adhesives. Determination of ignition temperature (flash-point).
46	PN-ISO 15109:2002	Adhesives. Determination of time to breaking of adhesive bonds under static loading.

Testing of fatigue strength of adhesive joints is becoming more and more important, and so do problems related to the ageing of adhesive bonds. Application of standards developed for metals in fatigue tests of polymer materials (in a great majority of cases adhesives are polymer materials) may sometimes lead to erroneous conclusions. In some cases, at frequencies of the order of 50Hz, typical for fatigue testing of metals, in fatigue testing of polymers there appears the phenomenon of self-induced temperature. Experiments have shown that it is the best to conduct fatigue testing of adhesive bonds of metals at frequencies of 10–30 Hz. For purposes of comparisons the parameters adopted in standards DIN 54452 and ASTM D 3166-73 are used. Currently fatigue testing of adhesive joints can be conducted in accordance with the standard PN-EN ISO 9664:2000.

References

- 8.1. Adamczyk S.: Odniesieniowe metody pomiaru zarysów okrągłości części maszyn. Politechnika Świętokrzyska. Kielce, 1998.
- 8.2. Brojer Z., Hertz Z., Penczek P.: Żywice epoksydowe. WNT, Warszawa, 1998.
- 8.3. Burakowski T.: Inżynieria powierzchni metali. WNT, Warszawa, 1992.
- 8.4. Cagle Ch.V.: Kleje i klejenie. WNT, Warszawa, 1997.
- 8.5. Cempel Cz.: Wibroakustyka stosowana. PWN, Warszawa, 1989.
- 8.6. Dieriagin B. W., Krotowa N. A.: Adgieszja. Izd. AN SSSR, 1949.
- 8.7. Dutkiewicz E.T.: Fizykochemia powierzchni. WNT, 1998.

- 8.8. Fowkes F. M.: Ind. Eng. Chem. 1964 nr. 12 .
- 8.9. Fowkes F.M.: J. Coll. Interf. Sci, 1968, vol 28, N3.
- 8.10. Górecka R., Polański Z.: Metrologia warstwy wierzchniej. WNT, Warszawa, 1983.
- 8.11. Groszkowski J.: Technika wysokiej próżni. PWN, Warszawa, 1979.
- 8.12. Hamrol A., Mantura W.: Zarządzanie jakością. Teoria i praktyka. Wydawnictwo Naukowe PWN, Warszawa, 1998.
- 8.13. Hebda M., Wahal A.: Trybologia. WNT Warszawa, 1980.
- 8.14. Jańczak B.: Adhezja wody do powierzchni polimerów. Polimery nr. 13, 1989.
- 8.15. Jóska M.: Metodologiczne aspekty oceny przyczepności powłok regeneracyjnych metodą ultradźwiękową. Wydawnictwo Politechniki Poznańskiej. Poznań, 2002.
- 8.16. Kalinowski L.: Fizyka metali. PWN, Warszawa, 1973.
- 8.17. Kittel C.: Wstęp do fizyki ciała stałego. PWN, Warszawa, 1976.
- 8.18. Kuczmaszewski J.: Technologia śmigłowców. Wydawnictwa Uczelniane. Politechnika Lubelska, 1990.
- 8.19. Kuczmaszewski J.: Podstawy konstrukcyjne i technologiczne oceny wytrzymałości adhezyjnych połączeń metali. Wydawnictwa Uczelniane. Politechnika Lubelska, 1995.
- 8.20. Kuczmaszewski J: Some methodological problems in assessing the adhesive properties of surface layer of plastics. Int. Pol. Sc. And Techn. Vol. 29, N5, 2002.
- 8.21. Kellar K.: Chemia polimerów. Wydawnictwo Politechniki Poznańskiej. Poznań, 1991.
- 8.22. Kotnarowska D.: Prognozowanie trwałości powłok ochronnych. Zagadnienia eksploatacji maszyn, 1992, vol 27,1.
- 8.23. McBain J.W., Hopkins G.: J. Phys. Chem, 1925, vol. 29, N3.
- 8.24. N.A. de Bruyne, Houwink R.: Klebtechnik. Berliner Union, Stuttgart, 1957.
- 8.25. Nowicki B.: Chropowatość i falistość powierzchni. WNT, Warszawa, 1995.
- 8.26. Oczko K., Lubimow V.: Struktura geometryczna powierzchni. Oficyna Wydawnicza Politechniki Rzeszowskiej, Rzeszów, 2003.
- 8.27. Piaseczny L.: Technologia polimerów w remontach okrętów. Gdańskie Towarzystwo Naukowe. Gdańsk, 2002.
- 8.28. Ratajczyk E.: Współrzędnościowa technika pomiarowa. Maszyny i roboty pomiarowe. Oficyna Wydawnicza Politechniki Warszawskiej. Warszawa, 1994.
- 8.29. Shornhorn H., Sharpe H.: Polymer Lett., 1964, vol. 2, N7.
- 8.30. Sikora R.: „Tworzywa wielkocząsteczkowe. Rodzaje, właściwości i struktura”. Wydawnictwo Uczelniane, Lublin, 1991.
- 8.31. Wakuła W. Ł., Pritikin Ł., M.: Fizyczna chemia adhezji polimerów. Moskwa, Chimija, 1984.
- 8.32. Vojucki S.S.: Wysokomolekularnyje sojedinenija, 1959, T1, N2.
- 8.33. Żenkiewicz M.: Adhezja i modyfikowanie warstwy wierzchniej tworzyw wielkocząsteczkowych. WNT, Warszawa, 2000.

Chapter 9

Conclusion

Adhesive bonding is employed more and more frequently in the machine building industry, in aerospace industry, building industry, home appliance industry, power industry, electronics industry, and automotive industry. It is becoming more and more important to provide the design engineers in all those industries with information necessary for the design of adhesive joints. Metal bonding is the dominant application of adhesives in the products of those industries, hence that area of adhesive bonding application is of particular importance. The complexity of the problems of prediction of the strength of adhesive joints, especially under conditions of long-term operation in variable environmental conditions, implies the necessity of heuristic approach to design. The importance of practical observations and conclusions also increases, especially of those from multi-year experiments on the ageing of adhesive joints, and of the frequently surprising conclusions following from energy activation of surfaces. Such conclusions permit practical application of that experience, especially with relation to structures that do not perform too critical functions.

Cooperation between specialists in the chemical technology of adhesive materials and specialists in various branches of engineering and technology resulted in an interesting array of possibilities. It is now possible to order adhesives with “customized” properties and characteristics. Several trends are worthy of mention in this respect:

- with respect to chemically cured adhesives there is a tendency to provide a possibly broad range of curing times, from very short to relatively long, where it is important, for technological reasons, to extend the period of applicability of the adhesive;
- in the case of solvent adhesives, an increasingly important role is played by adhesives for which water is the thinner, which is of particular significance for ecological reasons;
- there is an on-going intensive research effort on industrial versions of electro-conducting adhesives, which is of special importance for the electronics industry;
- resistance to environmental effects is an important feature of adhesives, hence the search for various, economically justifiable, methods of modification of adhesives;
- increasingly common utilisation of adhesives in various branches of engineering and technology causes that more and more types and brands of adhesives become available in confectioned forms and packaging, including so-called “adhesive dots”.

The rapid development of the chemistry of adhesives, observed in recent years, is based on predictions of more and more common application of adhesives in various branches of technology.